



**Australian Government**  
**Australian Digital Health Agency**



## **Pathology Report with Structured Clinical Content CDA Implementation Guide**

26 April 2022 v1.0

Approved for external use

Document ID: DH-3532:2022



### Acknowledgements

The Australian Digital Health Agency is jointly funded by the Australian Government and all state and territory governments.

### Regenstrief Institute (LOINC)

This material contains content from [LOINC](#)<sup>TM</sup>. The LOINC table, LOINC codes, LOINC panels and forms file, and LOINC linguistic variants file are copyright © 2022 Regenstrief Institute, Inc. and the Logical Observation Identifiers Names and Codes (LOINC) Committee and available at no cost under the license at the [LOINC Terms of Use](#). LOINC is a trademark of Regenstrief Institute, Inc., registered in the United States.

### IHTSDO (SNOMED CT)

This material includes SNOMED Clinical Terms<sup>TM</sup> (SNOMED CT<sup>®</sup>) which is used by permission of the International Health Terminology Standards Development Organisation (IHTSDO). All rights reserved. SNOMED CT<sup>®</sup> was originally created by The College of American Pathologists. “SNOMED” and “SNOMED CT” are registered trademarks of the [IHTSDO](#).

### HL7 International

This document includes excerpts of HL7<sup>TM</sup> International standards and other HL7 International material. HL7 International is the publisher and holder of copyright in the excerpts. The publication, reproduction and use of such excerpts is governed by the [HL7 IP Policy](#) and the HL7 International License Agreement. HL7 and CDA are trademarks of Health Level Seven International and are registered with the United States Patent and Trademark Office.

---

### Disclaimer

The Australian Digital Health Agency (“the Agency”) makes the information and other material (“Information”) in this document available in good faith but without any representation or warranty as to its accuracy or completeness. The Agency cannot accept any responsibility for the consequences of any use of the Information. As the Information is of a general nature only, it is up to any person using or relying on the Information to ensure that it is accurate, complete and suitable for the circumstances of its use.

### Document control

This document is maintained in electronic form and is uncontrolled in printed form. It is the responsibility of the user to verify that this copy is the latest revision.

### Copyright © 2022 Australian Digital Health Agency

This document contains information which is protected by copyright. All Rights Reserved. No part of this work may be reproduced or used in any form or by any means – graphic, electronic, or mechanical, including photocopying, recording, taping, or information storage and retrieval systems – without the permission of the Australian Digital Health Agency. All copies of this document must include the copyright and other information contained on this page.

OFFICIAL

## Document information

### Key information

**Owner** Director, Connectivity & Informatics

**Contact for enquiries** Australian Digital Health Agency Help Centre

Phone [1300 901 001](tel:1300901001)

Email [help@digitalhealth.gov.au](mailto:help@digitalhealth.gov.au)

### Product or document version history

---

Product or document version	Date	Release comments
V1.0	22/04/2022	Pathology Report with Structured Clinical Content CDA Implementation Guide v1.0 marked as a draft has been approved for implementation. Please ignore the watermark and Header.

---



**Pathology Report with Structured Clinical Content  
CDA Implementation Guide  
Version 1.0**

25 February 2016

Draft Version 011

Draft for restricted external review

Document ID: NEHTA-2117:2016

**THIS SPECIFICATION HAS NOT YET RECEIVED FORMAL  
SIGN-OFF FROM NEHTA AND SHOULD NOT BE USED FOR  
IMPLEMENTATION.**

---

**National E-Health Transition Authority Ltd**

Level 25  
56 Pitt Street  
Sydney NSW 2000  
Australia  
[www.nehta.gov.au](http://www.nehta.gov.au)

DRAFT

**Disclaimer**

The National E-Health Transition Authority Ltd (NEHTA) makes the information and other material ('Information') in this document available in good faith but without any representation or warranty as to its accuracy or completeness. NEHTA cannot accept any responsibility for the consequences of any use of the Information. As the Information is of a general nature only, it is up to any person using or relying on the Information to ensure that it is accurate, complete and suitable for the circumstances of its use.

**Document Control**

This document is maintained in electronic form and is uncontrolled in printed form. It is the responsibility of the user to verify that this copy is the latest revision.

**Copyright © 2015 National E-Health Transition Authority Ltd**

This document contains information which is protected by copyright. All Rights Reserved. No part of this work may be reproduced or used in any form or by any means—graphic, electronic, or mechanical, including photocopying, recording, taping, or information storage and retrieval systems—without the permission of NEHTA. All copies of this document must include the copyright and other information contained on this page.

# Document Information

## Key Information

<b>Owner</b>	Head of Delivery
<b>Contact for enquiries</b>	NEHTA Help Centre
	t: 1300 901 001
	e: <a href="mailto:help@nehta.gov.au">help@nehta.gov.au</a>

## Product Version History

<b>Product Date version</b>	<b>Release comments</b>
1.0 25 Feb 2016	Initial release for feedback.

## Related Documents

<b>Name</b>	<b>Version/Release Date</b>
<a href="#">Pathology Report with Structured Clinical Content Structured Content Specification</a>	Version 1.0, To be published
<a href="#">Participation Data Specification</a>	Version 3.2, Issued 20 July 2011
<a href="#">Pathology Report with Structured Clinical Content Information Requirements</a>	Version 1.0, To be published
<a href="#">Clinical Documents Common Conformance Profile</a>	Version 1.6, Issued 10 April 2015
<a href="#">CDA Rendering Specification</a>	Version 1.0, Issued 07 March 2012

DRAFT

# Acknowledgements

## Council of Australian Governments

The National E-Health Transition Authority is jointly funded by the Australian Government and all State and Territory Governments.

## Regenstrief Institute (LOINC)

This material contains content from LOINC™ (<http://loinc.org>). The LOINC table, LOINC codes, LOINC panels and forms file, and LOINC linguistic variants file are copyright © 1995-2015, Regenstrief Institute, Inc. and the Logical Observation Identifiers Names and Codes (LOINC) Committee and available at no cost under the license at <https://loinc.org/terms-of-use/>. LOINC is a trademark of Regenstrief Institute, Inc., registered in the United States.

## IHTSDO (SNOMED CT)

This material includes SNOMED Clinical Terms™ (SNOMED CT®) which is used by permission of the International Health Terminology Standards Development Organisation (IHTSDO). All rights reserved. SNOMED CT® was originally created by The College of American Pathologists. “SNOMED” and “SNOMED CT” are registered trademarks of the IHTSDO, (<http://www.ihtsdo.org/>).

## HL7 International

This document includes excerpts of HL7™ International standards and other HL7 International material. HL7 International is the publisher and holder of copyright in the excerpts. The publication, reproduction and use of such excerpts is governed by the HL7 IP Policy (see <http://www.hl7.org/legal/ippolicy.cfm>) and the HL7 International License Agreement. HL7 and CDA are trademarks of Health Level Seven International and are registered with the United States Patent and Trademark Office.



DRAFT

# Table of Contents

<b>1. Introduction</b>	1
1.1. Document Purpose and Scope	1
1.2. Pathology Report with Structured Clinical Content Definition	1
1.3. HL7 Clinical Document Architecture	1
1.4. Intended Audience	2
1.5. Document Map	2
1.6. Acronyms	3
1.7. Keywords	3
1.8. Conformance	4
1.9. Known Issues	5
<b>2. Guide for Use</b>	9
2.1. Clinical Document Architecture Release 2	9
2.2. Mapping Interpretation	11
2.3. CDA Extensions	22
2.4. W3C XML Schema	23
2.5. Schematron	24
2.6. Implementation Strategies	25
<b>3. Pathology Report with Structured Clinical Content Data Hierarchy</b>	27
<b>4. Administrative Observations</b>	33
<b>5. CDA Header</b>	37
5.1. ClinicalDocument	37
5.1.1. LegalAuthenticator	42
5.1.2. Custodian	48
<b>6. Context Data Specification - CDA Mapping</b>	53
6.1. Pathology Report with Structured Clinical Content (PATHOLOGY REPORT)	53
6.1.1. SUBJECT OF CARE	58
6.1.2. DOCUMENT AUTHOR	78
6.1.3. ORDER DETAILS	87
6.1.4. REQUESTER	92
<b>7. Content Data Specification - CDA Mapping</b>	105
7.1. Pathology Report with Structured Clinical Content	105
7.1.1. PATHOLOGY	109
7.1.1.1. PATHOLOGY TEST RESULT	113
7.1.1.1.1. Test Specimen Detail (SPECIMEN)	129
7.1.1.1.2. Result Group (PATHOLOGY TEST RESULT GROUP)	143
7.1.1.1.2.1. Individual Pathology Test Result Value Reference Ranges (REFERENCE RANGE DETAILS)	154
7.1.1.1.2.2. Result Group Specimen Detail (SPECIMEN)	159
7.1.1.1.3. REPORTING PATHOLOGIST	173
7.1.1.2. REPORTING PATHOLOGIST	184
7.1.1.3. RELATED DOCUMENT	193
<b>8. Common Patterns</b>	201
8.1. code	201
8.2. id	203
8.3. time	205
8.4. Entity Identifier	207
8.5. Person Name	209
8.6. Address	211
8.7. Electronic Communication Detail	216
8.8. Employment	218
<b>9. NEHTA CDA Extensions</b>	223
9.1. ClinicalDocument.completionCode	223
9.2. EntityIdentifier	224
9.3. Entitlement	225
9.4. Multiple Birth	226
9.5. Administrative Gender Code	227
9.6. Birth Time	228
9.7. Deceased Time	229

9.8. Employment .....	230
9.9. Qualifications .....	231
9.10. Container .....	232
<b>10. Vocabularies and Code Sets .....</b>	<b>233</b>
10.1. HL7: TelecommunicationAddressUse .....	233
10.2. AS 5017-2006 Health Care Client Identifier Sex .....	235
10.3. AS 5017-2006: Health Care Client Name Usage .....	236
10.4. AS 4846-2006: Health Care Provider Organisation Name Usage .....	237
10.5. AS 5017-2006: Health Care Client Source of Death Notification .....	238
10.6. AS 5017-2006: Health Care Client Identifier Address Purpose .....	239
10.7. AS 5017-2006: Health Care Client Identifier Geographic Area .....	240
10.8. AS 5017-2006: Health Care Client Electronic Communication Medium .....	241
10.9. AS 5017-2006: Health Care Client Electronic Communication Usage Code .....	243
10.10. AS 5017-2006 Australian State/Territory Identifier - Postal .....	244
10.11. AS 5017-2006 Health Care Client Identifier Date Accuracy Indicator .....	245
10.12. NCTIS: Admin Codes - Document Status .....	247
10.13. NCTIS: Admin Codes - Entitlement Type .....	248
10.14. HL7 v3 CDA: Act.moodCode .....	249
10.15. HL7 v3 CDA: RelatedDocument.typeCode .....	250
10.16. METeOR 291036: Indigenous Status .....	251
10.17. CodeSystem OIDs .....	252
10.18. HL7 V3: ObservationInterpretationNormality .....	253
10.19. HL7: Diagnostic Service Section ID .....	254
10.20. HL7: Result Status .....	256
<b>A. CDA Narratives .....</b>	<b>257</b>
Reference List .....	259

## List of Examples

2.1. Mapping Interpretation .....	19
4.1. Administrative Observations XML Fragment .....	36
5.1. ClinicalDocument Body XML Fragment .....	41
5.2. LegalAuthenticator XML Fragment .....	46
5.3. Custodian Body XML Fragment .....	51
6.1. Pathology Report with Structured Clinical Content Context XML Fragment .....	56
6.2. SUBJECT OF CARE XML Fragment .....	73
6.3. DOCUMENT AUTHOR XML Fragment (PERSON Healthcare Provider) .....	84
6.4. ORDER DETAILS XML Fragment .....	91
6.5. REQUESTER XML Fragment .....	102
7.1. Pathology Report with Structured Clinical Content Body XML Fragment .....	108
7.2. PATHOLOGY XML Fragment .....	112
7.3. PATHOLOGY TEST RESULT XML Fragment .....	125
7.4. Test Specimen Detail (SPECIMEN) XML Fragment .....	139
7.5. Result Group (PATHOLOGY TEST RESULT GROUP) XML Fragment .....	151
7.6. Individual Pathology Test Result Value Reference Ranges (REFERENCE RANGE DETAILS) XML Fragment .....	157
7.7. Result Group Specimen Detail (SPECIMEN) XML Fragment .....	169
7.8. REPORTING PATHOLOGIST XML Fragment .....	181
7.9. REPORTING PATHOLOGIST XML Fragment .....	190
7.10. RELATED DOCUMENT XML Fragment .....	199
8.1. code .....	202
8.2. id .....	204
8.3. Simple timestamp .....	205
8.4. Low time .....	205
8.5. Interval timestamp 1 .....	205
8.6. Interval timestamp 2 .....	206
8.7. Width time .....	206
8.8. Entity Identifier .....	208
8.9. Person Name .....	210
8.10. Address .....	215
8.11. Electronic Communication Detail .....	217
8.12. Employment .....	220
10.1. All values .....	233
10.2. One value .....	233

DRAFT

# 1 Introduction

## 1.1 Document Purpose and Scope

This document provides a guide to implementing the logical model detailed by NEHTA's Pathology Report with Structured Clinical Content (PR) Structured Content Specification (SCS) as an HL7 Clinical Document Architecture (CDA) Release 2 XML document. This implementation guide is based on Version 1.0 of the PR SCS [NEHT2016g]. The primary aim of the implementation guide is to take implementers step by step through mapping each data component of the PR SCS to a corresponding CDA attribute or element.

This implementation guide contains descriptions of both constraints on the CDA and, where necessary, custom extensions to the CDA, for the purposes of fulfilling the requirements for Australian implementations of PR. The resulting CDA document can be used for the electronic exchange of PR information between healthcare providers.

In addition, this implementation guide presents conformance requirements against which implementers can attest the conformance of their systems.

This release is intended to inform, and seek feedback from, prospective software system designers and their clinical consultants.

The National Clinical Terminology and Information Service (NCTIS) values your questions, comments and suggestions about this document. Please direct your questions or feedback to <[help@nehta.gov.au](mailto:help@nehta.gov.au)>.

## 1.2 Pathology Report with Structured Clinical Content Definition

A Pathology Report is defined in the PR SCS [NEHT2016g] as:

A set of one or more results of pathology tests and their associated interpretation.

## 1.3 HL7 Clinical Document Architecture

CDA is a document markup standard that specifies the structure and semantics of clinical documents for the purpose of supporting interoperable exchange and use at human and system levels.

CDA has been chosen as the format for electronic clinical documents because it is consistent with NEHTA's commitment to a service and document-oriented approach to electronic information exchange, which will contribute to future electronic health records.

Some of the advantages of CDA are:

- It is machine computable and human readable.
- It provides a standardised display of clinical information without loss of clinical meaning.
- It provides assurance of clinical quality and safety more effectively than message-based interfaces, by storing and displaying the clinical data as entered by the clinician.
- It provides better support than HL7 V2 messages for:
  - more complex information structures, such as pathology synoptic reporting; and
  - terminologies such as SNOMED CT.

- It supports legal attestation by the clinician (requiring that a document has been signed manually or electronically by the responsible individual).
- It is able to be processed by unsophisticated applications (displayed in web browsers, for instance).
- It provides a number of levels of compliance to assist with technical implementation and migration.
- It aligns Australia with e-health initiatives in other countries (such as Canada, UK, USA, Brazil, Germany and Finland).

## 1.4 Intended Audience

This document is aimed at software development teams, architects, designers, clinicians and informatics researchers who are responsible for the delivery of clinical applications, infrastructure components and messaging interfaces, and also for those who wish to evaluate the clinical suitability of NEHTA-endorsed specifications.

This document and related artefacts are technical in nature and the audience is expected to be familiar with the language of health data specifications and to have some familiarity with health information standards and specifications, such as CDA and Standards Australia IT-014 documents. Definitions and examples are provided to clarify relevant terminology usage and intent.

## 1.5 Document Map

This implementation guide is not intended to be used in isolation. Companion documents are listed below:

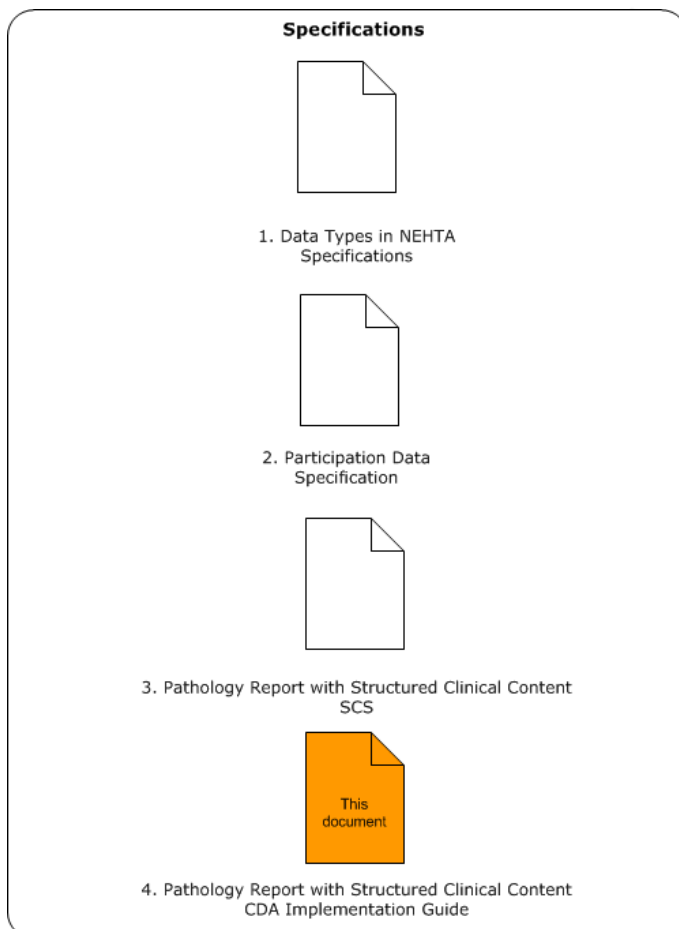

1. [Data Types in NEHTA Specifications: A Profile of the ISO 21090 Specification \[NEHT2010c\]](#) is a detailed description of the data types used within the structured content specification.

2. *Participation Data Specification [NEHT2011v]* contains the full specification which forms the basis of all participations contained in NEHTA structured content specifications.

3. *Pathology Report with Structured Clinical Content Structured Content Specification [NEHT2016g]* is a clinical content specification describing the logical data structures, data components, and value domains which constitute a Pathology Report.

## 1.6 Acronyms

CDA	Clinical Document Architecture
HL7	Health Level Seven
OID	Object Identifier
PR	Pathology Report with Structured Clinical Content
RIM	Reference Information Model
SCS	Structured Content Specification
UUID	Universally Unique Identifier
XHTML	Extensible Hypertext Markup Language
XML	Extensible Markup Language
XSD	XML Schema Definition
XSL	Extensible Stylesheet Language

For a complete listing of all relevant acronyms, abbreviations and a glossary of terms please refer to [NEHTA Acronyms, Abbreviations & Glossary of Terms \[NEHT2005a\]](#).

## 1.7 Keywords

Where used in this document, the keywords **SHALL**, **SHOULD**, **MAY**, **SHALL NOT** and **SHOULD NOT** are to be interpreted as described in [Key words for use in RFCs to Indicate Requirement Levels \[RFC2119\]](#).

### Keywords used in this document

Keyword	Interpretation
<b>SHALL</b>	This word, or the term <b>REQUIRED</b> , means that the statement is an absolute requirement of the specification.
<b>SHOULD</b>	This word, or the term <b>RECOMMENDED</b> , means that there may exist valid reasons in particular circumstances to ignore a particular item, but the full implications must be understood and carefully weighed before choosing a different course.
<b>MAY</b>	This word, or the term <b>OPTIONAL</b> , means that an item is truly optional. One implementer may choose to include the item because a particular implementation requires it, or because the implementer determines that it enhances the implementation while another implementer may omit the same item. An implementation which does not include a particular option must be prepared to interoperate with another implementation which does include the option, perhaps with reduced functionality. In the same vein, an implementation which does include a particular option must be prepared to interoperate with another implementation which does not include the option (except of course, for the feature the option provides).
<b>SHALL NOT</b>	This phrase means that the statement is an absolute prohibition of the specification.
<b>SHOULD NOT</b>	This phrase, or the phrase <b>NOT RECOMMENDED</b> means that there may exist valid reasons in particular circumstances when the particular behaviour is acceptable or even useful, but the full implications should be understood and the case carefully weighed before implementing any behaviour described with this label.



# 1.8 Conformance

This document describes how the PR SCS is implemented as a CDA document. Conformance claims are not made against this implementation guide directly; rather, they are made against additional conformance profiles documented elsewhere. Any document that claims conformance to any derived conformance profile **SHALL** meet these base requirements:

- It **SHALL** be a valid HL7 CDA instance. In particular:
  - It **SHALL** be valid against the HL7 CDA Schema (once extensions have been removed, see [W3C XML Schema](#)).
  - It **SHALL** conform to the HL7 V3 R1 data type specification.
  - It **SHALL** conform to the semantics of the RIM and Structural Vocabulary.
- It **SHALL** be valid against the NEHTA CDA Schema that accompanies this implementation guide after any additional extensions not in the NEHTA extension namespace have been removed, along with any other CDA content not described by this implementation guide.
- It **SHALL** use the mappings as they are stated in this document.
- It **SHALL** use all fixed values specified in the mappings (e.g. `@attribute="FIXED_VALUE"`).
- If the vocabulary has been explicitly stated as 'NS' it **SHALL** be interpreted as:

NS = In the absence of national standard code sets, the code sets used **SHALL** be registered code sets, i.e. registered through the [HL7 code set registration procedure](#)<sup>1</sup> with an appropriate object identifier (OID), and **SHALL** be publicly available.

When national standard code sets become available, they **SHALL** be used and the non-standard code sets **SHALL** be deprecated.

- It **SHALL** be valid against the additional conformance requirements that are established in this document (i.e. any normative use of the word 'shall' identified by the term presented in uppercase and bold typeface).
- The narrative **SHALL** conform to the requirements described in this implementation guide.
- The document **SHALL** conform to the requirements specified in the CDA Rendering Specification [\[NEHT2012s\]](#).
- The data as contained in the data types **SHALL** conform to the additional data type specification [\[NEHT2010c\]](#).
- Any additional content included in the CDA document that is not described by this implementation guide **SHALL NOT** qualify or negate content described by this implementation guide and it **SHALL** be clinically safe for receivers of the document to ignore the non-narrative additions when interpreting the existing content.

A system that *consumes* PR CDA documents may claim conformance if it correctly processes conformant instance documents, including correctly understanding all the information in the header. It may, but is not required to, reject non-conformant documents. Conformant systems that consume PR CDA documents are not required to process any or all of the structured data entries in the CDA document, but they **SHALL** be able to correctly render the document for end-users when appropriate (see [Clinical Document Architecture Release 2](#)).

Conformance profiles of this document **MAY** make additional rules that override this document in regard to:

- Allowing the use of alternative value sets in place of the value sets specified in this document.
- Allowing the use of alternative identifiers in place of the Healthcare Identifiers Service identifiers.
- Making required data elements and section divisions optional.

<sup>1</sup> <http://www.hl7.org/oid/index.cfm?ref=footer>

## 1.9 Known Issues

This section lists known issues with this specification at the time of publishing. NEHTA is working on solutions to these issues, and we encourage comments to further assist the development of these solutions.

Reference	Description
Throughout document: XML Examples	<p>While every effort has been taken to ensure that the examples are consistent with the normative mappings in this message specification, care needs to be taken when copying XML examples for implementation and validation.</p> <p>Where there are conflicts with the written message specification or schema and the xml examples, the specification or schema takes precedence.</p>
Throughout document: R-MIMs	<p>While every effort has been taken to ensure that the R-MIM diagrams are consistent with the normative mappings in this message specification, there may be a few discrepancies between R-MIM diagrams and CDA mapping tables. The CDA mapping takes precedence if there are discrepancies.</p>
Throughout document: Participation types	<p>The participation types in the OID register are not exhaustive, hence the absence of a participation type is not an error.</p>
Throughout document	<p>Australian vs American spelling - in cases where definitions have been taken from HL7 documentation, the American spelling has been preserved, e.g. organization rather than organisation.</p>
6.1.4 REQUESTER	<p>The mapping for the Requester of the report does not follow the data hierarchy as specified in the SCS because CDA does not allow (without extensions) participations on Order in the header.</p>
7.1.1.1 PATHOLOGY TEST RESULT	<p>The <i>PATHOLOGY TEST RESULT</i> data group is mapped as a Section, however it would be more appropriate to map it as the Observation that has <i>Pathology Test Result Name</i> mapped to its code element.</p>
7.1.1.1 PATHOLOGY TEST RESULT 7.1.1.1 PATHOLOGY TEST RESULT :: Pathology Test Result Name	<p>The mapping of the <i>Pathology Test Result Name</i> logical data element (and by implication <i>PATHOLOGY TEST RESULT</i>) is to an Observation, however no logical data elements are mapped to the value element of that Observation. An Observation without a value is meaningless calling into question the mapping of <i>Pathology Test Result Name</i> (and by implication <i>PATHOLOGY TEST RESULT</i>) to an Observation.</p>
7.1.1.1 PATHOLOGY TEST RESULT :: Overall Pathology Test Result Status	<p>The current mapping of the <i>Overall Pathology Test Result Status</i> logical data element to the value element of a subordinate Observation of the <i>Pathology Test Result</i> Observation is semantically weak. This mapping was forced by the choice of logical value domain; consideration should be given to instead using the <i>statusCode</i> element of the <i>Pathology Test Result</i> Observation.</p>

Reference	Description
7.1.1.1 PATHOLOGY TEST RESULT :: Overall Test Result Status (Overall Pathology Test Result Status) 7.1.1.3 RELATED DOCUMENT :: Report Status (Document Status)	There are multiple known issues in the SCS related to the use of the proposed codeSystem HL7 Result Status (2.16.840.1.113883.12.123) for this data component; significantly this is not the codeSystem mandated for the same data components in other NEHTA specifications which impacts on interoperability.
7.1.1.1 PATHOLOGY TEST RESULT :: Test Requested Name	The <i>Test Requested Name</i> logical element is mapped as the value element of a subordinate Observation to the <i>TEST REQUEST DETAILS</i> Act. However, it would be more appropriate to map it as the code element of the <i>TEST REQUEST DETAILS</i> Act.
7.1.1.1 PATHOLOGY TEST RESULT :: Test Result Representation	The cardinality range of <i>Test Result Representation</i> should be 0..* instead of 0..1. The intention of this logical element is to allow multiple semantically equivalent formats. This allows a sender to send all the formats they can comfortably populate and the reader can then pick the one they can best render.
7.1.1.1 PATHOLOGY TEST RESULT :: Observation DateTime	The <i>Observation DateTime</i> logical element is mapped as the effectiveTime element of a subordinate Observation to the <i>Pathology Test Result</i> Observation. However, it would be more appropriate to map it as the effectiveTime element of the <i>Pathology Test Result</i> Observation.
7.1.1.1.1 Test Specimen Detail (SPECIMEN) 7.1.1.1.2.2 Result Group Specimen Detail (SPECIMEN)	The mapping of the <i>SPECIMEN</i> logical data group is to an Observation, however no logical data elements are mapped to the value element of that Observation. An Observation without a value is meaningless calling into question the mapping of <i>SPECIMEN</i> to Observation.
7.1.1.1.1 Test Specimen Detail (SPECIMEN) :: Anatomical Location Image 7.1.1.1.1 Test Specimen Detail (SPECIMEN) :: Image	Both <i>Anatomical Location Image</i> and <i>Image</i> are mapped as subordinate ObservationMedia of the <i>SPECIMEN</i> Observation; there is no provided means to differentiate which ObservationMedia represents the logical data element <i>Anatomical Location Image</i> and which represents the logical data element <i>Image</i> .
7.1.1.1.2 Result Group (PATHOLOGY TEST RESULT GROUP) :: Individual Pathology Test Result Value	The current mapping of the <i>Individual Pathology Test Result Status</i> data type may be too restrictive and is expected to be relaxed in future.  It is recommended that data types without units, e.g. ST or INT, are avoided where possible so that machine-level semantic interoperability is not compromised.
7.1.1.1.2 Result Group (PATHOLOGY TEST RESULT GROUP) :: Individual Pathology Test Result Status	The current mapping of the <i>Individual Pathology Test Result Status</i> logical data element to the value element of a subordinate Observation of the <i>PATHOLOGY TEST RESULT GROUP</i> Observation is semantically weak. This mapping was forced by the choice of logical value domain; consideration should be given to instead using the statusCode element of the <i>PATHOLOGY TEST RESULT GROUP</i> Observation.
7.1.1.1.2.2 Result Group Specimen Detail (SPECIMEN) :: Anatomical Location Image 7.1.1.1.2.2 Result Group Specimen Detail (SPECIMEN) :: Image	Both <i>Anatomical Location Image</i> and <i>Image</i> are mapped as subordinate ObservationMedia of the <i>SPECIMEN</i> Observation; there is no provided means to differentiate which ObservationMedia represents the logical data element <i>Anatomical Location Image</i> and which represents the logical data element <i>Image</i> .

Reference	Description
7.1.1.1.2.1 Individual Pathology Test Result Value Reference Ranges (REFERENCE RANGE DETAILS)	The logical model reference range data components have changed as a result of ongoing development, however no changes to the mappings for reference range data components have been included in this specification. Representing these changes in CDA would effect a normative change to current implementation which is beyond the scope of the release of this document.
7.1.1.2 REPORTING PATHOLOGIST	The mapping for the Reporting Pathologist does not follow the data hierarchy as specified in the SCS because CDA does not cater well for this type of participant in the header.
7.1.1.2 REPORTING PATHOLOGIST	The mapping for the Reporting Pathologist to an author participant may not correctly represent the semantics of this participation. A CDA participant class with a typeCode of "RESP" may be more appropriate.
7.1.1.3 RELATED DOCUMENT :: Test Result Representation (Document Target)	Multiple MIME types are listed as allowed, however the PCEHR system requires all Pathology Report with Structured Clinical Contents to use only PDF.
8.5 Person Name :: Preferred Name Indicator code	The "PRF" code for "preferred name" has been approved by the HL7 Patient Administration Workgroup to be added to Table 0200 Name Type. The updated table will be published in HL7 v2.8.2 after ballot in November 2014.
10 Vocabularies and Code Sets: AS 4846-2006 and AS 5017-2006 superseded	AS 4846-2014 <i>Person and provider identification in healthcare</i> has been published and supersedes both AS 4846-2006 <i>Healthcare provider identification</i> and AS 5017-2006 <i>Healthcare client identification</i> .
AS 5017-2006: Health Care Client Identifier Geographic Area	The Health Care Client Identifier Geographic Area vocabulary table lists displayName, code, codeSystemName and codeSystem, while only the displayName is used in the mapping. Verification of using only the displayName needs to be performed.

DRAFT

## 2 Guide for Use

This document describes how to properly implement the PR SCS [NEHT2016g] as a conformant HL7 CDA XML document. The PR specification is contained in two publications:

- 1) A logical specification, which, in conjunction with its related documents (see [Document Map](#)), describes the Pathology Report with Structured Clinical Content in a form that is consistent with other NEHTA specifications. It has the potential to be implemented in multiple different exchange formats as is most suitable for a particular context. It describes the data content of a Pathology Report as a hierarchy of data components and provides documentation concerning their use and meaning.
- 2) An implementation guide (this document), which specifies how the data described in the SCS is properly represented in a CDA document.

In order to properly implement this specification, the reader should be familiar with the PR SCS and the HL7 CDA documentation, and understand how to read this document.

For further information regarding NEHTA structured content specifications, see the links in [Document Map](#).

### 2.1 Clinical Document Architecture Release 2

A CDA document is an XML document built following the rules described in the CDA specification, which conforms to the HL7 CDA Schema provided by HL7. The CDA document is based on the semantics provided by the [HL7 V3 RIM, Data types and Vocabulary \[HL7V3DT\]](#).

A CDA document has two main parts: the header and the body.

The CDA document header is consistent across all CDA documents, regardless of document type. The header identifies and classifies the document and provides information on authentication, the encounter, the patient, and the involved providers.

The body contains the clinical report. The body can be marked-up text (narrative, renderable text) or a combination of both marked-up text and structured data. The marked-up text can be transformed to XHTML and displayed to a human. The structured data allows machine processing of the information shown in the narrative section.

It is a requirement that all of the clinical information **SHALL** be marked up in CDA narratives. These narratives are CDA-defined hypertext, able to be rendered in web browsers with only a standard accompanying transformation. This transformation is produced and distributed by HL7.

It is a conformance requirement that the rendered narrative **SHALL** be able to stand alone as a source of authenticated information for consuming parties. Content from the CDA body **SHALL NOT** be omitted from the narrative.

Further information and guidance on the CDA narrative is available in [Appendix A, CDA Narratives](#).

The following references are recommended to gain a better understanding of CDA:

- *HL7 Clinical Document Architecture [HL7CDAR2]*
- *HL7 V3 RIM, Data types and Vocabulary [HL7V3DT]*
- *CDA Examples [RING2009]*
- *CDA Validation Tools: infoway\_release\_2\_2X\_18.zip [INFO2009]*

## 2.2 Mapping Interpretation

The core of this implementation guide is a mapping from the PR SCS to the CDA document representation.

The mappings may not be deterministic; in some cases the differences in approach between the logical model specified in the SCS and the CDA implementation guide makes it inappropriate to have a 1:1 mapping, or any simple mapping that can be represented in a transform. This is especially true for names and addresses, where the SCS requirements, based on Australian Standards such as AS 5017 2006, differ from the HL7 data types and vocabularies which are not based on these standards.

Many of the mappings use one of several common patterns for mapping between the SCS and the CDA document. These common mapping patterns are described in [8 Common Patterns](#).

An example of a mapping section of this implementation guide is illustrated below.

### x.x ITEM NAME

#### Identification (normative)

Name	ITEM NAME
Metadata type	Metadata type e.g. Section, Data Group or Data Element

#### Relationships (normative)

##### Children

Data Type	Name	Occurrence
Icon illustrating the Metadata or Data type.	ITEM NAME (This is a link to another section containing the mapping for this item. Item names in upper case indicate that the item is a section or data group. Item names in title case indicate that the item is a data element).	The number of instances of this child item that may occur.



**Parent**

<b>Data Type</b>	<b>Name</b>	<b>Occurrences (child within parent)</b>
Icon illustrating the Metadata or Data type.	ITEM NAME (This is a link to another section containing the mapping for this item. Item names in upper case indicate that the item is a section or data group. Item names in title case indicate that the item is a data element).	The number of instances of the child item within the parent that may occur.

# CDA R-MIM Representation

The text contains an explanation of the mapping (this text is non-normative).

The model is a constrained representation of the R-MIM (this diagram is non-normative). The colours used in the CDA model align with the usage in the R-MIM. In many cases the cardinalities shown in the model will be less constrained than those shown in the mapping table.

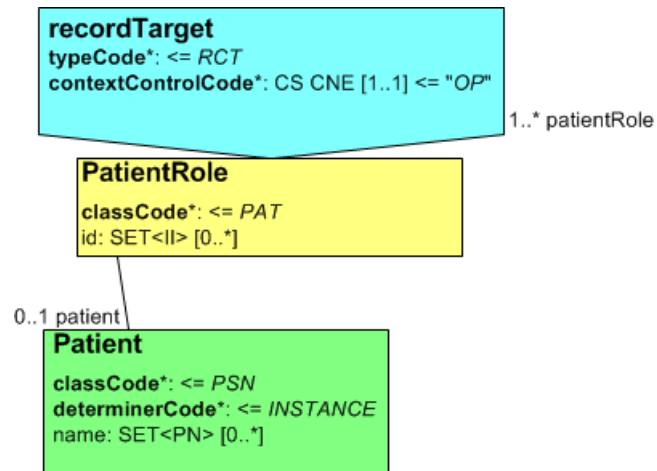

Figure 2.1. Example - Header Part

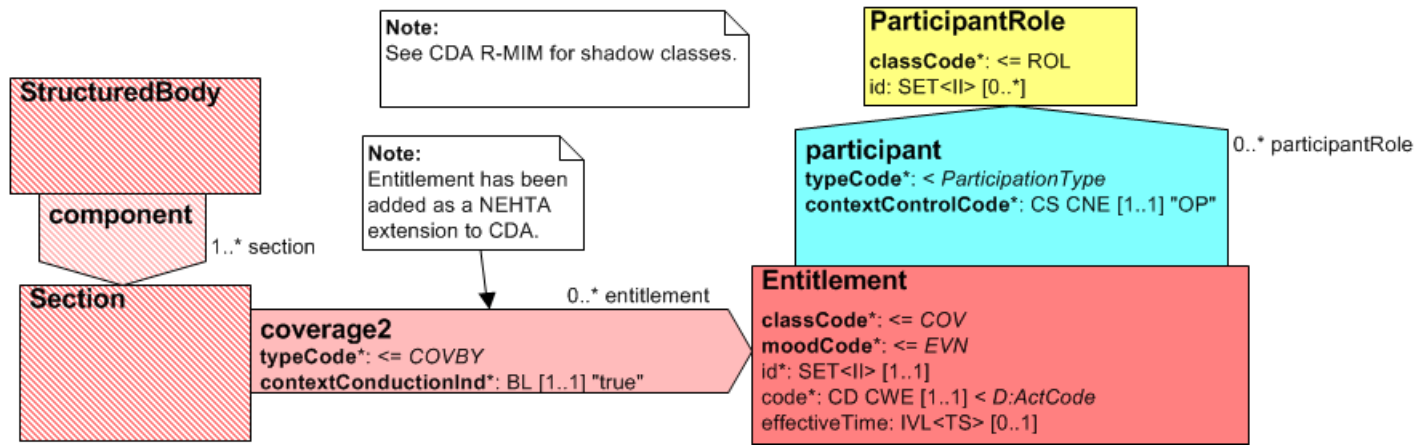

Figure 2.2. Example - Body Part

# CDA Mapping (normative)

NEHTA SCS Data Component	Data Component Definition	Card	CDA Schema Data Element	Vocab	Comments
<b>CDA Element Type (Header, Body Level 2 etc.)</b>			Context: Parent of elements below		
<p>The path in the SCS.</p> <p>Each section in this document corresponds to an SCS section or data group, and is scoped by that section or data group. The hierarchical path uses "&gt;" as a separator for paths within the SCS data hierarchy.</p> <p>If there is a name in round brackets after the path, this is the name of the reused data group for the SCS component.</p> <p>The data component in <b>bold</b> text (the last in the path) is the data component for this row.</p> <p>i.e. Parent Data Component &gt; <b>Child Data Component</b></p>	<p>The definition of the item from the SCS.</p>	<p>The cardinality of the data element in the SCS.</p> <p>The cardinality of the data element in the SCS maps to the cardinality of the element in the CDA document.</p> <p>Where the cardinality of the SCS data element is more constrained than the cardinality of the CDA element then the SCS cardinality takes precedence. That is, if an element is mandatory in the SCS and optional in CDA then it will also become mandatory in the CDA document.</p> <p>If an item with a maximum cardinality &gt; 1 maps to an xml attribute, the attribute will contain multiple values separated by spaces. No such item will have valid values that themselves contain spaces.</p>	<p>The schema element(s) in the CDA document that correspond(s) to the SCS data component.</p> <p>The syntax for this is similar to XPath: {/name{[index]}n{&lt;pattern&gt;}</p> <p>Where:</p> <ul style="list-style-type: none"> <li>{ } indicates optional</li> <li>{ }n means a section that may repeat</li> <li>&lt;pattern&gt; contains a link to a common pattern</li> <li>[index] differentiates two similar mappings</li> </ul> <p>Examples:</p> <ol style="list-style-type: none"> <li>component/act/participation[inf_prov]/role/&lt;Address&gt;</li> <li><b>participant</b> participant/@typeCode="ORG" participant/associatedEntity participant/associatedEntity/@classCode="SDLOC" participant/associatedEntity/code</li> </ol> <p>A sequence of names refers to the XML path in the CDA document. The path always starts from a defined context which is defined in the grey header row above each group of mapping rows. The last name is shown in bold to make the path easier to read. The last name may be a reference to an attribute or an element, as defined in the NEHTA CDA Schema. The cardinalities of the items map through from the SCS.</p> <p>It is possible to specify an index after the name, such as 'participation[inf_prov]' in Example 1. The presence of the index means there are two or more mappings to the same participation class that differ only in the inner detail. The indexes show which of the multiple mappings is the parent of the inner detail. Note that each of the indexed participations may exist more than once (as specified by the SCS group cardinality). To determine the mapping for these kinds of elements, a document reader must look at the content inside the element.</p> <p>It is possible for one SCS data component to map to more than one CDA schema element as in Example 2.</p> <p>Any fixed attribute values are represented as a separate line of the mapping, such as those shown in Example 2.</p> <p>The path may end with a pattern designator, such as &lt;Address&gt;. This indicates that the mapping involves a number of sub-elements of the named element following the pattern, as shown in the name (which is a link to the appropriate pattern in this document).</p>	<p>The name of the vocabulary.</p>	<p>Helpful additional information about the mapping.</p>

## How to interpret the following example mapping:

NEHTA SCS Data Component	Data Component Definition	Card	CDA Schema Data Element	Vocab	Comments
<b>CDA Header Data Elements</b>			Context: ClinicalDocument/		
<b>Subject of Care</b>	Person who receives healthcare services.	1..1	recordTarget/patientRole		
n/a	n/a	1..1	recordTarget/patientRole/id	UUID  This is a technical identifier that is used for system purposes such as matching. If a suitable internal key is not available, a UUID <b>MAY</b> be used.	Required CDA element.  If there are any entitlements for Subject of Care, this value <b>SHALL</b> be the same as: ClinicalDocument/component/structuredBody/component[admin_obs]/section/entry/act/participant/participantRole/id where participantRole/@classCode = "PAT".
Subject of Care > Participant > <b>Person</b>	An individual who is in the role of healthcare provider, who uses or is a potential user of a healthcare service, or is in some way related to, or a representative of, a subject of care (patient).	1..1	n/a		Not mapped directly, encompassed implicitly in recordTarget/patientRole/patient.
Subject of Care > Participant > Person > <b>Person Name</b>	The appellation by which an individual may be identified separately from any other within a social context.	1..*	recordTarget/patientRole/patient/<Person Name>		See common pattern: <a href="#">Person Name</a> .

NEHTA SCS Data Component	Data Component Definition	Card	CDA Schema Data Element	Vocab	Comments
<b>CDA Header Data Elements</b>					
Context: ClinicalDocument/component/structuredBody/component[admin_obs]/section/					
Subject of Care > Participant > <b>Entitlement</b>	The entitlement or right of a participant to act in a given capacity (as defined by Entitlement Type) within a healthcare context.	0..*	<b>ext:coverage2/@typeCode="COVBY"</b>		See NEHTA CDA extension: <a href="#">Entitlement</a> .  All data elements within this section <b>SHALL</b> be deemed as CDA Header data elements for conformance assessment.
			<b>ext:coverage2/ext:entitlement</b>		
			<b>ext:coverage2/ext:entitlement/@classCode="COV"</b>		
			<b>ext:coverage2/ext:entitlement/@moodCode="EVN"</b>		
			<b>ext:coverage2/ext:entitlement/ext:participant/@typeCode="BEN"</b>		
			<b>ext:coverage2/ext:entitlement/ext:participant/ext:participantRole/@classCode="PAT"</b>		
			<b>ext:coverage2/ext:entitlement/ext:participant/ext:participantRole/ext:id</b>	UUID This is a technical identifier that is used for system purposes such as matching. If a suitable internal key is not available, a UUID <b>MAY</b> be used.	<b>SHALL</b> hold the same value as ClinicalDocument/recordTarget/patientRole/id.
Subject of Care > Participant > Entitlement > <b>Entitlement Number</b>	A number or code issued for the purpose of identifying the entitlement or right of a participant to act in a given capacity (as defined by Entitlement Type) within a healthcare context.	1..1	<b>ext:coverage2/ext:entitlement/ext:id</b>		
Subject of Care > Participant > Entitlement > <b>Entitlement Type</b>	The description of the scope of an entitlement.	1..1	<b>ext:coverage2/ext:entitlement/ext:code</b>	<a href="#">NCTIS: Admin Codes - Entitlement Type</a>	See <code> for available attributes.
Subject of Care > Participant > Entitlement > <b>Entitlement Validity Duration</b>	The time interval for which an entitlement is valid.	0..1	<b>ext:coverage2/ext:entitlement/ext:effectiveTime</b>		

The Subject of Care (Patient) section is part of the context section of the SCS (as opposed to being part of the content section of the SCS). Although it is located in the context section of the SCS, it contains data components that map to the CDA body, as well as data components that map to the CDA header. The information specifying the location of the elements is in the shaded context header row located above each group of mapping rows. The context remains the same until a new context header row starts.

The first row of the mapping (after the context header row), 'Subject of Care', is a CDA Header element and has a context of 'ClinicalDocument' (the root element of a CDA document). Adding together the context and the mapping using '/' gives a full path of:

- 1) ClinicalDocument/recordTarget/patientRole

Due to the fact that 'Subject of Care' is part of the context section of the SCS (as opposed to a content element), information about it and its child elements can be located in the SCS document by finding the data component 'Subject of Care' in the table of contents under the context section, and navigating to the relevant page.

If the data component were part of the content section of the SCS, information about it could be located by finding the data component (or its parent) in the table of contents under the content section of the SCS.

- 2) The next row in the mapping (n/a) is a row that is not defined in the SCS but which is required by CDA. The CDA schema data element is recordTarget/patientRole/id. This is a technical identifier that is used for system purposes, such as matching the Entitlement details back to the Subject of Care (patient). This identifier **SHALL** be a UUID.
- 3) The next row in the mapping table (Subject of Care > Participant > Person) is defined in the SCS but is not mapped directly to the CDA because it is already encompassed implicitly by CDA in recordTarget/patientRole/patient.

Moving to the next row in the table (Subject of Care > Participant > Person > **Person Name**) and concatenating the context and the mapping, we get:

- 4) ClinicalDocument/recordTarget/patientRole/patient/<Person Name>

<PersonName> holds a link to the common pattern section where a new table lays out the mapping for the Person Name common pattern.

Moving down the table to the context row '**CDA Header Data Elements**', any data components after this row (until the occurrence of a new context row) map to the CDA body. Because there is no equivalent concept in CDA, a NEHTA CDA extension has been added in order to represent Entitlement. This extension is indicated by the presence of the 'ext:' prefix. The Entitlement CDA elements **SHALL** be deemed CDA Header data elements for conformance assessment. For the data component 'Entitlement', adding together the context and the mapping using '/' gives the following paths for the CDA body level 3 data elements ([index] is dependent on context):

- 5) ClinicalDocument/component/structuredBody/component[index]/section/ext:coverage2/@typeCode="COVBY"
- 6) ClinicalDocument/component/structuredBody/component[index]/section/ext:coverage2/ext:entitlement
- 7) ClinicalDocument/component/structuredBody/component[index]/section/ext:coverage2/ext:entitlement/@classCode="COV"
- 8) ClinicalDocument/component/structuredBody/component[index]/section/ext:coverage2/ext:entitlement/@moodCode="EVN"

9) ClinicalDocument/component/structuredBody/component[index]/section/ext:coverage2/ext:entitlement/ext:participant/@typeCode="BEN"

10) ClinicalDocument/component/structuredBody/component[index]/section/ext:coverage2/ext:entitlement/ext:participant/ext:participantRole/@classCode="PAT"

11) ClinicalDocument/component/structuredBody/component[index]/section/ext:coverage2/ext:entitlement/ext:participant/ext:participantRole/ext:id

This id is also a technical identifier and **SHALL** hold the same value as the ClinicalDocument/recordTarget/patientRole/id mentioned in comment 1.

The order of the SCS data components is not always the same as the order of the CDA elements. In addition, the CDA elements need to be in the order specified in the NEHTA CDA Schema.

The id element is not specified in the SCS and **SHOULD** be filled with a UUID. This element may be used to reference an act from other places in the CDA document.

The next row in the table (Subject of Care > Participant > Entitlement > Entitlement Number) maps to the id element:

12) ClinicalDocument/component/structuredBody/component[index]/section/ext:coverage2/ext:entitlement/ext:id

The next row in the table (Subject of Care > Participant > Entitlement > Entitlement Type) maps to the code element:

13) ClinicalDocument/component/structuredBody/component[index]/section/ext:coverage2/ext:entitlement/ext:code

The next row in the table (Subject of Care > Participant > Entitlement > Entitlement Validity Duration) maps to the effectiveTime element:

14) ClinicalDocument/component/structuredBody/component[index]/section/ext:coverage2/ext:entitlement/ext:effectiveTime

See comments in the example below.

## Example 2.1. Mapping Interpretation

```
<!-- This xml fragment is provided to demonstrate an example instance of each structured element in the CDA Mapping table. It is illustrative only.
Logical model constraints on allowed combinations of child components are ignored in order to provide coverage of structured elements. This fragment cannot be treated as clinically valid.
While the values in the fragment are conformant with the CDA Mapping table they are typically exaggerated to highlight the semantic meaning of the structured elements and
may not be indicative of the expected values in a clinical document.
While every effort has been taken to ensure that the examples are consistent with the message specification, where there are conflicts with the written message specification or schema,
the specification or schema will take precedence. -->
```

```
<ClinicalDocument
  xmlns="urn:hl7-org:v3"
  xmlns:ext="http://ns.electronichealth.net.au/Ci/Cda/Extensions/3.0"
  ...
  >
  ...
  <!-- Begin Subject of Care - Header Part -->
  <recordTarget>
```



```

<!-- 1 Corresponds to:
  '//recordTarget/patientRole'
  in the mapping. -->
<patientRole>
  <!-- 2 Corresponds to:
    '//recordTarget/patientRole/id'
    in the mapping -->
  <id root="04A103C4-7924-11DF-A383-FC69DFD72085"/>
  ...

  <telecom value="tel:0499999999" use="H"/>
  <!-- 3 -->
  <patient>
    <!-- 4 Corresponds to:
      '//recordTarget/patientRole/patient/<Person Name>'
      in the mapping -->
    <name use="L">
      <prefix>Ms</prefix>
      <given>Sally</given>
      <family>Grant</family>
    </name>
    ...
  </patient>
</patientRole>
</recordTarget>
<!-- End Subject of Care - Header Part -->
...

<!-- Begin CDA Body -->
<component>
  <structuredBody>

    <!-- Begin section -->
    <component>
      <section>

        ...

        <!-- Begin Subject of Care Entitlement -->
        <!-- 5 Corresponds to:
          '//ext:coverage2'
          in the mapping. -->
        <ext:coverage2 typeCode="COVBY">
          <!-- 6, 7, 8 Corresponds to:
            '//ext:coverage2/ext:entitlement',
            '//ext:coverage2/ext:entitlement/@classCode="COV"',
            '//ext:coverage2/ext:entitlement/@moodCode="EVN"'
            in the mapping -->
          <ext:Entitlement classCode="COV" moodCode="EVN">
            <!-- 12 Corresponds to:
              '//ext:coverage2/ext:entitlement/ext:id'
              in the mapping -->
            <ext:id root="1.2.36.174030967.0.5" extension="1234567892"
              assigningAuthorityName="Medicare Identifier"/>
            <!-- 13 Corresponds to:
              '//ext:coverage2/ext:entitlement/ext:code'
              in the mapping -->
            <ext:code code="1" codeSystem="1.2.36.1.2001.1001.101.104.16047" codeSystemName="NCTIS Entitlement Type Values" displayName="Medicare Benefits" />
            <!-- 14 Corresponds to:

```

```
        '//ext:coverage2/ext:entitlement/ext:effectiveTime'  
        in the mapping -->  
<ext:effectiveTime>  
    <low value="200701010101+1000"/>  
    <high value="202701010101+1000"/>  
</ext:effectiveTime>  
<!-- 9 Corresponds to:  
    '//ext:coverage2/ext:entitlement/ext:participant/@typeCode="BEN" '  
    in the mapping -->  
<ext:participant typeCode="BEN">  
    <!-- 10 Corresponds to:  
        '//ext:coverage2/ext:entitlement/ext:participant/ext:participantRole/@classCode="PAT" '  
        in the mapping -->  
<ext:participantRole classCode="PAT">  
    <!-- 11 Corresponds to:  
        '//ext:coverage2/ext:entitlement/ext:participant/ext:participantRole/ext:id'  
        in the mapping -->  
    <!-- Same as recordTarget/patientRole/id -->  
    <ext:id root="04A103C4-7924-11DF-A383-FC69DFD72085"/>  
</ext:participantRole>  
</ext:participant>  
</ext:Entitlement>  
</ext:coverage2>  
<!-- End Entitlement -->  
  
    ...  
  
</section>  
</component>  
<!-- End section -->  
  
</structuredBody>  
</component>  
<!-- End CDA Body -->  
</ClinicalDocument>
```

## 2.3 CDA Extensions

The SCS is based on Australian requirements, either as expressed in existing Australian Standards, or based on extensive consultation with major stakeholders. Not all of these requirements are supported by HL7 Clinical Document Architecture Release 2 (CDA).

CDA provides a mechanism for handling this. Implementation guides are allowed to define extensions, provided some key rules are followed:

- Extensions have a namespace other than the standard HL7v3 namespace.
- The extension cannot alter the intent of the standard CDA document. For example, an extension cannot be used to indicate that an observation does not apply where the CDA document requires it.
- HL7 encourages users to get their requirements formalised in a subsequent version of the standard so as to maximise the use of shared semantics.

Accordingly, a number of extensions to CDA have been defined in this implementation guide. To maintain consistency, the same development paradigm has been used as CDA, and all the extensions have been submitted to HL7 for inclusion into a future release of CDA (Release 3 currently under development).

Version 3.0 of these extensions are incorporated in the namespace `http://ns.electronichealth.net.au/Ci/Cda/Extensions/3.0` as shown in the CDA example output throughout this document. Future versions of CDA extensions will be versioned as per the following example:

```
http://ns.electronichealth.net.au/Ci/Cda/Extensions/4.0
```

## 2.4 W3C XML Schema

This document refers to an accompanying CDA W3C XML Schema (referred to in this document as the NEHTA CDA Schema). This schema differs from the base HL7 CDA W3C XML Schema (referred to in this document as the HL7 CDA Schema) as mentioned below:

- NEHTA CDA extensions have been added to the NEHTA CDA Schema.

CDA documents which include extensions will fail to validate against the HL7 CDA Schema – this is a known limitation.

A Pathology Report document that conforms to this specification **SHALL** validate against the NEHTA CDA Schema that accompanies this specification, and **SHALL** validate against the HL7 CDA Schema once the extensions have been removed. Note that merely passing schema validation does not ensure conformance. For more information, refer to [Conformance](#).

## 2.5 Schematron

Many of the rules this document makes about CDA documents cannot be captured in the W3C XML Schema language (XSD) as XSD does not provide a mechanism to state that the value or presence of one attribute is dependent on the values or presence of other attributes (co-occurrence constraints).

Schematron is a rule-based validation language for making assertions about the presence or absence of patterns in XML trees. The rules defined by this document may be captured as Schematron rules. As of this release, the matching Schematron assertions have not yet been developed; NEHTA is considering the distribution of these rules in association with future releases of this implementation guide.

## 2.6 Implementation Strategies

There are many platform-specific implementation options for readers implementing a CDA document according to this guide. Examples of these implementation options include:

- Read or write CDA documents directly using a Document Object Model (DOM) or 3rd Generation Language (3GL) code (or both).
- Transform an existing XML format to and from a CDA document.
- Use a toolkit to generate a set of classes from HL7 CDA Schema or the NEHTA CDA Schema provided with this implementation guide, to read or write documents.
- Use existing libraries, possibly open source, that can read and write CDA documents.

The best approach for any given implementation is strongly dictated by existing architecture, technology and legacy constraints of the implementation project or existing system.



# 3 Pathology Report with Structured Clinical Content Data Hierarchy

















The data hierarchy below provides a logical representation of the data structure of the PR SCS data components.

The data hierarchy is a logical representation of the data components of a Pathology Report, and is not intended to represent how the data contents are represented in a CDA document.





















































## Note

























Items below whose icon is grey are technical identifiers whose purpose is to facilitate interoperability, sharing of data and secondary use. It is typically expected that such identifiers will be generated internally by systems and not displayed to users since they usually have no clinical significance.









	Pathology Report with Structured Clinical Content (PATHOLOGY REPORT)		
CONTEXT			
	SUBJECT OF CARE		1..1
	DOCUMENT AUTHOR		1..1
	Document Instance Identifier		1..1
	Document Type		1..1
	REPORTING PATHOLOGIST		1..1
	ORDER DETAILS		1..1
	REQUESTER		1..1
	Requester Order Identifier (Order Identifier)		0..1
	Requested Test Name (Order Name)		0..1
CONTENT			
	PATHOLOGY		1..1
	PATHOLOGY TEST RESULT		1..*
	Test Result Name (Pathology Test Result Name)		1..1
	Diagnostic Service		1..1
	Test Specimen Detail (SPECIMEN)		1..*
	Specimen Tissue Type		0..1
	Collection Procedure		0..1



				Anatomical Site (ANATOMICAL LOCATION)	0..*
				SPECIFIC LOCATION	0..1
				Anatomical Location Name	0..1
				Side	0..1
				Anatomical Location Description	0..1
				Anatomical Location Image	0..*
				Physical Details (PHYSICAL PROPERTIES OF AN OBJECT)	0..*
				Weight	0..1
				DIMENSIONS	0..1
				Volume	0..1
				Description (Object Description)	0..1
				Image	0..1
				COLLECTION AND HANDLING	0..1
				Sampling Preconditions	0..1
				HANDLING AND PROCESSING	1..1
				Date and Time of Collection (Collection DateTime)	1..1
				Collection Setting	0..1
				Date and Time of Receipt (DateTime Received)	0..1
				IDENTIFIERS	0..1
				Specimen Identifier	0..1
				Parent Specimen Identifier	0..1
				Container Identifier	0..1
				Overall Pathology Test Result Status	1..1
				Clinical Information Provided	0..1
				Result Group (PATHOLOGY TEST RESULT GROUP)	0..*

					Pathology Test Result Group Name	1..1
					Result (INDIVIDUAL PATHOLOGY TEST RESULT)	1..*
					Individual Pathology Test Result Name	1..1
					Result Value (INDIVIDUAL PATHOLOGY TEST RESULT VALUE)	0..1
				  	Individual Pathology Test Result Value	1..1
					Individual Pathology Test Result Value Reference Ranges (REFERENCE RANGE DETAILS)	0..1
					Normal Status	0..1
					REFERENCE RANGE	0..*
					Reference Range Meaning	1..1
					Reference Range	1..1
					Individual Pathology Test Result Comment	0..*
					Individual Pathology Test Result Reference Range Guidance	0..1
					Individual Pathology Test Result Status	1..1
					Result Group Specimen Detail (SPECIMEN)	0..1
					Specimen Tissue Type	0..1
					Collection Procedure	0..1
					Anatomical Site (ANATOMICAL LOCATION)	0..*
					SPECIFIC LOCATION	0..1
					Anatomical Location Name	0..1
					Side	0..1
					Anatomical Location Description	0..1
					Anatomical Location Image	0..*
					Physical Details (PHYSICAL PROPERTIES OF AN OBJECT)	0..*

						Weight	0..1
						DIMENSIONS	0..1
						Volume	0..1
						Description (Object Description)	0..1
						Image	0..1
					COLLECTION AND HANDLING		0..1
						Sampling Preconditions	0..1
					HANDLING AND PROCESSING		1..1
						Date and Time of Collection (Collection DateTime)	1..1
						Collection Setting	0..1
						Date and Time of Receipt (DateTime Received)	0..1
					IDENTIFIERS		0..1
						Specimen Identifier	0..1
						Parent Specimen Identifier	0..1
						Container Identifier	0..1
				Pathological Diagnosis			0..*
				Conclusion (Pathology Test Conclusion)			0..1
				Test Result Representation			0..1
				Test Comment			0..1
				TEST REQUEST DETAILS			0..*
					Requester Order Identifier		0..1
					Test Requested Name		0..*
					Laboratory Test Result Identifier		0..1
				REPORTING PATHOLOGIST			0..1
					Observation DateTime		1..1

			Pathology Test Result Instance Identifier	1..1
			Detailed Clinical Model Identifier	1..1
			Pathology Section Instance Identifier (Pathology Instance Identifier)	1..1
			<b>RELATED DOCUMENT</b>	0..1
			Link Nature	1..1
			Link Role	1..1
			Test Result Representation (Document Target)	1..1
			<b>DOCUMENT DETAILS</b>	1..1
			Document Type	1..1
			Report Name (Document Title)	1..1
			Report DateTime (Effective Period)	1..1
			Report Identifier (Document Identifier)	1..1
			Report Status (Document Status)	1..1
			Section Type	1..1

DRAFT

## 4 Administrative Observations

The PR SCS contains a number of data elements that are logically part of the SCS context, but for which there are no equivalent data elements in the CDA header. These data elements are considered to be "Administrative Observations" about the encounter, the patient or some other participant. Administrative Observations is a CDA section that is created to hold these data components in preference to creating extensions for them.

# CDA R-MIM Representation

Figure 4.1 [Administrative Observations](#) shows a subset of the CDA R-MIM containing those classes being referred to in the CDA Mapping. This data component maps to CDA Body elements.

The Administrative Observations section is composed of a Section class related to its context `ClinicalDocument.structuredBody` through a component relationship.

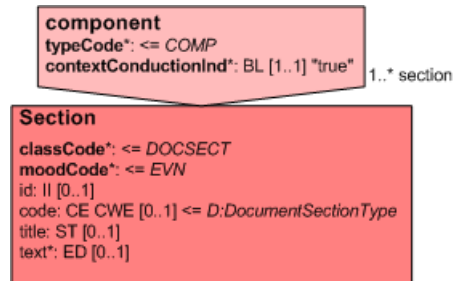

**Figure 4.1. Administrative Observations**

# CDA Mapping

At most one instance of Administrative Observation section **SHOULD** be present in a CDA document. The cardinality of this section comes from its linking context data elements (e.g. CDA context data element(s) mapped to Administrative Observation Section). If any of the linking context data elements are mandatory, then this section **SHALL** be marked as a mandatory section.

This section **SHALL NOT** be populated if there are no entries or text to go in it.

This section **SHALL** contain a code if provided.

All data elements (with the exception of narrative text) within this section **SHALL** be deemed as CDA Header data elements for conformance assessment.

The <text> data element is **OPTIONAL** and **SHALL** be treated as a Level 2 CDA data element.

NEHTA SCS Data Component	Data Component Definition	Card	CDA Schema Data Element	Vocab	Comments	
<b>CDA Body Level 2 Data Elements</b>			Context: ClinicalDocument/component/structuredBody/			
n/a	n/a	Cardinality comes from linking context data elements	<b>component/section[admin_obs]</b>			
		0..1	component/section[admin_obs]/id	UUID This is a technical identifier that is used for system purposes such as matching. If a suitable internal key is not available, a UUID <b>MAY</b> be used.	See <id> for available attributes.	
		1..1	component/section[admin_obs]/code			
			component/section[admin_obs]/code/@code="102.16080"			
			component/section[admin_obs]/code/@codeSystem="1.2.36.1.2001.1001.101"			
			component/section[admin_obs]/code/@codeSystemName	The value <b>SHOULD</b> be "NCTIS Data Components". See <a href="#">CodeSystem OIDs</a> .	Optional CDA element.	
			component/section[admin_obs]/code/@displayName="Administrative Observations"			
		component/section[admin_obs]/title="Administrative Observations"				
0..1	component/section[admin_obs]/text			See <a href="#">Appendix A, CDA Narratives</a> .		



## Example 4.1. Administrative Observations XML Fragment

<!-- This xml fragment is provided to demonstrate an example instance of each structured element in the CDA Mapping table. It is illustrative only. Logical model constraints on allowed combinations of child components are ignored in order to provide coverage of structured elements. This fragment cannot be treated as clinically valid. While the values in the fragment are conformant with the CDA Mapping table they are typically exaggerated to highlight the semantic meaning of the structured elements and may not be indicative of the expected values in a clinical document. While every effort has been taken to ensure that the examples are consistent with the message specification, where there are conflicts with the written message specification or schema, the specification or schema will take precedence. -->

```
<ClinicalDocument
  xmlns="urn:h17-org:v3"
  xmlns:ext="http://ns.electronichealth.net.au/Ci/Cda/Extensions/3.0"
  ...
  >
  <!-- Begin CDA Header -->
  ...
  <!-- End CDA Header -->
  <!-- Begin CDA Body -->
  ...
  <component>
    <structuredBody>
      ...
      <!-- Begin Administrative Observations section -->
      <component typeCode="COMP"><!-- [admin_obs] -->
        <section classCode="DOCSECT" moodCode="EVN">
          <id root="88CDBCA4-EFD1-11DF-8DE4-E4CDDFD72085"/>
          <code code="102.16080"
            codeSystem="1.2.36.1.2001.1001.101"
            codeSystemName="NCTIS Data Components"
            displayName="Administrative Observations"/>
          <title>Administrative Observations</title>
          <!-- Narrative text for Administrative Observations -->
          <text/>
          ...
        </section>
      </component><!-- [admin_obs] -->
      <!-- End Administrative Observations section -->
    </structuredBody>
  </component>
  <!-- End CDA Body -->
</ClinicalDocument>
```

# 5 CDA Header

This chapter contains CDA-specific header elements (both **REQUIRED** and **OPTIONAL**) that are not specified in the PR SCS specification. The CDA Schema Data Element describes each element.

All the definitions in this chapter are sourced from "HL7 Clinical Document Architecture, Release 2" [\[HL7CDAR2\]](#).

## 5.1 ClinicalDocument

### Identification

<b>Name</b>	ClinicalDocument
<b>Definition</b>	The ClinicalDocument class is the entry point into the CDA R-MIM, and corresponds to the <ClinicalDocument> XML element that is the root element of a CDA document.

### Relationships

#### Children

Name	Occurrence
<a href="#">LegalAuthenticator</a>	0..1
<a href="#">Custodian</a>	1..1

## CDA R-MIM Representation

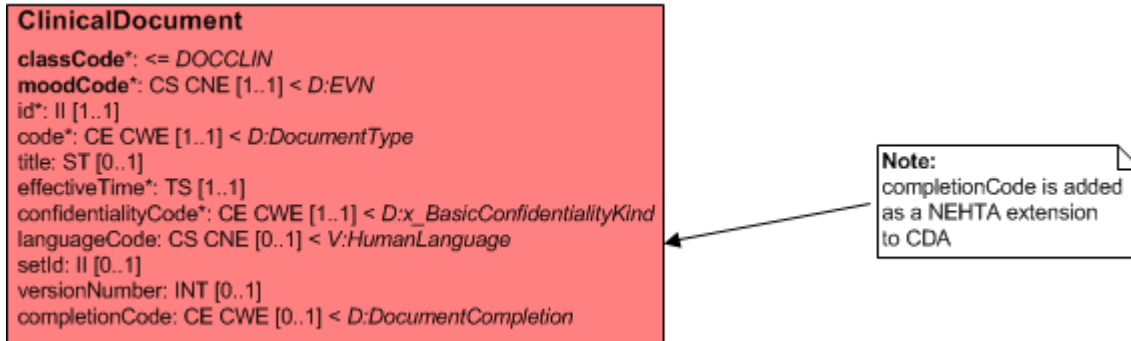

**Figure 5.1. ClinicalDocument**

## CDA Mapping

CDA Schema Data Element	Definition	Card	Vocab	Comments
Context: /				
<b>ClinicalDocument</b>	The ClinicalDocument class is the entry point into the CDA R-MIM, and corresponds to the <ClinicalDocument> XML element that is the root element of a CDA document.	1..1		
ClinicalDocument/ <b>typeld</b>	A technology-neutral explicit reference to the CDA Release 2 specification.	1..1		
ClinicalDocument/typeld/@ <b>extension</b> ="POCD_HD000040"		1..1		The unique identifier for the CDA Release 2 Hierarchical Description.
ClinicalDocument/typeld/@ <b>root</b> ="2.16.840.1.113883.1.3"		1..1		The OID for HL7 Registered models.
ClinicalDocument/ <b>templated</b>		1..*		One or more template identifiers that indicate constraints on the CDA document that this document conforms to. One of the identifiers must be the templated that identifies this specification (see immediately below). Additional template identifiers may be required by other specifications, such as the CDA Rendering Specification.  Systems are not required to recognise any other template identifiers than the one below in order to understand the document as a [type] but these identifiers may influence how the document must be handled.
ClinicalDocument/templated/@ <b>root</b> ="1.2.36.1.2001.1001.100.1002.220"		1..1		The healthcare context-specific name of the published Pathology Report with Structured Clinical Content CDA Implementation Guide.
ClinicalDocument/templated/@ <b>extension</b> ="2.0"		1..1		The identifier of the version that was used to create the document instance.
ClinicalDocument/ <b>id</b>	Represents the unique instance identifier of a clinical document.	1..1		See common pattern: <a href="#">id</a> .
ClinicalDocument/ <b>code</b>	The code specifying the particular kind of document (e.g. History and Physical, Discharge Summary, Progress Note).	1..1		See common pattern: <a href="#">code</a> .
ClinicalDocument/code/@ <b>code</b> ="100.32001"				A set of one or more results of pathology tests and their associated interpretation.
ClinicalDocument/code/@ <b>codeSystem</b> ="1.2.36.1.2001.1001.101"				
ClinicalDocument/code/@ <b>codeSystemName</b>				The value <b>SHOULD</b> be "NCTIS Data Components".  See <a href="#">CodeSystem OIDs</a> .
ClinicalDocument/code/@ <b>displayName</b> ="Pathology Report"				

CDA Schema Data Element	Definition	Card	Vocab	Comments
ClinicalDocument/effectiveTime	Signifies the document creation time, when the document first came into being. Where the CDA document is a transform from an original document in some other format, the ClinicalDocument.effectiveTime is the time the original document is created.	1..1	The value of ClinicalDocument/effectiveTime <b>SHALL</b> include both a time and a date.	See common pattern: <a href="#">time</a> .
ClinicalDocument/confidentialityCode/@nullFlavor="NA"	Codes that identify how sensitive a piece of information is and/or that indicate how the information may be made available or disclosed.	1..1		
ClinicalDocument/languageCode		0..1	<a href="#">[RFC3066]</a> – Tags for the Identification of Languages	<Language Code> – <DIALECT> The <Language Code> <b>SHALL</b> be "en". The <DIALECT> <b>SHOULD</b> be "AU".
ClinicalDocument/setId	Represents an identifier that is common across all document revisions.	1..1	UUID  This is a technical identifier that is used for system purposes such as matching. If a suitable internal key is not available, a UUID <b>MAY</b> be used.	
ClinicalDocument/versionNumber/@value	An integer value used to version successive replacement documents.	1..1		
ClinicalDocument/ext:completionCode	The lifecycle status of a document.	1..1	<a href="#">NCTIS: Admin Codes - Document Status</a>	See NEHTA CDA extension: <a href="#">ClinicalDocument.completionCode</a> .

# Example

## Example 5.1. ClinicalDocument Body XML Fragment

<!-- This xml fragment is provided to demonstrate an example instance of each structured element in the CDA Mapping table. It is illustrative only. Logical model constraints on allowed combinations of child components are ignored in order to provide coverage of structured elements. This fragment cannot be treated as clinically valid. While the values in the fragment are conformant with the CDA Mapping table they are typically exaggerated to highlight the semantic meaning of the structured elements and may not be indicative of the expected values in a clinical document. While every effort has been taken to ensure that the examples are consistent with the message specification, where there are conflicts with the written message specification or schema, the specification or schema will take precedence. -->

```
<ClinicalDocument xmlns="urn:hl7-org:v3"
  xmlns:ext="http://ns.electronichealth.net.au/Ci/Cda/Extensions/3.0"
  xmlns:xs="http://www.w3.org/2001/XMLSchema"
  xmlns:xsi="http://www.w3.org/2001/XMLSchema-instance"
  xsi:schemaLocation="CDA-ES-V1_3.xsd">
  <typeId extension="POCD_HD000040" root="2.16.840.1.113883.1.3"/>
  <templateId root="1.2.36.1.2001.1001.100.1002.220" extension="2.0"/>
  <id root="8BC3406A-B93F-11DE-8A2B-6A1C56D89593"/>
  <code code="100.32001"
    codeSystem="1.2.36.1.2001.1001.101"
    codeSystemName="NCTIS Data Components"
    displayName="Pathology Report"/>
  <effectiveTime value="201211061639+1100"/>
  <confidentialityCode nullFlavor="NA"/>
  <languageCode code="en-AU"/>
  <setId root="6C6BA56C-BC92-11DE-A170-D85556D89593"/>
  <versionNumber value="1"/>
  <ext:completionCode code="F"
    codeSystem="1.2.36.1.2001.1001.101.104.20104"
    codeSystemName="NCTIS Document Status Values"
    displayName="Final"/>

  <!-- Begin CDA Header -->
  ...
  <!-- End CDA Header -->

  <!-- Begin CDA Body -->
  ...
  <!-- End CDA Body -->
</ClinicalDocument>
```

## 5.1.1 LegalAuthenticator

### Identification

<b>Name</b>	LegalAuthenticator
<b>Definition</b>	Represents a participant who has legally authenticated the document.

### Relationships

#### Parent

Name	Occurrences (child within parent)
<a href="#">ClinicalDocument</a>	0..1

## CDA R-MIM Representation

Figure 5.2 LegalAuthenticator shows a subset of the CDA R-MIM containing those classes being referred to in the CDA Mapping. This data component maps to CDA Header elements.

The LegalAuthenticator maps to the CDA Header element legalAuthenticator. The legalAuthenticator participation class represents who has legally authenticated the document. The role is AssignedEntity and is represented by the Person and/or Organization entities.

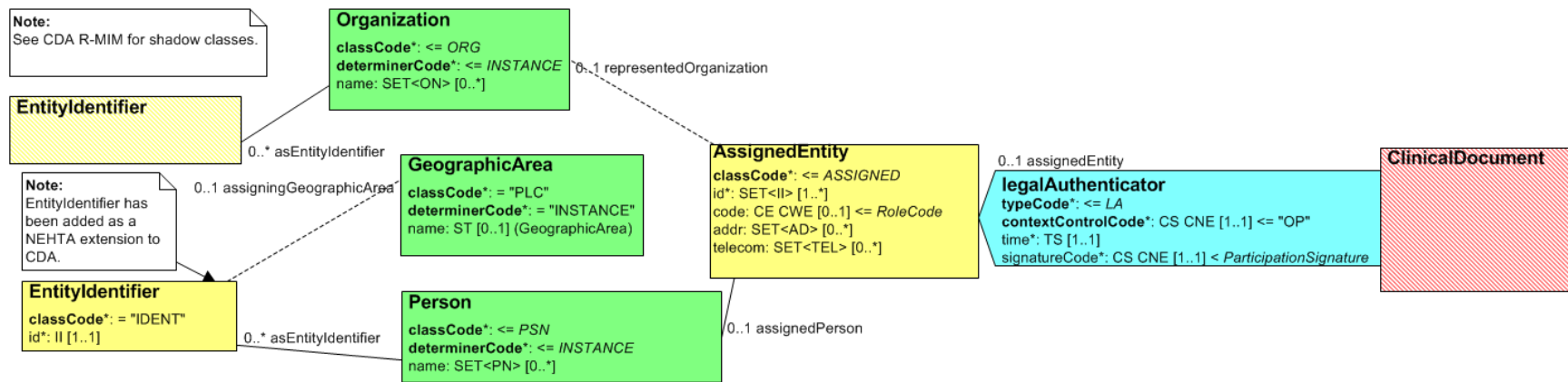

Figure 5.2. LegalAuthenticator



## CDA Mapping



### Note

NS = In the absence of national standard code sets, the code sets used **SHALL** be registered code sets, i.e. registered through the [HL7 code set registration procedure](#)<sup>1</sup> with an appropriate object identifier (OID), and **SHALL** be publicly available.

When national standard code sets become available, they **SHALL** be used and the non-standard code sets **SHALL** be deprecated.

CDA Schema Data Element	Definition	Card	Vocab	Comments
Context: ClinicalDocument/				
<b>legalAuthenticator</b>	Represents a participant who has legally authenticated the document.	0..1		
legalAuthenticator/time/@value	Indicates the time of authentication.	1..1		
legalAuthenticator/signatureCode/@code="S"	Indicates that the signature has been affixed and is on file.	1..1		
legalAuthenticator/assignedEntity	A legalAuthenticator is a person in the role of an assigned entity (AssignedEntity class). An assigned entity is a person assigned to the role by the scoping organization. The entity playing the role is a person (Person class). The entity scoping the role is an organization (Organization class).	1..1		
legalAuthenticator/assignedEntity/code	The specific kind of role.	0..1	NS	See <code> for available attributes.
legalAuthenticator/assignedEntity/id	A unique identifier for the player entity in this role.	1..1	UUID  This is a technical identifier that is used for system purposes such as matching. If a suitable internal key is not available, a UUID <b>MAY</b> be used.	See <id> for available attributes.
legalAuthenticator/assignedEntity/assignedPerson	The entity playing the role (assignedEntity) is a person.	0..1		
legalAuthenticator/assignedEntity/assignedPerson/<Entity Identifier>	The entity identifier of the person.	0..*		See common pattern: <a href="#">Entity Identifier</a> .
legalAuthenticator/assignedEntity/<Address>	A postal address for the entity (assignedPerson) while in the role (assignedEntity).	0..*		See common pattern: <a href="#">Address</a> .
legalAuthenticator/assignedEntity/<Electronic Communication Detail>	A telecommunication address for the entity (assignedPerson) while in the role (assignedEntity).	0..*		See common pattern: <a href="#">Electronic Communication Detail</a> .
legalAuthenticator/assignedEntity/assignedPerson/<Person Name>	A non-unique textual identifier or moniker for the entity (assignedPerson).	0..*		See common pattern: <a href="#">Person Name</a> .

<sup>1</sup> <http://www.hl7.org/oid/index.cfm?ref=footer>

CDA Schema Data Element	Definition	Card	Vocab	Comments
legalAuthenticator/assignedEntity/ <b>representedOrganization</b>	The entity scoping the role (assignedEntity).	0..1		
legalAuthenticator/assignedEntity/representedOrganization/< <a href="#">Entity Identifier</a> >	A unique identifier for the scoping entity (represented organization) in this role (assignedEntity).	0..*		See common pattern: <a href="#">Entity Identifier</a> .
legalAuthenticator/assignedEntity/representedOrganization/ <b>name</b>	A non-unique textual identifier or moniker for the entity (representedOrganization).	0..*		

**Example 5.2. LegalAuthenticator XML Fragment**

<!-- This xml fragment is provided to demonstrate an example instance of each structured element in the CDA Mapping table. It is illustrative only. Logical model constraints on allowed combinations of child components are ignored in order to provide coverage of structured elements. This fragment cannot be treated as clinically valid. While the values in the fragment are conformant with the CDA Mapping table they are typically exaggerated to highlight the semantic meaning of the structured elements and may not be indicative of the expected values in a clinical document. While every effort has been taken to ensure that the examples are consistent with the message specification, where there are conflicts with the written message specification or schema, the specification or schema will take precedence. -->

```
<ClinicalDocument xmlns="urn:hl7-org:v3"
xmlns:ext="http://ns.electronichealth.net.au/Ci/Cda/Extensions/3.0"
...
>
...
<!-- Begin CDA Header -->
...
<!-- Begin legalAuthenticator -->
<legalAuthenticator>
  <time value="200910201235+1000"/>
  <signatureCode code="S"/>
  <assignedEntity>
    <id root="123F9366-78EC-11DF-861B-EE24DFD72085"/>
    <code code="253111" codeSystem="2.16.840.1.113883.13.62"
      codeSystemName="1220.0 - ANZSCO - Australian and New Zealand Standard Classification of Occupations, First Edition, Revision 1"
      displayName="General Medical Practitioner"/>
    <!-- Address -->
    <addr use="WP">
      <streetAddressLine>1 Clinician Street</streetAddressLine>
      <city>Nehtaville</city>
      <state>QLD</state>
      <postalCode>5555</postalCode>
      <additionalLocator>32568931</additionalLocator>
    </addr>
    <!-- Electronic Communication Detail -->
    <telecom use="WP" value="tel:0712341234"/>
  </assignedEntity>
  <assignedPerson>
    <!-- Person Name -->
    <name>
      <prefix>Dr.</prefix>
      <given>General</given>
      <family>Doctor</family>
    </name>
    <!-- Entity Identifier -->
    <ext:asEntityIdentifier classCode="IDENT">
      <ext:id assigningAuthorityName="HPI-I" root="1.2.36.1.2001.1003.0.800361156682112"/>
      <ext:assigningGeographicArea classCode="PLC">
        <ext:name>National Identifier</ext:name>
      </ext:assigningGeographicArea>
    </ext:asEntityIdentifier>
  </assignedPerson>
  <representedOrganization>
    <!-- Organisation Name -->
    <name>Good Health Clinic</name>
  </representedOrganization>
</legalAuthenticator>
</ClinicalDocument>
```

```
<!-- Entity Identifier -->
<ext:asEntityIdentifier classCode="IDENT">
  <ext:id assigningAuthorityName="HPI-O" root="1.2.36.1.2001.1003.0.8003621566684455"/>
  <ext:assigningGeographicArea classCode="PLC">
    <ext:name>National Identifier</ext:name>
  </ext:assigningGeographicArea>
</ext:asEntityIdentifier>
</representedOrganization>

</assignedEntity>
</legalAuthenticator>
<!-- End legalAuthenticator -->
...

<!-- End CDA Header -->

<!-- Begin CDA Body -->
<component>
  <structuredBody>
    ...

  </structuredBody>
</component>
<!-- End CDA Body -->

</ClinicalDocument>
```

## 5.1.2 Custodian

### Identification

<b>Name</b>	Custodian
<b>Definition</b>	The organization that is in charge of maintaining the document. The custodian is the steward that is entrusted with the care of the document. Every CDA document has exactly one custodian.

### Relationships

#### Parent

Name	Occurrences (child within parent)
<a href="#">ClinicalDocument</a>	1..1

## CDA R-MIM Representation

Figure 5.3 Custodian shows a subset of the CDA R-MIM containing those classes being referred to in the CDA Mapping. This data component maps to CDA Header elements.

The Custodian maps to the CDA Header element custodian. The custodian participation class represents the organisation that is in charge of maintaining the document. The role is AssignedCustodian and is represented by the CustodianOrganization entity.

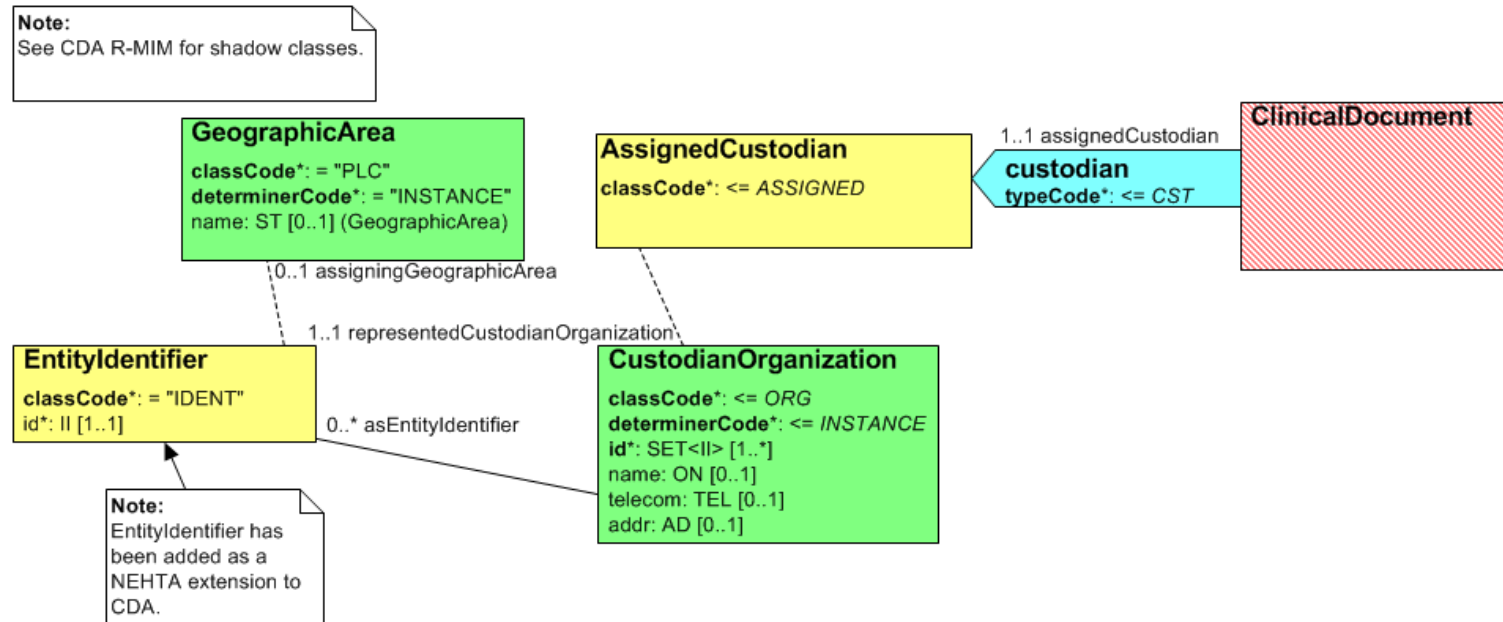

Figure 5.3. Custodian

## CDA Mapping

CDA Schema Data Element	Definition	Card	Vocab	Comments
Context: ClinicalDocument/				
<b>custodian</b>	Represents the organization that is in charge of maintaining the document. The custodian is the steward that is entrusted with the care of the document. Every CDA document has exactly one custodian.	1..1		
custodian/ <b>assignedCustodian</b>	A custodian is a scoping organization in the role of an assigned custodian.	1..1		
custodian/assignedCustodian/ <b>representedCustodianOrganization</b>	The steward organization (CustodianOrganization class) is an entity scoping the role of AssignedCustodian.	1..1		
custodian/assignedCustodian/representedCustodianOrganization/ <b>id</b>	A unique identifier for the scoping entity (representedCustodianOrganization) in this role.	1..*	UUID  This is a technical identifier that is used for system purposes such as matching. If a suitable internal key is not available, a UUID <b>MAY</b> be used.	See <id> for available attributes.
custodian/assignedCustodian/representedCustodianOrganization/< <b>Entity Identifier</b> >	The entity identifier of the custodian organization.	0..*		See common pattern: <a href="#">Entity Identifier</a> .
custodian/assignedCustodian/representedCustodianOrganization/ <b>name</b>	The name of the steward organization.	0..1		
custodian/assignedCustodian/representedCustodianOrganization/< <b>Electronic Communication Detail</b> >	The telecom of the steward organization.	0..1		See common pattern: <a href="#">Electronic Communication Detail</a> .
custodian/assignedCustodian/representedCustodianOrganization/< <b>Address</b> >	The address of the steward organization	0..1		See common pattern: <a href="#">Address</a> .

### Example 5.3. Custodian Body XML Fragment

<!-- This xml fragment is provided to demonstrate an example instance of each structured element in the CDA Mapping table. It is illustrative only. Logical model constraints on allowed combinations of child components are ignored in order to provide coverage of structured elements. This fragment cannot be treated as clinically valid. While the values in the fragment are conformant with the CDA Mapping table they are typically exaggerated to highlight the semantic meaning of the structured elements and may not be indicative of the expected values in a clinical document. While every effort has been taken to ensure that the examples are consistent with the message specification, where there are conflicts with the written message specification or schema, the specification or schema will take precedence. -->

```
<ClinicalDocument xmlns="urn:hl7-org:v3"
  xmlns:ext="http://ns.electronichealth.net.au/Ci/Cda/Extensions/3.0"
  ...
  >
  ...
  <!-- Begin CDA Header -->
  ...
  <!-- Begin Custodian -->
  <custodian>
  <assignedCustodian>
  <representedCustodianOrganization>

  <!-- ID is used for system purposes such as matching -->
  <id root="c9c04faf-d7a8-4802-8c69-980b0ce4d798" />
  <name>Custodian</name>

  <!-- Electronic Communication Detail -->
  <telecom use="WP" value="tel:0712341234" />

  <!-- Address -->
  <addr use="WP">
  <streetAddressLine>99 Clinician Street</streetAddressLine>
  <city>Nehtaville</city>
  <state>QLD</state>
  <postalCode>5555</postalCode>
  <additionalLocator>32568931</additionalLocator>
  </addr>

  <!-- Entity Identifier -->
  <ext:asEntityIdentifier classCode="IDENT">
  <ext:id assigningAuthorityName="PAI-O" root="1.2.36.1.2001.1007.1.8003640001000036" />
  <ext:assigningGeographicArea classCode="PLC">
  <ext:name>National Identifier</ext:name>
  </ext:assigningGeographicArea>
  </ext:asEntityIdentifier>

  </representedCustodianOrganization>
  </assignedCustodian>
  </custodian>
  <!-- End Custodian -->
  ...
  <!-- End CDA Header -->
  <!-- Begin CDA Body -->
  <component>
  <structuredBody>
  ...
  </structuredBody>
```



```
</component>  
<!-- End CDA Body -->  
</ClinicalDocument>
```

# 6 Context Data Specification - CDA Mapping





## 6.1 Pathology Report with Structured Clinical Content (PATHOLOGY REPORT)

### Identification

Name	Pathology Report with Structured Clinical Content (PATHOLOGY REPORT)
Metadata Type	Structured Document
Identifier	SD-32001

### Relationships

#### Children

Data Type	Name	Occurrence
	SUBJECT OF CARE	1..1
	DOCUMENT AUTHOR	1..1
	ORDER DETAILS	1..1
	REQUESTER	1..1

# CDA R-MIM Representation

Figure 6.1 CDA Header Model for Pathology Report with Structured Clinical Content Context shows a subset of the CDA R-MIM containing those classes being referred to in the CDA Mapping. This data component maps to CDA Header elements.

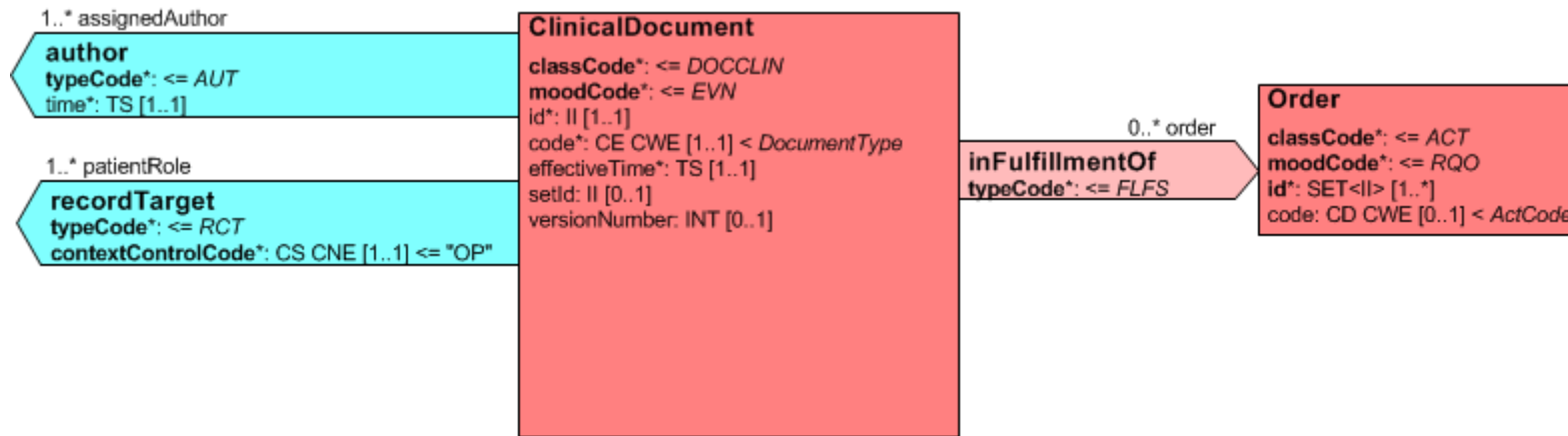

Figure 6.1. CDA Header Model for Pathology Report with Structured Clinical Content Context

## CDA Mapping

NEHTA SCS Data Component	Data Component Definition	Card	CDA Schema Data Element	Vocab	Comments
<b>CDA Header Data Elements</b>					
<b>Pathology Report with Structured Clinical Content</b>	A set of one or more results of pathology tests and their associated interpretation.	1..1	<b>ClinicalDocument</b>		
Pathology Report with Structured Clinical Content > <b>SUBJECT OF CARE</b>	Person who receives healthcare services.	1..1	See: <a href="#">SUBJECT OF CARE</a>		
Pathology Report with Structured Clinical Content > <b>DOCUMENT AUTHOR</b>	Composer of the document.	1..1	See: <a href="#">DOCUMENT AUTHOR</a>		
Pathology Report with Structured Clinical Content > <b>Document Instance Identifier</b>	A globally unique identifier for each instance of a Pathology Report document.	1..1	ClinicalDocument/id		See <id> for available attributes.
Pathology Report with Structured Clinical Content > <b>Document Type</b>	Type of document.	1..1	ClinicalDocument/code		See <code> for available attributes.
			ClinicalDocument/code/@code="100.32001"		
			ClinicalDocument/code/@codeSystem="1.2.36.1.2001.1001.101"		
			ClinicalDocument/code/@codeSystemName	The value <b>SHOULD</b> be "NCTIS Data Components". See <a href="#">CodeSystem OIDs</a> .	Optional CDA element.
			ClinicalDocument/code/@displayName="Pathology Report"		
Pathology Report with Structured Clinical Content > <b>REPORTING PATHOLOGIST</b>	Pathologist responsible for the pathology test result.	1..1	See: <a href="#">REPORTING PATHOLOGIST</a>		This logical data component could not be mapped to CDA Header elements and is instead mapped as a child of <a href="#">PATHOLOGY</a> .  A Pathology Report <b>SHALL</b> contain one instance of REPORTING PATHOLOGIST in the CONTEXT (section/author), or contain one instance of REPORTING PATHOLOGIST in each instance of Pathology Test Result (section/component/section/participant), but not both.
Pathology Report with Structured Clinical Content > <b>ORDER DETAILS</b>	Details of order that caused the creation of the document.	1..1	See: <a href="#">ORDER DETAILS</a>		

For CDA Header mappings and model which are not explicitly included in the SCS, see [ClinicalDocument](#).

**Example 6.1. Pathology Report with Structured Clinical Content Context XML Fragment**

<!-- This xml fragment is provided to demonstrate an example instance of each structured element in the CDA Mapping table. It is illustrative only. Logical model constraints on allowed combinations of child components are ignored in order to provide coverage of structured elements. This fragment cannot be treated as clinically valid. While the values in the fragment are conformant with the CDA Mapping table they are typically exaggerated to highlight the semantic meaning of the structured elements and may not be indicative of the expected values in a clinical document. While every effort has been taken to ensure that the examples are consistent with the message specification, where there are conflicts with the written message specification or schema, the specification or schema will take precedence. -->

```
<ClinicalDocument xmlns:xsi="http://www.w3.org/2001/XMLSchema-instance" xmlns="urn:hl7-org:v3"
  xmlns:xs="http://www.w3.org/2001/XMLSchema"
  xmlns:ext="http://ns.electronichealth.net.au/Ci/Cda/Extensions/3.0">
  ...
  <!-- Document Instance Identifier -->
  <id root="8f281000-498d-11e2-bcfd-0800200c9a66"/>
  <!-- Document Type -->
  <code code="100.32001"
    codeSystem="1.2.36.1.2001.1001.101"
    codeSystemName="NCTIS Data Components"
    displayName="Pathology Report"/> ...
  <!-- Begin CDA Header -->
  ...
  <!-- Begin SUBJECT OF CARE -->
  <recordTarget>
  ...
  </recordTarget>
  <!-- End SUBJECT OF CARE -->
  <!-- Begin DOCUMENT AUTHOR -->
  <author>
  ...
  </author>
  <!-- End DOCUMENT AUTHOR -->
  <!-- Begin ORDER DETAILS -->
  <inFulfillmentOf>
  ...
  </inFulfillmentOf>
  <!-- End ORDER DETAILS -->
  <!-- End CDA Header -->
  <!-- Begin CDA Body -->
  <component>
  <section>
  ...
  <!-- Begin PATHOLOGY -->
  <component>
  <section>
  ...
  <!-- Begin REPORTING PATHOLOGIST -->
  <author>
  ...
  </author>
  <!-- End REPORTING PATHOLOGIST -->
  ...
  </section>
  </component>
```

```
<!-- End PATHOLOGY -->
...
</section>
</component>
<!-- End CDA Body -->
</ClinicalDocument>
```

## 6.1.1 SUBJECT OF CARE

### Identification

Name	SUBJECT OF CARE
Metadata Type	Data Group
Identifier	DG-10296

### Relationships

#### Parent

Data Type	Name	Occurrences (child within parent)
	<a href="#">Pathology Report with Structured Clinical Content (PATHOLOGY REPORT)</a>	1..1

## CDA R-MIM Representation

Figure 6.2 SUBJECT OF CARE - Header Data Elements and Figure 6.3 SUBJECT OF CARE - Body Data Elements show a subset of the CDA R-MIM containing those classes being referred to in the CDA Mapping. This data component maps to both CDA Header and CDA Body elements.

The SUBJECT OF CARE data group maps mostly to CDA Header elements. The recordTarget participation class represents the medical record to which this document belongs. The recordTarget is associated with the Patient class by the PatientRole class. In order to represent the Date of Death of the Subject of Care, Patient.deceasedTime has been added as a NEHTA CDA extension.

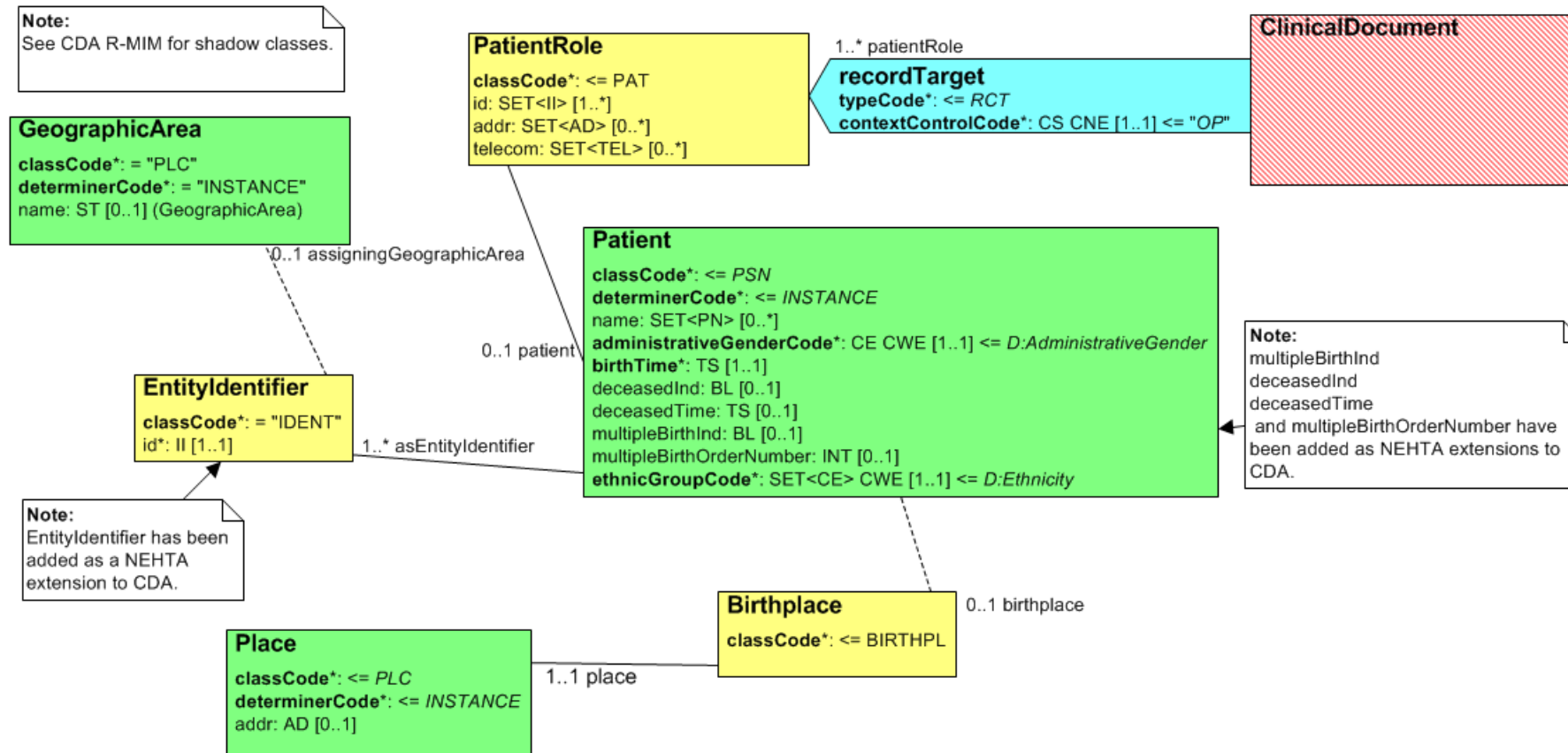

Figure 6.2. SUBJECT OF CARE - Header Data Elements





**Note**

Several data elements contained in the SUBJECT OF CARE data group could not be mapped to CDA Header elements. These data elements have been mapped to Observations in the Administrative Observations section (see [4 Administrative Observations](#) ).

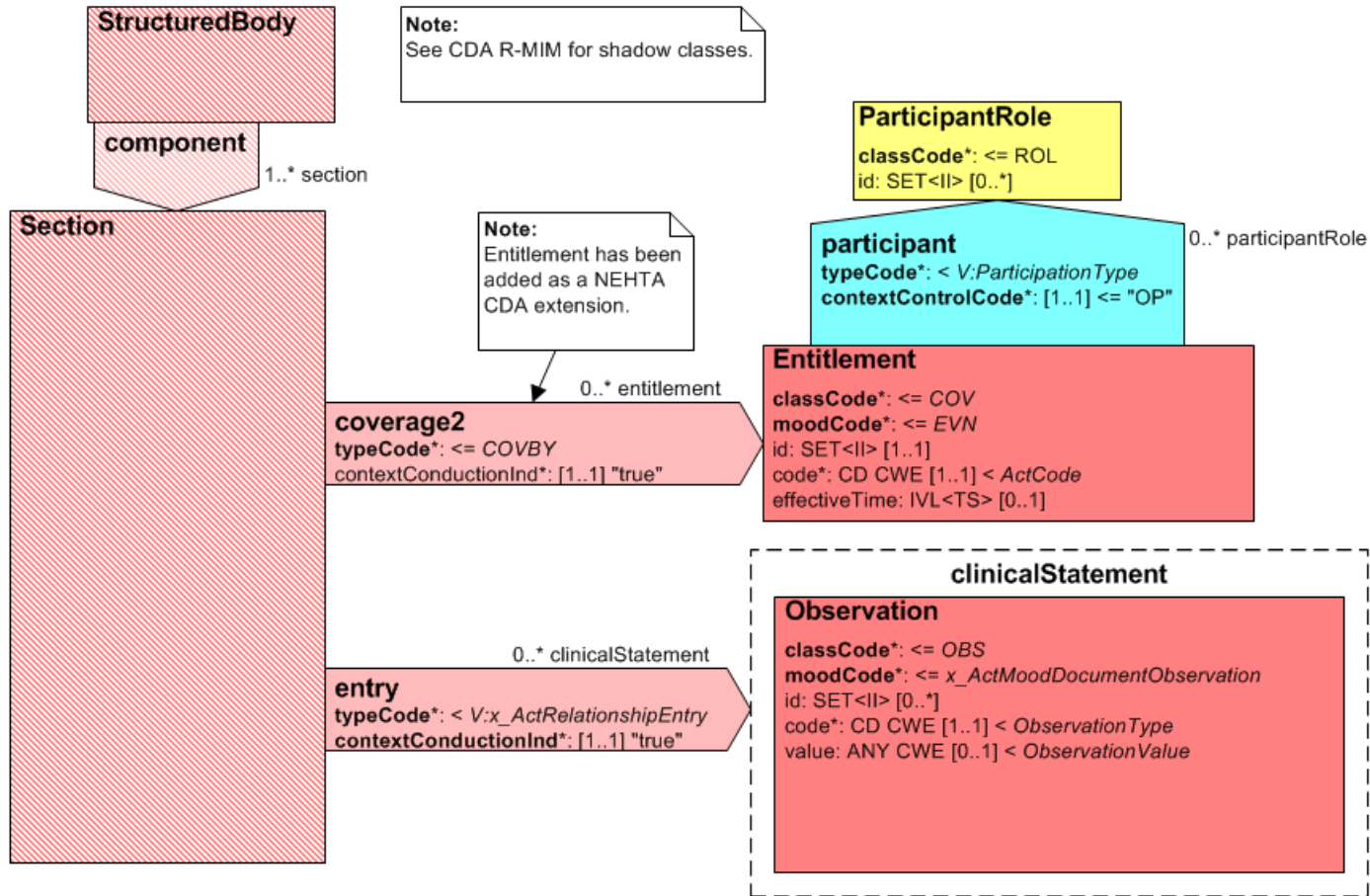

**Figure 6.3. SUBJECT OF CARE - Body Data Elements**

## CDA Mapping

NEHTA SCS Data Component	Data Component Definition	Card	CDA Schema Data Element	Vocab	Comments
<b>CDA Header Data Elements</b>			Context: ClinicalDocument/		
<b>SUBJECT OF CARE</b>	Person who receives healthcare services.	1..1	recordTarget/patientRole		
n/a	n/a	1..1	recordTarget/patientRole/id	UUID  This is a technical identifier that is used for system purposes such as matching. If a suitable internal key is not available, a UUID <b>MAY</b> be used.	Required CDA element.
<b>SUBJECT OF CARE &gt; Participation Type</b>	The categorisation of the nature of the participant's involvement in the healthcare event described by this participation.	1..1	n/a	Participation Type <b>SHALL</b> have an implementation-specific value equivalent to "Subject of Care".	Not mapped directly, encompassed implicitly in recordTarget/typeCode = "RCT" (optional, fixed value).
<b>SUBJECT OF CARE &gt; Role</b>	The involvement or role of the participant in the related action from a healthcare perspective rather than the specific participation perspective.	1..1	n/a	Role <b>SHALL</b> have an implementation-specific value equivalent to "Patient".	Not mapped directly, encompassed implicitly in recordTarget/patientRole/classCode = "PAT".
<b>SUBJECT OF CARE &gt; Participant</b>	Details pertinent to the identification of an individual or organisation or device that has participated in a healthcare event/encounter/clinical interaction.	1..1	recordTarget/patientRole/patient		
<b>SUBJECT OF CARE &gt; Participant &gt; Entity Identifier</b>	A number or code issued for the purpose of identifying a participant within a healthcare context.	1..*	recordTarget/patientRole/patient/<Entity Identifier>	The value of one Entity Identifier <b>SHALL</b> be an Australian IHI.	See common pattern: <a href="#">Entity Identifier</a> .  The Subject of Care's Medicare card number is recorded in Entitlement, not Entity Identifier.
<b>SUBJECT OF CARE &gt; Participant &gt; Address</b>	The description of a location where an entity is located or can be otherwise reached or found and a description of the purpose for which that address is primarily used by that entity.	1..*	recordTarget/patientRole/<Address>		See common pattern: <a href="#">Address</a> .
<b>SUBJECT OF CARE &gt; Participant &gt; Electronic Communication Detail</b>	The electronic communication details of entities.	0..*	recordTarget/patientRole/<Electronic Communication Detail>		See common pattern: <a href="#">Electronic Communication Detail</a> .

NEHTA SCS Data Component	Data Component Definition	Card	CDA Schema Data Element	Vocab	Comments
SUBJECT OF CARE > Participant > <b>Person or Organisation or Device</b>	Represents a choice to be made at run-time between PERSON, ORGANISATION or DEVICE.	1..1	n/a	PERSON OR ORGANISATION OR DEVICE <b>SHALL</b> be instantiated as a PERSON.	This logical NEHTA data component has no mapping to CDA.  The cardinality of this component propagates to its children.
SUBJECT OF CARE > Participant > Person or Organisation or Device > <b>Person</b>	An individual who is in the role of healthcare provider, who uses or is a potential user of a healthcare service, or is in some way related to, or a representative of, a subject of care (patient).	1..1	n/a		Not mapped directly, encompassed implicitly in recordTarget/patientRole/ patient.
SUBJECT OF CARE > Participant > Person or Organisation or Device > Person > <b>Person Name</b>	The appellation by which an individual may be identified separately from any other within a social context.	1..*	recordTarget/patientRole/patient/ <Person Name>		See common pattern: <a href="#">Person Name</a> .
SUBJECT OF CARE > Participant > Person or Organisation or Device > Person > <b>Demographic Data</b>	Additional characteristics of a person that may be useful for identification or other clinical purposes.	1..1	n/a		This logical NEHTA data component has no mapping to CDA.  The cardinality of this component propagates to its children.
SUBJECT OF CARE > Participant > Person or Organisation or Device > Person > Demographic Data > <b>Sex</b>	The biological distinction between male and female. Where there is inconsistency between anatomical and chromosomal characteristics, sex is based on anatomical characteristics.	1..1	recordTarget/patientRole/patient/ <b>administrativeGenderCode</b>	<a href="#">AS 5017-2006 Health Care Client Identifier Sex</a>	
SUBJECT OF CARE > Participant > Person or Organisation or Device > Person > Demographic Data > <b>Date of Birth Detail</b>	Details of the accuracy, origin and value of a person's date of birth.	1..1	n/a		This logical NEHTA data component has no mapping to CDA.  The cardinality of this component propagates to its children.
SUBJECT OF CARE > Participant > Person or Organisation or Device > Person > Demographic Data > Date of Birth Detail > <b>Date of Birth</b>	The date of birth of the person.	1..1	recordTarget/patientRole/patient/ <b>birthTime</b>		See <time> for available attributes.

NEHTA SCS Data Component	Data Component Definition	Card	CDA Schema Data Element	Vocab	Comments
<b>CDA Body Level 3 Data Elements</b>					
			Context: ClinicalDocument/component/structuredBody/component[admin_obs]/section/ (See <a href="#">4 Administrative Observations</a> )		
SUBJECT OF CARE > Participant > Person or Organisation or Device > Person > Demographic Data > Date of Birth Detail > <b>Date of Birth is Calculated From Age</b>	Indicates whether or not a person's date of birth has been derived from the value in the Age data element.	0..1	<b>entry[calc_age]</b>		
			entry[calc_age]/ <b>observation</b>		
			entry[calc_age]/observation/ <b>@classCode="OBS"</b>		
			entry[calc_age]/observation/ <b>@moodCode="EVN"</b>		
			entry[calc_age]/observation/ <b>code</b>		
			entry[calc_age]/observation/code/ <b>@code="103.16233"</b>		
			entry[calc_age]/observation/code/ <b>@codeSystem="1.2.36.1.2001.1001.101"</b>		
			entry[calc_age]/observation/code/ <b>@codeSystemName</b>	The value <b>SHOULD</b> be "NCTIS Data Components".  See <a href="#">CodeSystem OIDs</a> .	Optional CDA element.
			entry[calc_age]/observation/code/ <b>@displayName="Date of Birth is Calculated From Age"</b>		
			entry[calc_age]/observation/ <b>id</b>	UUID  This is a technical identifier that is used for system purposes such as matching. If a suitable internal key is not available, a UUID <b>MAY</b> be used.	See <id> for available attributes.
entry[calc_age]/observation/ <b>value:BL</b>		If the date of birth has been calculated from the age this is true, otherwise it is false.			

NEHTA SCS Data Component	Data Component Definition	Card	CDA Schema Data Element	Vocab	Comments
SUBJECT OF CARE > Participant > Person or Organisation or Device > Person > Demographic Data > Date of Birth Detail > <b>Date of Birth Accuracy Indicator</b>	The level of certainty or estimation of a person's date of birth.	0..1	<b>entry[dob_acc]</b>		
			entry[dob_acc]/ <b>observation</b>		
			entry[dob_acc]/observation/@ <b>classCode</b> ="OBS"		
			entry[dob_acc]/observation/@ <b>moodCode</b> ="EVN"		
			entry[dob_acc]/observation/ <b>code</b>		
			entry[dob_acc]/observation/code/@ <b>code</b> ="102.16234"		
			entry[dob_acc]/observation/code/@ <b>codeSystem</b> ="1.2.36.1.2001.1001.101"		
			entry[dob_acc]/observation/code/@ <b>codeSystemName</b>	The value <b>SHOULD</b> be "NCTIS Data Components".  See <a href="#">CodeSystem OIDs</a> .	Optional CDA element.
entry[dob_acc]/observation/code/@ <b>displayName</b> ="Date of Birth Accuracy Indicator"					
entry[dob_acc]/observation/ <b>id</b>	UUID  This is a technical identifier that is used for system purposes such as matching. If a suitable internal key is not available, a UUID <b>MAY</b> be used.	See <id> for available attributes.			
entry[dob_acc]/observation/ <b>value:CS</b>	<a href="#">AS 5017-2006 Health Care Client Identifier Date Accuracy Indicator</a>				
SUBJECT OF CARE > Participant > Person or Organisation or Device > Person > Demographic Data > Date of Birth Detail > Date of Birth Accuracy Indicator > <b>Date of Birth Day Accuracy Indicator</b>	The accuracy of the day component of a person's date of birth.	1..1	n/a		Encompassed in the mapping for Date of Birth Accuracy Indicator (above).
SUBJECT OF CARE > Participant > Person or Organisation or Device > Person > Demographic Data > Date of Birth Detail > Date of Birth Accuracy Indicator > <b>Date of Birth Month Accuracy Indicator</b>	The accuracy of the month component of a person's date of birth.	1..1	n/a		Encompassed in the mapping for Date of Birth Accuracy Indicator (above).

NEHTA SCS Data Component	Data Component Definition	Card	CDA Schema Data Element	Vocab	Comments
SUBJECT OF CARE > Participant > Person or Organisation or Device > Person > Demographic Data > Date of Birth Detail > Date of Birth Accuracy Indicator > <b>Date of Birth Year Accuracy Indicator</b>	The accuracy of the year component of a person's date of birth.	1..1	n/a		Encompassed in the mapping for Date of Birth Accuracy Indicator (above).
SUBJECT OF CARE > Participant > Person or Organisation or Device > Person > Demographic Data > <b>Age Detail</b>	Details of the accuracy and value of a person's age.	0..1	n/a		This logical NEHTA data component has no mapping to CDA.  The cardinality of this component propagates to its children.
SUBJECT OF CARE > Participant > Person or Organisation or Device > Person > Demographic Data > Age Detail > <b>Age</b>	The age of a person/subject of care at the time.	1..1	<b>entry[age]</b>		
			entry[age]/ <b>observation</b>		
			entry[age]/observation/@ <b>classCode</b> ="OBS"		
			entry[age]/observation/@ <b>moodCode</b> ="EVN"		
			entry[age]/observation/ <b>code</b>		
			entry[age]/observation/code/@ <b>code</b> ="103.20109"		
			entry[age]/observation/code/@ <b>codeSystem</b> ="1.2.36.1.2001.1001.101"		
			entry[age]/observation/code/@ <b>codeSystemName</b>	The value <b>SHOULD</b> be "NCTIS Data Components".  See <a href="#">CodeSystem OIDs</a> .	Optional CDA element.
			entry[age]/observation/code/@ <b>displayName</b> ="Age"		
entry[age]/observation/ <b>id</b>	UUID  This is a technical identifier that is used for system purposes such as matching. If a suitable internal key is not available, a UUID <b>MAY</b> be used.	See <id> for available attributes.			
entry[age]/observation/ <b>value:PQ</b>					

NEHTA SCS Data Component	Data Component Definition	Card	CDA Schema Data Element	Vocab	Comments
SUBJECT OF CARE > Participant > Person or Organisation or Device > Person > Demographic Data > Age Detail > <b>Age Accuracy Indicator</b>	The accuracy of a person's age.	0..1	<b>entry[age_acc]</b>		
			entry[age_acc]/ <b>observation</b>		
			entry[age_acc]/observation/@ <b>classCode="OBS"</b>		
			entry[age_acc]/observation/@ <b>moodCode="EVN"</b>		
			entry[age_acc]/observation/ <b>code</b>		
			entry[age_acc]/observation/code/@ <b>code="103.16279"</b>		
			entry[age_acc]/observation/code/@ <b>codeSystem="1.2.36.1.2001.1001.101"</b>		
			entry[age_acc]/observation/code/@ <b>codeSystemName</b>	The value <b>SHOULD</b> be "NCTIS Data Components".  See <a href="#">CodeSystem OIDs</a> .	Optional CDA element.
			entry[age_acc]/observation/code/@ <b>displayName="Age Accuracy Indicator"</b>		
entry[age_acc]/observation/ <b>id</b>	UUID  This is a technical identifier that is used for system purposes such as matching. If a suitable internal key is not available, a UUID <b>MAY</b> be used.	See <id> for available attributes.			
entry[age_acc]/observation/ <b>value:BL</b>		If the age is considered to be accurate, this is true, otherwise it is false.			

NEHTA SCS Data Component	Data Component Definition	Card	CDA Schema Data Element	Vocab	Comments
SUBJECT OF CARE > Participant > Person or Organisation or Device > Person > Demographic Data > <b>Birth Plurality</b>	An indicator of multiple birth, showing the total number of births resulting from a single pregnancy.	0..1	<b>entry[brth_plr]</b>		
			entry[brth_plr]/ <b>observation</b>		
			entry[brth_plr]/observation/@classCode="OBS"		
			entry[brth_plr]/observation/@moodCode="EVN"		
			entry[brth_plr]/observation/code		
			entry[brth_plr]/observation/code/@code="103.16249"		
			entry[brth_plr]/observation/code/@codeSystem="1.2.36.1.2001.1001.101"		
			entry[brth_plr]/observation/code/@codeSystemName	The value <b>SHOULD</b> be "NCTIS Data Components".  See <a href="#">CodeSystem OIDs</a> .	Optional CDA element.
			entry[brth_plr]/observation/code/@displayName="Birth Plurality"		
			entry[brth_plr]/observation/id	UUID  This is a technical identifier that is used for system purposes such as matching. If a suitable internal key is not available, a UUID <b>MAY</b> be used.	See <id> for available attributes.
entry[brth_plr]/observation/value:INT					
<b>CDA Header Data Elements</b>			Context: ClinicalDocument/		
SUBJECT OF CARE > Participant > Person or Organisation or Device > Person > Demographic Data > <b>Birth Order</b>	The sequential order of each baby of a multiple birth regardless of live or still birth.	0..1	recordTarget/patientRole/patient/ext:multipleBirthInd		See NEHTA CDA extension: <a href="#">Multiple Birth</a> .
			recordTarget/patientRole/patient/ext:multipleBirthOrderNumber		
SUBJECT OF CARE > Participant > Person or Organisation or Device > Person > Demographic Data > <b>Date of Death Detail</b>	Details of the accuracy and value of a person's date of death.	0..1	n/a		This logical NEHTA data component has no mapping to CDA.  The cardinality of this component propagates to its children.



NEHTA SCS Data Component	Data Component Definition	Card	CDA Schema Data Element	Vocab	Comments
SUBJECT OF CARE > Participant > Person or Organisation or Device > Person > Demographic Data > Date of Death Detail > <b>Date of Death</b>	The date or date and time at which a person was estimated or certified to have died.	1..1	recordTarget/patientRole/patient/ext: <b>deceasedInd</b>		See NEHTA CDA extension: <a href="#">Deceased Time</a> .
			recordTarget/patientRole/patient/ext: <b>deceasedTime</b>		See <time> for available attributes.
<b>CDA Body Level 3 Data Elements</b>			Context: ClinicalDocument/component/structuredBody/component[admin_obs]/section/ (See <a href="#">4 Administrative Observations</a> )		
SUBJECT OF CARE > Participant > Person or Organisation or Device > Person > Demographic Data > Date of Death Detail > <b>Date of Death Accuracy Indicator</b>	The level of certainty or estimation of a person's date of death.	0..1	<b>entry[dod_acc]</b>		This logical NEHTA data component has no mapping to CDA.  The cardinality of this component propagates to its children.
			entry[dod_acc]/ <b>observation</b>		
			entry[dod_acc]/observation/@ <b>classCode</b> ="OBS"		
			entry[dod_acc]/observation/@ <b>moodCode</b> ="EVN"		
			entry[dod_acc]/observation/ <b>code</b>		
			entry[dod_acc]/observation/code/@ <b>code</b> ="102.16252"		
			entry[dod_acc]/observation/code/@ <b>codeSystem</b> ="1.2.36.1.2001.1001.101"		
			entry[dod_acc]/observation/code/@ <b>codeSystemName</b>	The value <b>SHOULD</b> be "NCTIS Data Components".  See <a href="#">CodeSystem OIDs</a> .	Optional CDA element.
			entry[dod_acc]/observation/code/@ <b>displayName</b> ="Date of Death Accuracy Indicator"		
			entry[dod_acc]/observation/ <b>id</b>	UUID  This is a technical identifier that is used for system purposes such as matching. If a suitable internal key is not available, a UUID <b>MAY</b> be used.	See <id> for available attributes.
entry[doc_acc]/observation/ <b>value:CS</b>	<a href="#">AS 5017-2006 Health Care Client Identifier Date Accuracy Indicator</a>				

NEHTA SCS Data Component	Data Component Definition	Card	CDA Schema Data Element	Vocab	Comments
SUBJECT OF CARE > Participant > Person or Organisation or Device > Person > Demographic Data > Date of Death Detail > Date of Death Accuracy Indicator > <b>Date of Death Day Accuracy Indicator</b>	The accuracy of the day component of a person's date of death.	1..1	n/a		Encompassed in the mapping for Date of Death Accuracy Indicator (above).
SUBJECT OF CARE > Participant > Person or Organisation or Device > Person > Demographic Data > Date of Death Detail > Date of Death Accuracy Indicator > <b>Date of Death Month Accuracy Indicator</b>	The accuracy of the month component of a person's date of death.	1..1	n/a		Encompassed in the mapping for Date of Death Accuracy Indicator (above).
SUBJECT OF CARE > Participant > Person or Organisation or Device > Person > Demographic Data > Date of Death Detail > Date of Death Accuracy Indicator > <b>Date of Death Year Accuracy Indicator</b>	The accuracy of the year component of a person's date of death.	1..1	n/a		Encompassed in the mapping for Date of Death Accuracy Indicator (above).

NEHTA SCS Data Component	Data Component Definition	Card	CDA Schema Data Element	Vocab	Comments
SUBJECT OF CARE > Participant > Person or Organisation or Device > Person > Demographic Data > <b>Source of Death Notification</b>	The person, location, organisation or other originator of information relating to the date of death.	0..1	<b>entry[src_notif]</b>		
			entry[src_notif]/ <b>observation</b>		
			entry[src_notif]/observation/@ <b>classCode</b> ="OBS"		
			entry[src_notif]/observation/@ <b>moodCode</b> ="EVN"		
			entry[src_notif]/observation/ <b>code</b>		
			entry[src_notif]/observation/code/@ <b>code</b> ="103.10243"		
			entry[src_notif]/observation/code/@ <b>codeSystem</b> ="1.2.36.1.2001.1001.101"		
			entry[src_notif]/observation/code/@ <b>codeSystemName</b>	The value <b>SHOULD</b> be "NCTIS Data Components".  See <a href="#">CodeSystem OIDs</a> .	Optional CDA element.
			entry[src_notif]/observation/code/@ <b>displayName</b> ="Source of Death Notification"		
entry[src_notif]/observation/ <b>id</b>	UUID  This is a technical identifier that is used for system purposes such as matching. If a suitable internal key is not available, a UUID <b>MAY</b> be used.	See <id> for available attributes.			
entry[src_notif]/observation/ <b>value:CD</b>	<a href="#">AS 5017-2006: Health Care Client Source of Death Notification</a>	See <code> for available attributes.			

NEHTA SCS Data Component	Data Component Definition	Card	CDA Schema Data Element	Vocab	Comments
SUBJECT OF CARE > Participant > Person or Organisation or Device > Person > Demographic Data > <b>Mother's Original Family Name</b>	The original family name of the person's mother.	0..1	<b>entry[mothers_name]</b>		
			entry[mothers_name]/observation		
			entry[mothers_name]/observation/@classCode="OBS"		
			entry[mothers_name]/observation/@moodCode="EVN"		
			entry[mothers_name]/observation/code		
			entry[mothers_name]/observation/code/@code="103.10245"		
			entry[mothers_name]/observation/code/@codeSystem="1.2.36.1.2001.1001.101"		
			entry[mothers_name]/observation/code/@codeSystemName	The value <b>SHOULD</b> be "NCTIS Data Components".  See <a href="#">CodeSystem OIDs</a> .	Optional CDA element.
			entry[mothers_name]/observation/code/@displayName="Mother's Original Family Name"		
			entry[mothers_name]/observation/id	UUID  This is a technical identifier that is used for system purposes such as matching. If a suitable internal key is not available, a UUID <b>MAY</b> be used.	See <id> for available attributes.
			entry[mothers_name]/observation/value:PN		
<b>CDA Header Data Elements</b>			Context: ClinicalDocument/		
SUBJECT OF CARE > Participant > Person or Organisation or Device > Person > Demographic Data > <b>Country of Birth</b>	The country in which the person was born.	0..1	recordTarget/patientRole/patient/ <b>birthplace/place/addr/country</b>	<a href="#">Standard Australian Classification of Countries (SACC) Cat. No. 1269 [ABS2008]</a>	Use the name, not the numbered code.
SUBJECT OF CARE > Participant > Person or Organisation or Device > Person > Demographic Data > <b>State/Territory of Birth</b>	The identifier of the Australian state or territory where a person is born.	0..1	recordTarget/patientRole/patient/ <b>birthplace/place/addr/state</b>	<a href="#">AS 5017-2006 Australian State/Territory Identifier - Postal</a>	
SUBJECT OF CARE > Participant > Person or Organisation or Device > Person > Demographic Data > <b>Indigenous Status</b>	Indigenous Status is a measure of whether a person identifies as being of Aboriginal or Torres Strait Islander origin.	1..1	recordTarget/patientRole/patient/ <b>ethnicGroupCode</b>	<a href="#">METeOR 291036: Indigenous Status</a>	

NEHTA SCS Data Component	Data Component Definition	Card	CDA Schema Data Element	Vocab	Comments
<b>CDA Body Level 3 Data Elements</b>			Context: ClinicalDocument/component/structuredBody/component[admin_obs]/section/		
SUBJECT OF CARE > Participant > <b>Entitlement</b>	The entitlement or right of a participant to act in a given capacity (as defined by Entitlement Type) within a healthcare context.	0..*	<b>ext:coverage2/@typeCode="COVBY"</b>		See NEHTA CDA extension: <a href="#">Entitlement</a> .
			ext:coverage2/ext:entitlement		
			ext:coverage2/ext:entitlement/@classCode="COV"		
			ext:coverage2/ext:entitlement/@moodCode="EVN"		
			ext:coverage2/ext:entitlement/ext:participant/@typeCode="BEN"		
			ext:coverage2/ext:entitlement/ext:participant/ext:participantRole/@classCode="PAT"		
			ext:coverage2/ext:entitlement/ext:participant/ext:participantRole/ext:id	UUID This is a technical identifier that is used for system purposes such as matching. If a suitable internal key is not available, a UUID <b>MAY</b> be used.	<b>SHALL</b> hold the same value as ClinicalDocument/recordTarget/patientRole/id.
SUBJECT OF CARE > Participant > Entitlement > <b>Entitlement Number</b>	A number or code issued for the purpose of identifying the entitlement or right of a participant to act in a given capacity (as defined by Entitlement Type) within a healthcare context.	1..1	ext:coverage2/ext:entitlement/ext:id		
SUBJECT OF CARE > Participant > Entitlement > <b>Entitlement Type</b>	The description of the scope of an entitlement.	1..1	ext:coverage2/ext:entitlement/ext:code	NCTIS: <a href="#">Admin Codes - Entitlement Type</a>	See <code> for available attributes.
SUBJECT OF CARE > Participant > Entitlement > <b>Entitlement Validity Duration</b>	The time interval for which an entitlement is valid.	0..1	ext:coverage2/ext:entitlement/ext:effectiveTime		See <time> for available attributes.

## Example 6.2. SUBJECT OF CARE XML Fragment

<!-- This xml fragment is provided to demonstrate an example instance of each structured element in the CDA Mapping table. It is illustrative only. Logical model constraints on allowed combinations of child components are ignored in order to provide coverage of structured elements. This fragment cannot be treated as clinically valid. While the values in the fragment are conformant with the CDA Mapping table they are typically exaggerated to highlight the semantic meaning of the structured elements and may not be indicative of the expected values in a clinical document. While every effort has been taken to ensure that the examples are consistent with the message specification, where there are conflicts with the written message specification or schema, the specification or schema will take precedence. -->

```
<ClinicalDocument
  xmlns="urn:h17-org:v3"
  xmlns:ext="http://ns.electronichealth.net.au/Ci/Cda/Extensions/3.0"
  ...
  >
  ...

  <!-- Begin SUBJECT OF CARE - Header Part -->
  <recordTarget typeCode="RCT">
  <patientRole classCode="PAT">
  <!-- This system generated id is used for matching patient Entitlement -->
  <id root="7AA0BAAC-0CD0-11E0-9516-4350DFD72085"/>

  <!-- Address -->
  <addr use="H">
  <streetAddressLine>1 Patient Street</streetAddressLine>
  <city>Nehtaville</city>
  <state>QLD</state>
  <postalCode>5555</postalCode>
  <additionalLocator>32568931</additionalLocator>
  <country>Australia</country>
  </addr>

  <!-- Electronic Communication Detail -->
  <telecom use="H" value="tel:0499999999"/>

  <!-- Participant -->
  <patient>

  <!-- Person Name -->
  <name use="L">
  <prefix>Ms</prefix>
  <given>Sally</given>
  <family>Grant</family>
  </name>

  <!-- Sex -->
  <administrativeGenderCode code="F"
  codeSystem="2.16.840.1.113883.13.68"
  codeSystemName="AS 5017-2006 Health Care Client Sex"
  displayName="Female" />

  <!-- Date of Birth -->
  <birthTime value="20110712"/>

  <!-- Indigenous Status -->
  <ethnicGroupCode code="4" codeSystem="2.16.840.1.113883.3.879.291036" codeSystemName="METeOR Indigenous Status"
  displayName="Neither Aboriginal nor Torres Strait Islander origin" />

  <!-- Multiple Birth Indicator -->
  <ext:multipleBirthInd value="true"/>
  <ext:multipleBirthOrderNumber value="2"/>
```

```

<!-- Date of Death -->
<ext:deceasedInd value="true"/>
<ext:deceasedTime value="20121112"/>

<!-- Country of Birth/State of Birth -->
<birthplace>
  <place>
    <addr>
      <country>Australia</country>
      <state>QLD</state>
    </addr>
  </place>
</birthplace>

<!-- Entity Identifier -->
<ext:asEntityIdentifier classCode="IDENT">
  <ext:id assigningAuthorityName="IHI" root="1.2.36.1.2001.1003.0.8003608833357361"/>
  <ext:assigningGeographicArea classCode="PLC">
    <ext:name>National Identifier</ext:name>
  </ext:assigningGeographicArea>
</ext:asEntityIdentifier>
</patient>
</patientRole>
</recordTarget>
<!-- End SUBJECT OF CARE - Header Part -->
...

<!-- Begin CDA Body -->
<component>
  <structuredBody>
    ...

    <!-- Begin Section Administrative Observations -->
  <component><!-- [admin_obs] -->
  <section>
    <code code="102.16080"
      codeSystem="1.2.36.1.2001.1001.101"
      codeSystemName="NCTIS Data Components"
      displayName="Administrative Observations"/>

    <title>Administrative Observations</title>

    <!-- Narrative text -->
    <text>
    <table>
      <tbody>
        <tr>
          <th>Date of Birth is Calculated From Age</th>
          <td>True</td>
        </tr>
        <tr>
          <th>Date of Birth Accuracy Indicator</th>
          <td>AAA</td>
        </tr>
        <tr>
          <th>Age</th>
          <td>1</td>
        </tr>
        <tr>
          <th>Age Accuracy Indicator</th>
          <td>True</td>
        </tr>
      </tbody>
    </table>
  </text>
  </component>
  </structuredBody>
</component>

```

```
<tr>
  <th>Birth Plurality</th>
  <td>3</td>
</tr>
<tr>
  <th>Source of Death Notification</th>
  <td>Relative</td>
</tr>
<tr>
  <th>Mother's Maiden Name</th>
  <td>Smith</td>
</tr>
<tr>
  <th>Australian Medicare Card Number</th>
  <td>2296818481</td>
</tr>
...
</tbody>
</table>
</text>

<!-- Begin SUBJECT OF CARE - Body -->
<!-- Begin Date of Birth is Calculated From Age -->
<entry><!-- [calc_age] -->
<observation classCode="OBS" moodCode="EVN">
  <id root="DA10C13E-EFD0-11DF-91AF-B5CCDFD72085"/>
  <code code="103.16233"
    codeSystem="1.2.36.1.2001.1001.101"
    codeSystemName="NCTIS Data Components"
    displayName="Date of Birth is Calculated From Age"/>
  <value value="true" xsi:type="BL"/>
</observation>
</entry><!-- [calc_age] -->
<!-- End Date of Birth is Calculated From Age -->

<!-- Begin Date of Birth Accuracy Indicator-->
<entry><!-- [dob_acc] -->
<observation classCode="OBS" moodCode="EVN">
  <id root="D253216C-EFD0-11DF-A686-ADCCDFD72085"/>
  <code code="102.16234"
    codeSystem="1.2.36.1.2001.1001.101"
    codeSystemName="NCTIS Data Components"
    displayName="Date of Birth Accuracy Indicator"/>
  <value code="AAA" xsi:type="CS"/>
</observation>
</entry><!-- [dob_acc] -->
<!-- End Date of Birth Accuracy Indicator-->

<!-- Begin Age -->
<entry><!-- [age] -->
<observation classCode="OBS" moodCode="EVN">
  <id root="CCF0D55C-EFD0-11DF-BEA2-A6CCDFD72085"/>
  <code code="103.20109"
    codeSystem="1.2.36.1.2001.1001.101"
    codeSystemName="NCTIS Data Components"
    displayName="Age"/>
  <value xsi:type="PQ" value="1" unit="a"/>
</observation>
</entry><!-- [age] -->
<!-- End Age -->
```



```

<!-- Age Accuracy Indicator -->
<entry><!-- [age_acc] -->
<observation classCode="OBS" moodCode="EVN">
  <id root="C629C9F4-EFD0-11DF-AA9E-96CCDFD72085" />
  <code code="103.16279"
    codeSystem="1.2.36.1.2001.1001.101"
    codeSystemName="NCTIS Data Components"
    displayName="Age Accuracy Indicator" />
  <value value="true" xsi:type="BL" />
</observation>
</entry><!-- [age_acc] -->

<!-- Birth Plurality -->
<entry><!-- [birth_plr] -->
<observation classCode="OBS" moodCode="EVN">
  <id root="C1EE2646-EFD0-11DF-8D9C-95CCDFD72085" />
  <code code="103.16249"
    codeSystem="1.2.36.1.2001.1001.101"
    codeSystemName="NCTIS Data Components"
    displayName="Birth Plurality" />
  <value value="3" xsi:type="INT" />
</observation>
</entry><!-- [birth_plr] -->

<!-- Begin Source of Death Notification-->
<entry>
<!-- [src_notif] -->
<observation classCode="OBS" moodCode="EVN">

  <!-- ID is used for system purposes such as matching -->
  <id root="C749A146-2789-11E1-90AC-74064824019B" />
  <code code="103.10243" codeSystem="1.2.36.1.2001.1001.101" codeSystemName="NCTIS Data Components"
    displayName="Source of Death Notification" />
  <value code="R" codeSystem="2.16.840.1.113883.13.64"
    codeSystemName="AS 5017-2006 Health Care Client Source of Death Notification" displayName="Relative"
    xsi:type="CD" />
</observation>
</entry>
<!-- [src_notif] -->
<!-- End Source of Death Notification-->

<!-- Begin Mother's Original Family Name -->
<entry>
<!-- [mothers_name] -->
<observation classCode="OBS" moodCode="EVN">

  <!-- ID is used for system purposes such as matching -->
  <id root="E432CD48-278C-11E1-BDA1-0F0A4824019B" />
  <code code="103.10245" codeSystem="1.2.36.1.2001.1001.101" codeSystemName="NCTIS Data Components"
    displayName="Mother's Original Family Name" />
  <value xsi:type="PN">
    <family>Smith</family>
  </value>
</observation>
</entry>
<!-- [mothers_name] -->
<!-- End Mother's Original Family Name -->

<!-- Begin Date of Death Accuracy Indicator-->
<entry>
<!-- [dod_acc] -->
<observation classCode="OBS" moodCode="EVN">

```

```
<!-- ID is used for system purposes such as matching -->
<id root="D253216C-EFD0-11DF-A686-ADCCDFD72085" />
<code code="102.16252" codeSystem="1.2.36.1.2001.1001.101" codeSystemName="NCTIS Data Components"
  displayName="Date of Death Accuracy Indicator" />
<value code="AAA" xsi:type="CS" />
</observation>
</entry>
<!-- [dod_acc] -->
<!-- End Date of Death Accuracy Indicator-->

<!-- Begin Entitlement -->
<ext:coverage2 typeCode="COVBY">
<ext:entitlement classCode="COV" moodCode="EVN">
  <ext:id assigningAuthorityName="Medicare Card Number" root="1.2.36.1.5001.1.0.7.1" extension="2296818481" />
  <ext:code code="1" codeSystem="1.2.36.1.2001.1001.101.104.16047" codeSystemName="NCTIS Entitlement Type Values" displayName="Medicare Benefits"/>
  <ext:effectiveTime>
    <high value="20110101"/>
  </ext:effectiveTime>
  <ext:participant typeCode="BEN">
    <ext:participantRole classCode="PAT">
      <ext:id root="7AA0BAAC-0CD0-11E0-9516-4350DFD72085" />
    </ext:participantRole>
  </ext:participant>
</ext:entitlement>
</ext:coverage2>
<!-- End Entitlement -->

<!-- End SUBJECT OF CARE - Body -->
...

</section>
</component>
<!-- End Section Administrative Observations -->
...

</structuredBody>
</component>
<!-- End CDA Body -->
</ClinicalDocument>
```

## 6.1.2 DOCUMENT AUTHOR

### Identification

Name	DOCUMENT AUTHOR
Metadata Type	Data Group
Identifier	DG-10296

### Relationships

#### Parent

Data Type	Name	Occurrences (child within parent)
	<a href="#">Pathology Report with Structured Clinical Content (PATHOLOGY REPORT)</a>	1..1

## CDA R-MIM Representation

Figure 6.4 DOCUMENT AUTHOR shows a subset of the CDA R-MIM containing those classes being referred to in the CDA Mapping. This data component maps to CDA Header elements.

The DOCUMENT AUTHOR data group instantiated as PERSON (Healthcare Provider) is related to its context of ClinicalDocument by the author participation class. An author is a person in the role of assignedAuthor (AssignedAuthor class). The entity playing the role is assignedAuthorChoice (Person class). The entity identifier of the participant is mapped to the EntityIdentifier class (NEHTA CDA extension) and is associated to the assignedAuthorChoice.

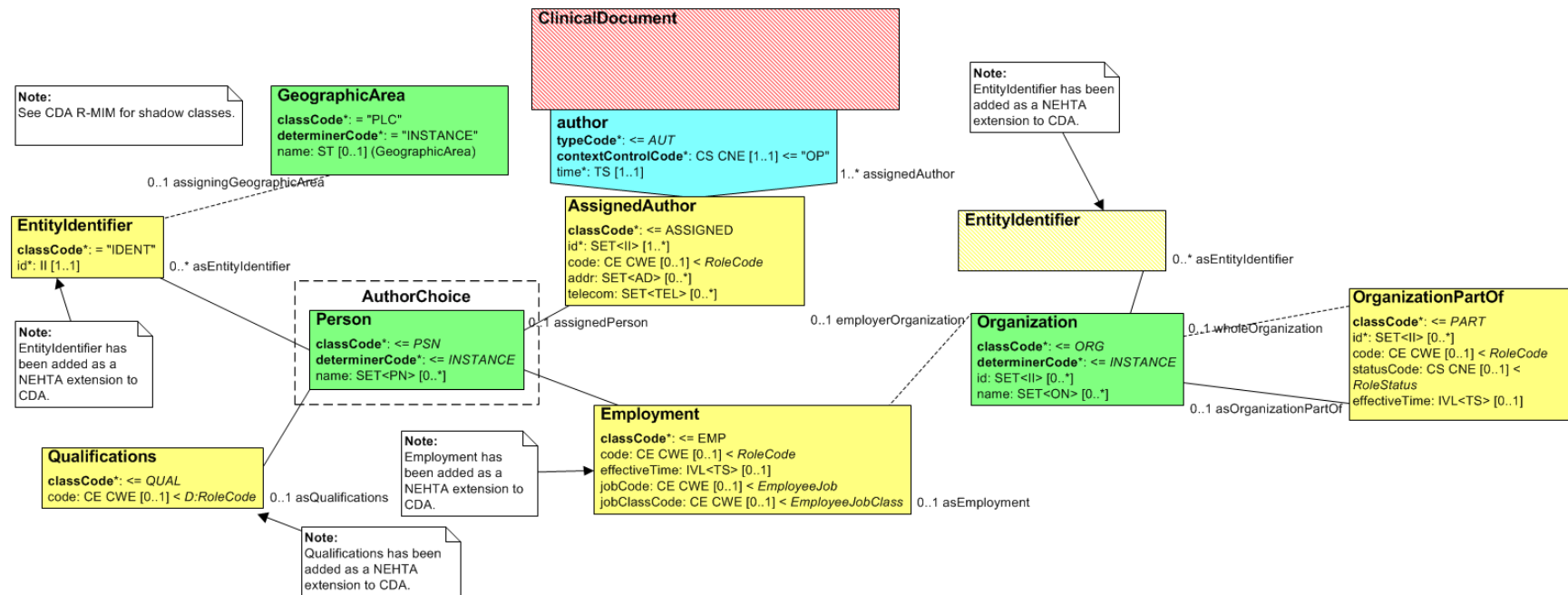

Figure 6.4. DOCUMENT AUTHOR

Figure 6.5 DOCUMENT AUTHOR - Entitlement shows a subset of the CDA R-MIM containing those classes being referred to in the CDA Mapping. This data component maps to CDA Body elements.

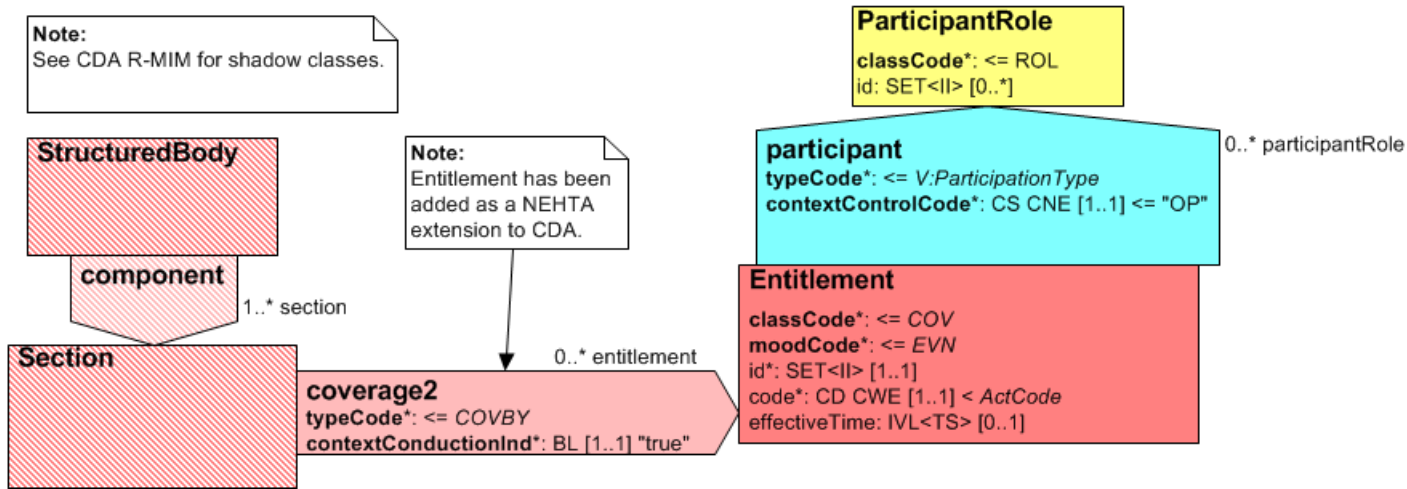

Figure 6.5. DOCUMENT AUTHOR - Entitlement

## CDA Mapping



### Note

CDA mapping for Document Author when Document Author > Participant > Person or Organisation or Device is instantiated as **PERSON (Healthcare Provider)**.

NEHTA SCS Data Component	Data Component Definition	Card	CDA Schema Data Element	Vocab	Comments
CDA Header Data Elements					
Context: ClinicalDocument/					
DOCUMENT AUTHOR	Composer of the document.	1..1	author		Document Author <b>SHALL</b> be filled with the Healthcare Provider who authored the document.
DOCUMENT AUTHOR > Participation Period	The time interval during which the participation in the health care event occurred.	1..1	author/time	Although the definition of this element states that it is a time interval, the following applies: "The end of the participation period of a Document Author participation is the time associated with the completion of editing the content of a document." Thus only the end time need be recorded.	Required CDA element.  The author/time element <b>SHALL</b> be implemented as either: <ul style="list-style-type: none"> <li>a value attribute (populated with the end time of the authorship or encounter, as appropriate); or</li> <li>a high element AND a low element, both with value attributes and neither with a nullFlavor attribute.</li> </ul>
DOCUMENT AUTHOR > Participation Type	The categorisation of the nature of the participant's involvement in the healthcare event described by this participation.	1..1	n/a	Participation Type <b>SHALL</b> have an implementation-specific value equivalent to "Document Author".	Not mapped directly; encompassed implicitly in author/typeCode="AUT" (optional, fixed value).
DOCUMENT AUTHOR > Role	The involvement or role of the participant in the related action from a healthcare perspective rather than the specific participation perspective.	1..1	author/assignedAuthor/code	Role <b>SHOULD</b> have a value chosen from <a href="#">1220.0 - ANZSCO - Australian and New Zealand Standard Classification of Occupations, First Edition, Revision 1 [ABS2009]</a> .  However, if a suitable value in this set cannot be found, then any code set that is both registered with HL7 and publicly available <b>MAY</b> be used.	See <code> for available attributes.

NEHTA SCS Data Component	Data Component Definition	Card	CDA Schema Data Element	Vocab	Comments
n/a	n/a	1..1	author/assignedAuthor/id	UUID  This is a technical identifier that is used for system purposes such as matching. If a suitable internal key is not available, a UUID <b>MAY</b> be used.	Required CDA element.
DOCUMENT AUTHOR > Participant	Details pertinent to the identification of an individual or organisation or device that has participated in a healthcare event/encounter/clinical interaction.	1..1	author/assignedAuthor/assignedPerson		
DOCUMENT AUTHOR > Participant > Entity Identifier	A number or code issued for the purpose of identifying a participant within a healthcare context.	1..*	author/assignedAuthor/assignedPerson/<Entity Identifier>	The value of one Entity Identifier <b>SHALL</b> be an Australian HPI-I.	See common pattern: <a href="#">Entity Identifier</a> .
DOCUMENT AUTHOR > Participant > Address	The description of a location where an entity is located or can be otherwise reached or found and a description of the purpose for which that address is primarily used by that entity.	0..*	author/assignedAuthor/<Address>	If present, AUSTRALIAN OR INTERNATIONAL ADDRESS <b>SHALL</b> be instantiated as an AUSTRALIAN ADDRESS.  Address Purpose (addr/@use) <b>SHALL</b> be set to Business (see <a href="#">AS 5017-2006: Health Care Client Identifier Address Purpose</a> ).	See common pattern: <a href="#">Address</a> .
DOCUMENT AUTHOR > Participant > Electronic Communication Detail	The electronic communication details of entities.	0..*	author/assignedAuthor/<Electronic Communication Detail>	Electronic Communication Usage Code (telecom/@use) <b>SHALL</b> be set to Workplace (see <a href="#">HL7: TelecommunicationAddressUse</a> ).	See common pattern: <a href="#">Electronic Communication Detail</a> .
DOCUMENT AUTHOR > Participant > Person or Organisation or Device	Represents a choice to be made at run-time between PERSON, ORGANISATION or DEVICE.	1..1	n/a	PERSON OR ORGANISATION OR DEVICE <b>SHALL</b> be instantiated as a PERSON.	This logical NEHTA data component has no mapping to CDA.  The cardinality of this component propagates to its children.
DOCUMENT AUTHOR > Participant > Person or Organisation or Device > Person	An individual who is in the role of healthcare provider, who uses or is a potential user of a healthcare service, or is in some way related to, or a representative of, a subject of care (patient).	1..1	n/a		Not mapped directly; encompassed implicitly in author/assignedAuthor/assignedPerson.
DOCUMENT AUTHOR > Participant > Person or Organisation or Device > Person > Person Name	The appellation by which an individual may be identified separately from any other within a social context.	1..*	author/assignedAuthor/assignedPerson/<Person Name>		See common pattern: <a href="#">Person Name</a> .
DOCUMENT AUTHOR > Participant > Person or Organisation or Device > Person > Employment Detail	A person's occupation and employer.	1..1	author/assignedAuthor/assignedPerson/<Employment>		See common pattern: <a href="#">Employment</a> .

NEHTA SCS Data Component	Data Component Definition	Card	CDA Schema Data Element	Vocab	Comments
<b>CDA Body Level 3 Data Elements</b>			Context: ClinicalDocument/component/structuredBody/component[admin_obs]/section/		
DOCUMENT AUTHOR > Participant > Entitlement	The entitlement or right of a participant to act in a given capacity (as defined by Entitlement Type) within a healthcare context.	0..*	<b>ext:coverage2/@typeCode="COVBY"</b>		
			ext:coverage2/ext:entitlement		
			ext:coverage2/ext:entitlement/@classCode="COV"		
			ext:coverage2/ext:entitlement/@moodCode="EVN"		
			ext:coverage2/ext:entitlement/ext:participant/@typeCode="HLD"		
			ext:coverage2/ext:entitlement/ext:participant/ext:participantRole/@classCode="ASSIGNED"		
			ext:coverage2/ext:entitlement/ext:participant/ext:participantRole/ext:id	UUID This is a technical identifier that is used for system purposes such as matching. If a suitable internal key is not available, a UUID <b>MAY</b> be used.	This <b>SHALL</b> hold the same value as author/assignedAuthor/id.
DOCUMENT AUTHOR > Participant > Entitlement > Entitlement Number	A number or code issued for the purpose of identifying the entitlement or right of a participant to act in a given capacity (as defined by Entitlement Type) within a healthcare context.	1..1	ext:coverage2/ext:entitlement/ext:id		See <id> for available attributes.
DOCUMENT AUTHOR > Participant > Entitlement > Entitlement Type	The description of the scope of an entitlement.	1..1	ext:coverage2/ext:entitlement/ext:code	<a href="#">NCTIS: Admin Codes - Entitlement Type</a>	
DOCUMENT AUTHOR > Participant > Entitlement > Entitlement Validity Duration	The time interval for which an entitlement is valid.	0..1	ext:coverage2/ext:entitlement/ext:effectiveTime		See <time> for available attributes.
<b>CDA Header Data Elements</b>			Context: ClinicalDocument/		
DOCUMENT AUTHOR > Participant > Qualifications	A list of professional certifications, and certificates recognising having passed a course.	0..1	author/assignedAuthor/assignedPerson/ext:asQualifications		See NEHTA CDA extension: <a href="#">Qualifications</a> .
			author/assignedAuthor/assignedPerson/ext:asQualifications/@classCode="QUAL"		
			author/assignedAuthor/assignedPerson/ext:asQualifications/ext:code/originalText	Qualifications is a text field, so the text list is entered in the originalText field of the code element.	



**Example 6.3. DOCUMENT AUTHOR XML Fragment (PERSON Healthcare Provider)**

<!-- This xml fragment is provided to demonstrate an example instance of each structured element in the CDA Mapping table. It is illustrative only. Logical model constraints on allowed combinations of child components are ignored in order to provide coverage of structured elements. This fragment cannot be treated as clinically valid. While the values in the fragment are conformant with the CDA Mapping table they are typically exaggerated to highlight the semantic meaning of the structured elements and may not be indicative of the expected values in a clinical document. While every effort has been taken to ensure that the examples are consistent with the message specification, where there are conflicts with the written message specification or schema, the specification or schema will take precedence. -->

```
<ClinicalDocument
  xmlns="urn:hl7-org:v3"
  xmlns:ext="http://ns.electronichealth.net.au/Ci/Cda/Extensions/3.0"
  ...
  >

  <!-- Begin CDA Header -->
  ...

  <!-- Begin Document Author as a Healthcare Person-->
  <author>
    <!-- DateTime Authored -->
    <time value="201110201235+1000" />
    <assignedAuthor>
      <!-- ID is used for system purposes such as matching -->
      <id root="db7637cf-50ed-4f3a-9f13-33f71a509578" />
      <!-- Role -->
      <code code="253915"
        codeSystem="2.16.840.1.113883.13.62"
        codeSystemName="1220.0 - ANZSCO - Australian and New Zealand Standard Classification of
        Occupations, First Edition, Revision 1"
        displayName="Pathologist"/>
      <!-- Address -->
      <addr use="WP">
        <streetAddressLine>1 Clinician Street</streetAddressLine>
        <city>Nehtaville</city>
        <state>QLD</state>
        <postalCode>5555</postalCode>
        <additionalLocator>32568931</additionalLocator>
      </addr>
      <!-- Electronic Communication Detail -->
      <telecom use="WP" value="tel:0712341234" />
      <!-- Participant -->
      <assignedPerson>
        <!-- Person Name -->
        <name>
          <prefix>Dr</prefix>
          <given>Robert</given>
          <family>Grant</family>
        </name>
        <!-- Entity Identifier -->
        <ext:asEntityIdentifier classCode="IDENT">
          <ext:id assigningAuthorityName="HPI-I" root="1.2.36.1.2001.1003.0.8003619900015717"/>
          <ext:assigningGeographicArea classCode="PLC">
            <ext:name>National Identifier</ext:name>
          </ext:assigningGeographicArea>
        </ext:asEntityIdentifier>
        <!-- Employment Details -->
        <ext:asEmployment classCode="EMP">
          <!-- Position In Organisation -->
          <ext:code>
            <originalText>Pathologist</originalText>
          </ext:code>
        </ext:asEmployment>
      </assignedPerson>
    </assignedAuthor>
  </author>

```

```
</ext:code>
<!-- Occupation -->
<ext:jobCode code="253915"
  codeSystem="2.16.840.1.113883.13.62"
  codeSystemName="1220.0 - ANZSCO - Australian and New Zealand Standard Classification of Occupations, First Edition, Revision 1"
  displayName="Pathologist" />
<!-- Employment Type -->
<ext:jobClassCode code="FT" codeSystem="2.16.840.1.113883.5.1059" codeSystemName="HL7:EmployeeJobClass"
  displayName="full-time" />
<!-- Employer Organisation -->
<ext:employerOrganization
  <!-- Department/Unit -->
  <name>Acme Hospital One</name>
  <asOrganizationPartOf>
  <wholeOrganization>
  <!-- Organisation Name -->
  <name use="ORGB">Acme Hospital Group</name>
  <!-- Entity Identifier -->
  <ext:asEntityIdentifier classCode="IDENT">
  <ext:id assigningAuthorityName="HPI-O" root="1.2.36.1.2001.1003.0.8003621566684455" />
  <ext:assigningGeographicArea classCode="PLC">
  <ext:name>National Identifier</ext:name>
  </ext:assigningGeographicArea>
  </ext:asEntityIdentifier>
  </wholeOrganization>
  </asOrganizationPartOf>
  </ext:employerOrganization>
</ext:asEmployment>
<ext:asQualifications classCode="QUAL">
<ext:code>
  <originalText>M.B.B.S</originalText>
</ext:code>
</ext:asQualifications>
</assignedPerson>
</assignedAuthor>
</author>
<!-- End Document Author as a Healthcare Person -->
...

<!-- End CDA Header -->

<!-- Begin CDA Body -->
<component>
<structuredBody>
...
<!-- Begin Section Administrative Observations -->
<component>
<section>
<id root="88CDBCA4-EFD1-11DF-8DE4-E4CDDFD72085" />
<code code="102.16080" codeSystem="1.2.36.1.2001.1001.101" codeSystemName="NCTIS Data Components" displayName="Administrative Observations" />
<title>Administrative Observations</title>
<!-- Begin Narrative text -->
<text>
<table>
<tbody>
<tr>
<th>Australian Medicare Prescriber Number</th>
<td>049960CT</td>
</tr>
</tbody>
</table>
</text>
<!-- End Narrative text -->
```

```
...
<!-- Begin Document Author Healthcare Provider Entitlement -->
<ext:coverage2 typeCode="COVBY">
  <ext:entitlement classCode="COV" moodCode="EVN">
    <ext:id assigningAuthorityName="Medicare Prescriber number"
      root="1.2.36.174030967.0.3"
      extension="049960CT"/>
    <ext:code code="10" codeSystem="1.2.36.1.2001.1001.101.104.16047"
      codeSystemName="NCTIS Entitlement Type Values"
      displayName="Medicare Prescriber Number"/>
    <ext:effectiveTime>
      <low value="20050101"/>
      <high value="20250101"/>
    </ext:effectiveTime>
    <ext:participant typeCode="HLD">
      <ext:participantRole classCode="ASSIGNED">
        <!-- Same as the prescriber (assignedAuthor) id -->
        <ext:id root="db7637cf-50ed-4f3a-9f13-33f71a509578"/>
      </ext:participantRole>
    </ext:participant>
  </ext:entitlement>
</ext:coverage2>
<!-- End Document Author Healthcare Provider Entitlement -->
...

</section>
</component>
<!-- End Section Administrative Observations -->
...

</structuredBody>
</component>
</ClinicalDocument>
```

## 6.1.3 ORDER DETAILS

### Identification

<b>Name</b>	ORDER DETAILS
<b>Metadata Type</b>	Data Group
<b>Identifier</b>	DG-16997

### Relationships

#### Parent

Data Type	Name	Occurrences (child within parent)
	<a href="#">Pathology Report with Structured Clinical Content (PATHOLOGY REPORT)</a>	1..1

## CDA R-MIM Representation

Figure 6.6 ORDER DETAILS shows a subset of the CDA R-MIM containing those classes being referred to in the CDA Mapping. This data component maps to CDA Header elements.

The ORDER DETAILS data group is represented by an Order class that is related to its containing Clinical Document by an inFulfillmentOf relationship. The id attribute of that Order class represents Order Identifier and the code attribute represents Order Name.

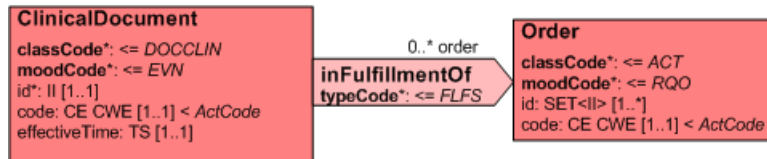

Figure 6.6. ORDER DETAILS

## CDA Mapping

NEHTA SCS Data Component	Data Component Definition	Card	CDA Schema Data Element	Vocab	Comments
CDA Header Data Elements			Context: ClinicalDocument/		
ORDER DETAILS	Details of order that led to the creation of the document.	1..1	<b>inFulfillmentOf</b>		This data component is only present when Order Name or Order Identifier is present.
			inFulfillmentOf/@typeCode="FLFS"		
			inFulfillmentOf/order		
			inFulfillmentOf/order/@classCode="ACT"		
			inFulfillmentOf/order/@moodCode="RQO"		
ORDER DETAILS > REQUESTER	Party that asks for or orders the provision of service.	1..1	<REQUESTER>		<p>The mapping for the Requester of the report does not follow the data hierarchy specified in the SCS. CDA does not allow (without extensions) participations on the Order class in the header.</p> <p>Receiving systems/applications are required to process "inFulfillmentOf-&gt; Order" and "Requester" details as integral/connected information components.</p>
ORDER DETAILS > Requester Order Identifier (Order Identifier)	The local identifier assigned to the order by the order requester.	0..1	inFulfillmentOf/order/id	<p>UUID</p> <p>This is a technical identifier that is used for system purposes such as matching. If a suitable internal key is not available, a UUID <b>MAY</b> be used.</p>	<p>Required CDA element.</p> <p>See common pattern: <a href="#">id</a>.</p> <p>The <a href="#">HPI-O based Local Order Identifier</a><sup>1</sup> is provided as a default option; if the organisation has some other OID to use to identify the Local System Identifier, then that OID should be used instead.</p> <p>The <i>HPI-O based Local Order Identifier</i> can be used as the root of an arc that organisations can use for their own local order IDs. This OID is never used directly; the 16 digit HPI-O is appended to the OID (i.e. 1.2.36.1.2001.1005.52.[HPI-O]) as the value of id/@root to identify that organisation's local order identifier which is the value of id/@extension.</p>

<sup>1</sup> [http://www.hl7.org/oid/index.cfm?Comp\\_OID=1.2.36.1.2001.1005.52](http://www.hl7.org/oid/index.cfm?Comp_OID=1.2.36.1.2001.1005.52)

NEHTA SCS Data Component	Data Component Definition	Card	CDA Schema Data Element	Vocab	Comments
ORDER DETAILS > <b>Requested Test Name (Order Name)</b>	Type of service ordered.	0..1	inFulfillmentOf/order/code	The code <b>SHOULD</b> be from the set of codes recommended for pathology terminology by the Royal College of Pathologists of Australasia which can be found at the <a href="https://www.nehta.gov.au/implementation-resources/terminology-access/#pathology">NEHTA Terminology Access</a> <sup>4</sup> website.	See <code> for available attributes.

<sup>4</sup> <https://www.nehta.gov.au/implementation-resources/terminology-access/#pathology>

## Example 6.4. ORDER DETAILS XML Fragment

<!-- This xml fragment is provided to demonstrate an example instance of each structured element in the CDA Mapping table. It is illustrative only. Logical model constraints on allowed combinations of child components are ignored in order to provide coverage of structured elements. This fragment cannot be treated as clinically valid. While the values in the fragment are conformant with the CDA Mapping table they are typically exaggerated to highlight the semantic meaning of the structured elements and may not be indicative of the expected values in a clinical document. While every effort has been taken to ensure that the examples are consistent with the message specification, where there are conflicts with the written message specification or schema, the specification or schema will take precedence. -->

```
<ClinicalDocument
  xmlns="urn:hl7-org:v3"
  xmlns:ext="http://ns.electronichealth.net.au/Ci/Cda/Extensions/3.0"
  ...
  >
  <!-- Begin CDA Header -->
  ...

  <!-- Begin ORDER DETAILS -->
  <inFulfillmentOf typeCode="FLFS">
    <order classCode="ACT" moodCode="RQO">
      <!-- Requester Order Identifier (Order Identifier) -->
      <!-- example showing root="[HPI-O based Local Order Identifier OID][HPI-O]". Requester number value used in extension -->
      <id extension="123451" root="1.2.36.1.2001.1005.52.8003621231166549" />
      <!-- Requested Test Name (Order Name) -->
      <code code="26604007"
            codeSystem="2.16.840.1.113883.6.96"
            codeSystemName="SNOMED CT-AU"
            displayName="Complete blood count"/>
    </order>
  </inFulfillmentOf>
  ...
  <!-- End CDA Header -->

  <!-- Begin CDA Body -->
  <component>
    <structuredBody>
      ...
    </structuredBody>
  </component>
  <!-- End CDA Body -->
</ClinicalDocument>
```



## 6.1.4 REQUESTER

### Identification

Name	REQUESTER
Metadata Type	Data Group
Identifier	DG-10296

### Relationships

#### Parent

Data Type	Name	Occurrences (child within parent)
	<a href="#">Pathology Report with Structured Clinical Content (PATHOLOGY REPORT)</a>	1..1

## **CDA R-MIM Representation**

Figure 6.7 REQUESTER shows a subset of the CDA R-MIM containing those classes being referred to in the CDA Mapping. This data component maps to CDA Header elements.

The REQUESTER data group instantiated as PERSON (Healthcare Provider) is related to its context of ClinicalDocument by the participant participation class. A participant is a person in the role of associatedEntity (AssociatedEntity class). The entity playing the role is associatedPerson (Person class). The entity identifier of the participant is mapped to the EntityIdentifier class (NEHTA CDA extension) and is associated to the associatedPerson.

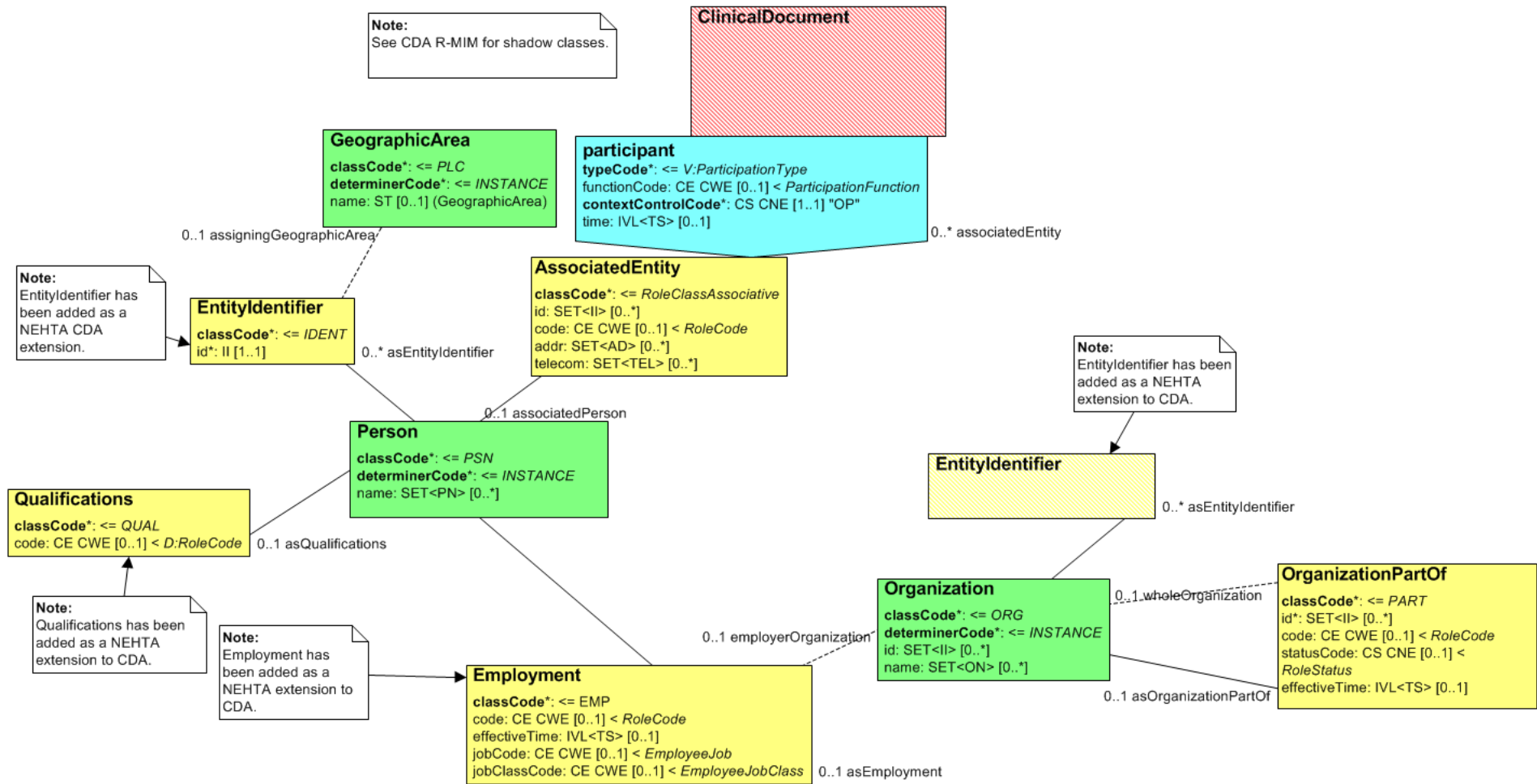

Figure 6.7. REQUESTER

Figure 6.8 REQUESTER - Entitlement shows a subset of the CDA R-MIM containing those classes being referred to in the CDA Mapping. This data component maps to CDA Body elements.

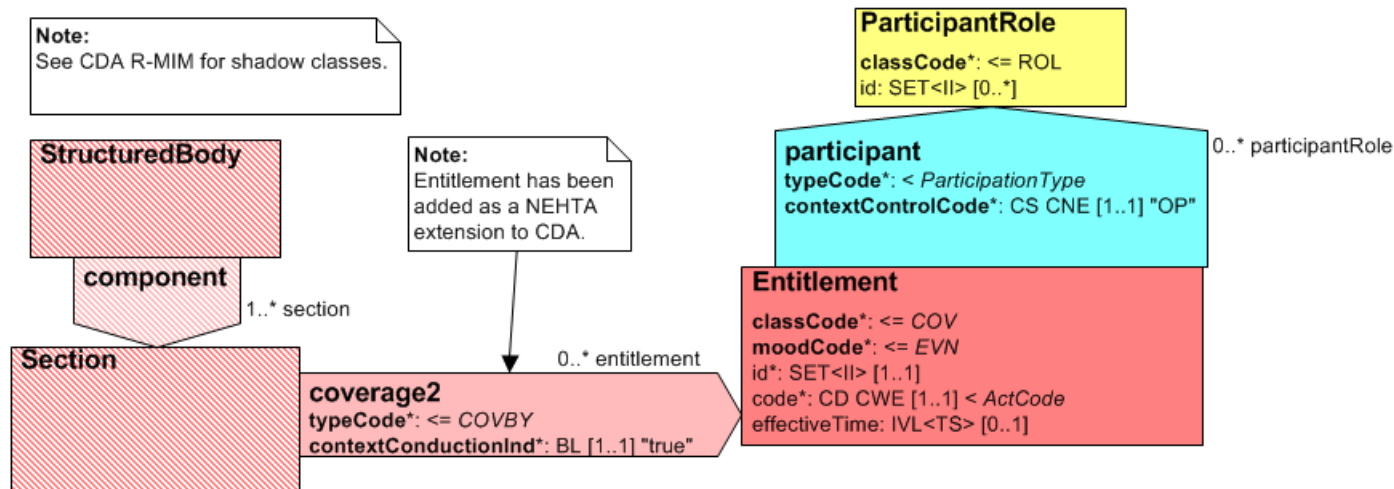

Figure 6.8. REQUESTER - Entitlement

## CDA Mapping



### Note

CDA mapping for REQUESTER when REQUESTER > Participant > Person or Organisation or Device is instantiated as **PERSON (Healthcare Provider)**.



### Note

NS = In the absence of national standard code sets, the code sets used **SHALL** be registered code sets, i.e. registered through the [HL7 code set registration procedure](#)<sup>5</sup> with an appropriate object identifier (OID), and **SHALL** be publicly available.

When national standard code sets become available, they **SHALL** be used and the non-standard code sets **SHALL** be deprecated.

NEHTA SCS Data Component	Data Component Definition	Card	CDA Schema Data Element	Vocab	Comments
<b>CDA Header Data Elements</b>					
Context: ClinicalDocument/					
REQUESTER	Party that asks for or orders the provision of service.	1..1	participant		Receiving systems/applications are required to process "inFulfillmentOf->Order" and "Requester" details as integral/connected information components.
REQUESTER > Participation Period	The time interval during which the participation in the health care event occurred.	0..1	participant/time	Although the definition of this element states that it is a time interval, the following applies: "The end of the participation period of a [Participant] participation is the time associated with the completion of editing the content..." Thus only the end time need be recorded.	The date, and optionally time, the request is made is contained in the Participation Period of the Requester.

<sup>5</sup> <http://www.hl7.org/oid/index.cfm?ref=footer>

NEHTA SCS Data Component	Data Component Definition	Card	CDA Schema Data Element	Vocab	Comments
REQUESTER > <b>Participation Type</b>	The categorisation of the nature of the participant's involvement in the healthcare event described by this participation.	1..1	n/a	Participation Type <b>SHALL</b> have an implementation-specific fixed value equivalent to "Service Requester".	Not mapped directly, encompassed implicitly in participant@typeCode="REF" (optional, fixed value).
n/a	n/a	1..1	participant/associatedEntity/id	UUID  This is a technical identifier that is used for system purposes such as matching. If a suitable internal key is not available, a UUID <b>MAY</b> be used.	Required CDA element.
REQUESTER > <b>Role</b>	The involvement or role of the participant in the related action from a healthcare perspective rather than the specific participation perspective.	1..1	participant/associatedEntity/code	Role <b>SHOULD</b> have a value chosen from <a href="#">1220.0 - ANZSCO - Australian and New Zealand Standard Classification of Occupations, First Edition, Revision 1 [ABS2009]</a> .  However, if a suitable value in this set cannot be found, then any code set that is both registered with HL7 and publicly available <b>MAY</b> be used.	
REQUESTER > <b>Participant</b>	Details pertinent to the identification of an individual or organisation or device that has participated in a healthcare event/encounter/clinical interaction.	1..1	participant/associatedEntity/associatedPerson		
REQUESTER > Participant > <b>Entity Identifier</b>	A number or code issued for the purpose of identifying a participant within a healthcare context.	0..*	participant/associatedEntity/associatedPerson/<Entity Identifier>	The value of one Entity Identifier <b>SHOULD</b> be an Australian HPI-I.	See common pattern: <a href="#">Entity Identifier</a> .

NEHTA SCS Data Component	Data Component Definition	Card	CDA Schema Data Element	Vocab	Comments
REQUESTER > Participant > <b>Address</b>	The description of a location where an entity is located or can be otherwise reached or found and a description of the purpose for which that address is primarily used by that entity.	0..*	participant/associatedEntity/ Address	AUSTRALIAN OR INTERNATIONAL ADDRESS <b>SHALL</b> be instantiated as an AUSTRALIAN ADDRESS.  Address Purpose (addr/@use) <b>SHALL</b> be set to Business (see <a href="#">AS 5017-2006: Health Care Client Identifier Address Purpose</a> ).	See common pattern: <a href="#">Address</a> .
REQUESTER > Participant > <b>Electronic Communication Detail</b>	The electronic communication details of entities.	0..*	participant/associatedEntity/ Electronic Communication Detail	Electronic Communication Usage Code (telecom/@use) <b>SHALL</b> be set to Workplace (see <a href="#">HL7: Telecommunication-AddressUse</a> ).	See common pattern: <a href="#">Electronic Communication Detail</a> .
REQUESTER > Participant > <b>Person or Organisation or Device</b>	Represents a choice to be made at run-time between PERSON, ORGANISATION or DEVICE.	1..1	n/a	PERSON OR ORGANISATION OR DEVICE <b>SHALL</b> be instantiated as a PERSON.	This logical NEHTA data component has no mapping to CDA.  The cardinality of this component propagates to its children.
REQUESTER > Participant > Person or Organisation or Device > <b>Person</b>	An individual who is in the role of healthcare provider, who uses or is a potential user of a healthcare service, or is in some way related to, or a representative of, a subject of care (patient).	1..1	n/a		Not mapped directly, encompassed implicitly in participant/associatedEntity/associatedPerson.
REQUESTER > Participant > Person or Organisation or Device > Person > <b>Person Name</b>	The appellation by which an individual may be identified separately from any other within a social context.	1..*	participant/associatedEntity/associatedPerson/ Person Name		See common pattern: <a href="#">Person Name</a> .
REQUESTER > Participant > Person or Organisation or Device > Person > <b>Employment Detail</b>	A person's occupation and employer.	0..1	participant/associatedEntity/associatedPerson/ext:asEmployment		

NEHTA SCS Data Component	Data Component Definition	Card	CDA Schema Data Element	Vocab	Comments
REQUESTER > Participant > Person or Organisation or Device > Person > Employment Detail > <b>Employer Organisation</b>	The organisation that the individual is working for in respect to the role they are playing in the nominated participation.	0..*	participant/associatedEntity/associatedPerson/ext:asEmployment/ext:employerOrganization  participant/associatedEntity/associatedPerson/ext:asEmployment/@classCode="EMP"		There is a known issue in the NEHTA Participation Data Specification [NE-HT2011v] for this logical data component's cardinality.  Furthermore the corresponding CDA elements ext:asEmployment and ext:employerOrganization do not allow the cardinality to be '0..*/multiple'. The cardinality <b>SHALL</b> be interpreted as '0..1' instead of '0..*'.  
REQUESTER > Participant > Person or Organisation or Device > Person > Employment Detail > Employer Organisation > <b>Entity Identifier</b>	A number or code issued for the purpose of identifying a participant within a healthcare context.	0..*	participant/associatedEntity/associatedPerson/ext:asEmployment/ext:employerOrganization/asOrganizationPartOf/wholeOrganization/<Entity Identifier>	The value of one Entity Identifier <b>SHOULD</b> be an Australian HPI-O.	See common pattern: <a href="#">Entity Identifier</a> .
REQUESTER > Participant > Person or Organisation or Device > Person > Employment Detail > Employer Organisation > <b>Organisation</b>	Any organisation of interest to, or involved in, the business of healthcare service provision.	1..1	n/a		Not mapped directly, encompassed implicitly in assignedAuthor/ext:asEmployment/employerOrganization.
REQUESTER > Participant > Person or Organisation or Device > Person > Employment Detail > Employer Organisation > Organisation > <b>Organisation Name</b>	The name by which an organisation is known or called.	1..1	participant/associatedEntity/associatedPerson/ext:asEmployment/ext:employerOrganization/asOrganizationPartOf/wholeOrganization/name		
REQUESTER > Participant > Person or Organisation or Device > Person > Employment Detail > Employer Organisation > Organisation > <b>Department/Unit</b>	The name by which a department or unit within a larger organisation is known or called.	0..1	participant/associatedEntity/associatedPerson/ext:asEmployment/ext:employerOrganization/name		
REQUESTER > Participant > Person or Organisation or Device > Person > Employment Detail > Employer Organisation > Organisation > <b>Organisation Name Usage</b>	The classification that enables differentiation between recorded names for an organisation or service location.	0..1	participant/associatedEntity/associatedPerson/ext:asEmployment/ext:employerOrganization/asOrganizationPartOf/wholeOrganization/name/@use	AS 4846-2006: <a href="#">Health Care Provider Organisation Name Usage</a>	



NEHTA SCS Data Component	Data Component Definition	Card	CDA Schema Data Element	Vocab	Comments
REQUESTER > Participant > Person or Organisation or Device > Person > Employment Detail > <b>Employment Type</b>	The basis on which the person is employed by the employer organisation.	0..1	participant/associatedEntity/associatedPerson/ext:asEmployment/ext:jobClassCode	NS	
REQUESTER > Participant > Person or Organisation or Device > Person > Employment Detail > <b>Occupation</b>	A descriptor of the class of job based on similarities in the tasks undertaken.	0..*	participant/associatedEntity/associatedPerson/ext:asEmployment/ext:jobCode	<a href="#">1220.0 - ANZSCO - Australian and New Zealand Standard Classification of Occupations, First Edition, Revision 1 [ABS2009]</a>	The corresponding CDA element ext:jobCode does not allow the cardinality to be '0..*/multiple'. The cardinality <b>SHALL</b> be interpreted as '0..1' instead of '0..*'. <b>SHALL</b>
REQUESTER > Participant > Person or Organisation or Device > Person > Employment Detail > <b>Position In Organisation</b>	A descriptor of the job or the job role based on the management hierarchy of the organisation.	0..1	participant/associatedEntity/associatedPerson/ext:asEmployment/ext:code	NS	
<b>CDA Body Level 3 Data Elements</b>			Context: ClinicalDocument/component/structuredBody/component[admin_obs]/section/		
REQUESTER > Participant > <b>Entitlement</b>	The entitlement or right of a participant to act in a given capacity (as defined by Entitlement Type) within a healthcare context.	0..*	ext:coverage2/@typeCode="COVBY"		
			ext:coverage2/ext:entitlement		
			ext:coverage2/ext:entitlement/@classCode="COV"		
			ext:coverage2/ext:entitlement/@moodCode="EVN"		
			ext:coverage2/ext:entitlement/ext:participant/@typeCode="HLD"		
			ext:coverage2/ext:entitlement/ext:participant/ext:participantRole/@classCode="ASSIGNED"		
			ext:coverage2/ext:entitlement/ext:participant/ext:participantRole/ext:id	UUID This is a technical identifier that is used for system purposes such as matching. If a suitable internal key is not available, a UUID <b>MAY</b> be used.	This <b>SHALL</b> hold the same value as participant/associatedEntity/id.
REQUESTER > Participant > Entitlement > <b>Entitlement Number</b>	A number or code issued for the purpose of identifying the entitlement or right of a participant to act in a given capacity (as defined by Entitlement Type) within a healthcare context.	1..1	ext:coverage2/ext:entitlement/ext:id		See <id> for available attributes.
REQUESTER > Participant > Entitlement > <b>Entitlement Type</b>	The description of the scope of an entitlement.	1..1	ext:coverage2/ext:entitlement/ext:code	<a href="#">NCTIS: Admin Codes - Entitlement Type</a>	

NEHTA SCS Data Component	Data Component Definition	Card	CDA Schema Data Element	Vocab	Comments
REQUESTER > Participant > Entitlement > <b>Entitlement Validity Duration</b>	The time interval for which an entitlement is valid.	0..1	ext:coverage2/ext:entitlement/ <b>ext:effectiveTime</b>		See <time> for available attributes.
<b>CDA Header Data Elements</b>			Context: ClinicalDocument/		
REQUESTER > Participant > <b>Qualifications</b>	A list of professional certifications, and certificates recognising having passed a course.	0..1	participant/associatedEntity/associatedPerson/ <b>ext:asQualifications</b>		See NEHTA CDA extension: <a href="#">Qualifications</a> .  Qualifications is a text field, so the text list is entered in the originalText field of the code element.
			participant/associatedEntity/associatedPerson/ext:asQualifications/ <b>@classCode="QUAL"</b>		
			participant/associatedEntity/associatedPerson/ext:asQualifications/ <b>ext:code/originalText</b>		

**Example 6.5. REQUESTER XML Fragment**

<!-- This xml fragment is provided to demonstrate an example instance of each structured element in the CDA Mapping table. It is illustrative only. Logical model constraints on allowed combinations of child components are ignored in order to provide coverage of structured elements. This fragment cannot be treated as clinically valid. While the values in the fragment are conformant with the CDA Mapping table they are typically exaggerated to highlight the semantic meaning of the structured elements and may not be indicative of the expected values in a clinical document. While every effort has been taken to ensure that the examples are consistent with the message specification, where there are conflicts with the written message specification or schema, the specification or schema will take precedence. -->

```
<ClinicalDocument
  xmlns="urn:hl7-org:v3"
  xmlns:ext="http://ns.electronichealth.net.au/Ci/Cda/Extensions/3.0"
  ...
  >
  ...
  <!-- Begin CDA Header -->
  ...
  <!-- Begin REQUESTER -->
  <participant typeCode="REF">
    <time value="201308071639+1000"/>
    <associatedEntity classCode="ASSIGNED">
      <id root="3ee928c0-4100-11e3-aa6e-0800200c9a66" />
      <code code="253111" codeSystem="2.16.840.1.113883.13.62"
        codeSystemName="1220.0 - ANZSCO - Australian and New Zealand Standard Classification
        of Occupations, First Edition, Revision 1"
        displayName="General Medical Practitioner" />
      <addr use="WP">
        <streetAddressLine>19 Park Tce</streetAddressLine>
        <city>Canberra</city>
        <state>ACT</state>
        <postalCode>2600</postalCode>
      </addr>
      <telecom use="WP" value="tel:0422222222" />
      <telecom use="WP" value="mailto:annasmith@internetprovider.com.au" />
      <associatedPerson>
        <!-- Person Name -->
        <name>
          <prefix>Dr.</prefix>
          <given>Anna</given>
          <family>SMITH</family>
        </name>
        <!-- Entity Identifier -->
        <ext:asEntityIdentifier classCode="IDENT">
          <ext:id assigningAuthorityName="HPI-I"
            root="1.2.36.1.2001.1003.0.8003610200002355" />
          <ext:assigningGeographicArea classCode="PLC">
            <ext:name>National Identifier</ext:name>
          </ext:assigningGeographicArea>
        </ext:asEntityIdentifier>
        <!-- Employment Details -->
        <ext:asEmployment classCode="EMP">
          <!-- Position In Organisation -->
          <ext:code>
            <originalText>General Practitioner</originalText>
          </ext:code>
        </ext:asEmployment>
      </associatedPerson>
    </associatedEntity>
  </participant>
  ...
  </ClinicalDocument>
```

```

</ext:code>
<!-- Occupation -->
<ext:jobCode code="253111" codeSystem="2.16.840.1.113883.13.62"
  codeSystemName="1220.0 - ANZSCO - Australian and New Zealand Standard
  Classification of Occupations, First Edition, Revision 1"
  displayName="General Medical Practitioner" />
<!-- Employment Type -->
<ext:jobClassCode code="FT" codeSystem="2.16.840.1.113883.5.1059"
  codeSystemName="HL7:EmployeeJobClass" displayName="full-time" />
<!-- Employer Organisation -->
<ext:employerOrganization>
  <!-- Department/Unit -->
  <name>GP Clinic</name>
  <asOrganizationPartOf>
    <wholeOrganization>
      <!-- Organisation Name -->
      <name use="ORGB">GP Group</name>
      <!-- Entity Identifier -->
      <ext:asEntityIdentifier classCode="IDENT">
        <ext:id assigningAuthorityName="HPI-O"
          root="1.2.36.1.2001.1003.0.8003621231166549" />
        <ext:assigningGeographicArea classCode="PLC">
          <ext:name>National Identifier</ext:name>
        </ext:assigningGeographicArea>
      </ext:asEntityIdentifier>
    </wholeOrganization>
  </asOrganizationPartOf>
</ext:employerOrganization>
</ext:asEmployment>

<ext:asQualifications classCode="QUAL">
  <ext:code>
    <originalText>M.B.B.S</originalText>
  </ext:code>
</ext:asQualifications>

</associatedPerson>
</associatedEntity>
</participant>
<!-- End REQUESTER -->
...

<!-- End CDA Header -->

<!-- Begin CDA Body -->
<component>
  <structuredBody>
    ...
    <!-- Begin Section Administrative Observations -->
    <component>
      <section>
        <id root="88CDBCA4-EFD1-11DF-8DE4-E4CDDFD72085" />
        <code code="102.16080" codeSystem="1.2.36.1.2001.1001.101" codeSystemName="NCTIS Data Components" displayName="Administrative Observations" />
        ...
        <text>
          <table>
            <tbody>
              <tr>
                <th>Australian Medicare Prescriber Number</th>
                <td>049960CT</td>
              </tr>
            </tbody>
          </table>
        </text>
      </section>
    </component>
  </structuredBody>
</component>

```

```
</text>

<!-- Begin REQUESTER Entitlement -->
<ext:coverage2 typeCode="COVBY">
  <ext:entitlement classCode="COV" moodCode="EVN">
    <ext:id assigningAuthorityName="Medicare Prescriber number"
      root="1.2.36.174030967.0.3"
      extension="049960CT"/>
    <ext:code code="10" codeSystem="1.2.36.1.2001.1001.101.104.16047"
      codeSystemName="NCTIS Entitlement Type Values"
      displayName="Medicare Prescriber Number"/>
    <ext:effectiveTime>
      <low value="20050101"/>
      <high value="20250101"/>
    </ext:effectiveTime>
    <ext:participant typeCode="HLD">
      <ext:participantRole classCode="ASSIGNED">
        <ext:id root="3ee928c0-4100-11e3-aa6e-0800200c9a66"/>
      </ext:participantRole>
    </ext:participant>
  </ext:entitlement>
</ext:coverage2>
<!-- End REQUESTER Entitlement -->
...
</section>
</component>
<!-- End Section Administrative Observations -->
...
</structuredBody>
</component>
<!-- End CDA Body -->
</ClinicalDocument>
```

# 7 Content Data Specification - CDA Mapping

## 7.1 Pathology Report with Structured Clinical Content

### Identification

<b>Name</b>	Pathology Report with Structured Clinical Content (PATHOLOGY REPORT)
<b>Metadata Type</b>	Structured Document
<b>Identifier</b>	SD-32001

### Relationships

#### Children

Data Type	Name	Occurrence
	PATHOLOGY	1..1

## CDA R-MIM Representation

Figure 7.1 Pathology Report with Structured Clinical Content shows a subset of the CDA R-MIM containing those classes being referred to in the CDA Mapping. This data component maps to CDA Body elements.

The Pathology Report with Structured Clinical Content is composed of a ClinicalDocument class, which is the entry point into the CDA R-MIM. The ClinicalDocument is associated with the bodyChoice through the component relationship. The StructuredBody class represents a CDA document body that is comprised of one or more document sections.

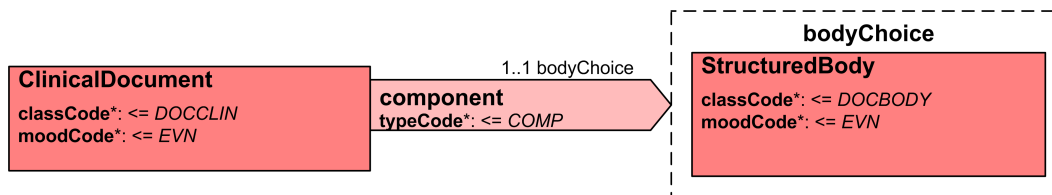

**Figure 7.1. Pathology Report with Structured Clinical Content**

## CDA Mapping

NEHTA SCS Data Component	Data Component Definition	Card	CDA Schema Data Element	Vocab	Comments
<b>CDA Header Data Elements</b>					
<b>Pathology Report with Structured Clinical Content</b>	A set of one or more results of pathology tests and their associated interpretation.	1..1	<b>ClinicalDocument</b>		
<b>CDA Body Level 2 Data Elements</b>					
Pathology Report with Structured Clinical Content (Body)	See above.	1..1	ClinicalDocument/ <b>component/structuredBody</b>		



## Example 7.1. Pathology Report with Structured Clinical Content Body XML Fragment

<!-- This xml fragment is provided to demonstrate an example instance of each structured element in the CDA Mapping table. It is illustrative only. Logical model constraints on allowed combinations of child components are ignored in order to provide coverage of structured elements. This fragment cannot be treated as clinically valid. While the values in the fragment are conformant with the CDA Mapping table they are typically exaggerated to highlight the semantic meaning of the structured elements and may not be indicative of the expected values in a clinical document. While every effort has been taken to ensure that the examples are consistent with the message specification, where there are conflicts with the written message specification or schema, the specification or schema will take precedence. -->

```
<ClinicalDocument xmlns="urn:hl7-org:v3"
  xmlns:ext="http://ns.electronichealth.net.au/Ci/Cda/Extensions/3.0"
  ...
  >
  ...
  <!-- Begin CDA Header -->
  ...
  <!-- End CDA Header -->
  <!-- Begin CDA Body -->
  <component>
    <structuredBody>
      ...
      <!-- Begin PATHOLOGY -->
      ...
      <!-- End PATHOLOGY -->
    </structuredBody>
  </component>
  <!-- End CDA Body -->
</ClinicalDocument>
```

## 7.1.1 PATHOLOGY

### Identification



<b>Name</b>	PATHOLOGY
<b>Metadata Type</b>	Section
<b>Identifier</b>	S-20018

### Relationships

#### Parent

Data Type	Name	Occurrences (child within parent)
	<a href="#">Pathology Report with Structured Clinical Content</a>	1..1

#### Children

Data Type	Name	Occurrence
	<a href="#">REPORTING PATHOLOGIST</a>	1..1
	<a href="#">PATHOLOGY TEST RESULT</a>	1..*
	<a href="#">RELATED DOCUMENT</a>	0..1

## CDA R-MIM Representation

Figure 7.2 PATHOLOGY shows a subset of the CDA R-MIM containing those classes being referred to in the CDA Mapping. This data component maps to CDA Body elements.

The PATHOLOGY section is composed of a Section class related to its context ClinicalDocument.structuredBody by a component.

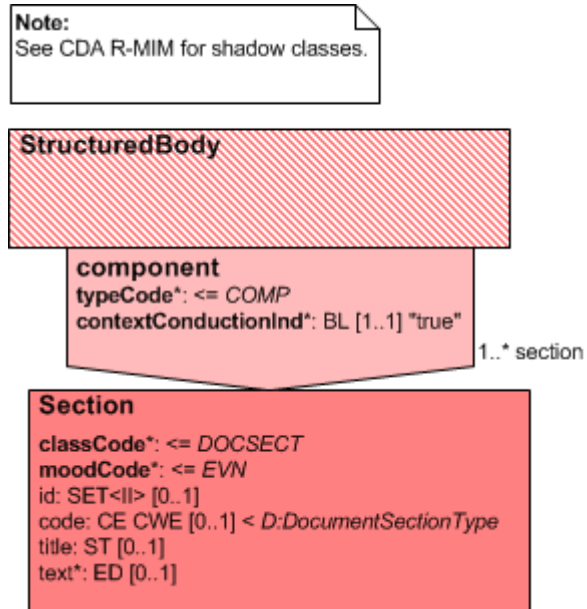

**Figure 7.2. PATHOLOGY**

## CDA Mapping

NEHTA SCS Data Component	Data Component Definition	Card	CDA Schema Data Element	Vocab	Comments
<b>CDA Body Level 2 Data Elements</b>			Context: ClinicalDocument/component/structuredBody/		
PATHOLOGY	Group of pathology test results concerning a subject of care and supporting information.	1..1	component[pathology]/section		The title <b>SHALL</b> only be present where narrative (section/text) is present.  See <a href="#">Appendix A, CDA Narratives</a> and the requirements for narrative sections in <a href="#">Clinical Documents Common Conformance Profile [NEHT2015t]</a> .
			component[pathology]/section/title="Pathology"		
			component[pathology]/section/text		
PATHOLOGY > Pathology Section Instance Identifier (Pathology Instance Identifier)	A globally unique identifier for each instance of a Pathology section.	1..1	component[pathology]/section/id	UUID  This is a technical identifier that is used for system purposes such as matching. If a suitable internal key is not available, a UUID <b>MAY</b> be used.	See <id> for available attributes.
PATHOLOGY > Section Type	Type of section.	1..1	component[pathology]/section/code		Optional CDA element.
			component[pathology]/section/code/@code="101.20018"		
			component[pathology]/section/code/@codeSystem="1.2.36.1.2001.1001.101"		
			component[pathology]/section/code/@codeSystemName	The value <b>SHOULD</b> be "NCTIS Data Components".  See <a href="#">CodeSystem OIDs</a> .	
			component[pathology]/section/code/@displayName="Pathology"		
PATHOLOGY > REPORTING PATHOLOGIST	Pathologist who is responsible for the pathology test result.	1..1	See: <a href="#">REPORTING PATHOLOGIST</a>		
PATHOLOGY > PATHOLOGY TEST RESULT	Findings and interpretation of pathology tests performed on one or more specimens obtained from a person or environment.	1..*	See: <a href="#">PATHOLOGY TEST RESULT</a>		
<b>CDA Body Level 3 Data Elements</b>			Context: ClinicalDocument/component/structuredBody/component[pathology]/section/		
PATHOLOGY > RELATED DOCUMENT	Information about a document of interest.	0..1	See: <a href="#">RELATED DOCUMENT</a>		

**Example 7.2. PATHOLOGY XML Fragment**

<!-- This xml fragment is provided to demonstrate an example instance of each structured element in the CDA Mapping table. It is illustrative only. Logical model constraints on allowed combinations of child components are ignored in order to provide coverage of structured elements. This fragment cannot be treated as clinically valid. While the values in the fragment are conformant with the CDA Mapping table they are typically exaggerated to highlight the semantic meaning of the structured elements and may not be indicative of the expected values in a clinical document. While every effort has been taken to ensure that the examples are consistent with the message specification, where there are conflicts with the written message specification or schema, the specification or schema will take precedence. -->

```
<ClinicalDocument
  xmlns="urn:hl7-org:v3"
  xmlns:ext="http://ns.electronichealth.net.au/Ci/Cda/Extensions/3.0"
  ...
  >

  <!-- Begin CDA Header -->
  ...

  <!-- End CDA Header -->

  <!-- Begin CDA Body -->
  <component>
    <structuredBody>
      ...

      <!-- Begin PATHOLOGY -->
      <component typeCode="COMP">
        <section classCode="DOCSECT" moodCode="EVN">
          <!-- Pathology Instance Identifier -->
          <id root="50846572-EFC7-11E0-8337-65094924019B" />
          <!-- Section Type -->
          <code code="101.20018" codeSystem="1.2.36.1.2001.1001.101" codeSystemName="NCTIS Data Components" displayName="Pathology"/>
          <title>Pathology</title>

          <!-- Begin Narrative text -->
          <text>Narrative Text</text>
          <!-- End Narrative text -->

          <!-- Begin PATHOLOGY TEST RESULT -->
          ...
          <!-- End PATHOLOGY TEST RESULT -->

          <!-- Begin REPORTING PATHOLOGIST -->
          ...
          <!-- End REPORTING PATHOLOGIST -->

          <!-- Begin RELATED DOCUMENT -->
          ...
          <!-- End RELATED DOCUMENT -->

        </section>
      </component>
      <!-- End PATHOLOGY -->

    </structuredBody>
  </component>
  <!-- End CDA Body -->
</ClinicalDocument>
```

## 7.1.1.1 PATHOLOGY TEST RESULT

### Identification



<b>Name</b>	PATHOLOGY TEST RESULT
<b>Metadata Type</b>	Data Group
<b>Identifier</b>	DG-16144

### Relationships

#### Parent

Data Type	Name	Occurrences (child within parent)
	<a href="#">PATHOLOGY</a>	1..*

#### Children

Data Type	Name	Occurrence
	<a href="#">Test Specimen Detail (SPECIMEN)</a>	1..*
	<a href="#">Result Group (PATHOLOGY TEST RESULT GROUP)</a>	0..*
	<a href="#">REPORTING PATHOLOGIST</a>	0..1

## CDA R-MIM Representation

Figure 7.3 **PATHOLOGY TEST RESULT** shows a subset of the CDA R-MIM containing those classes being referred to in the CDA Mapping. This data component maps to CDA Body elements.

The PATHOLOGY TEST RESULT data group is represented by a Section class that is related to its containing Section class by a component. Pathology Test Result Name is represented by an Observation class related to the Section (PATHOLOGY TEST RESULT) class by an entry. The id attribute of that Observation class represents Laboratory Test Result Identifier, and the value attribute represents Test Result Representation.

There are four Observation classes related to the containing Observation (Pathology Test Result Name) class by entryRelationships: Diagnostic Service, Overall Pathology Test Result Status, Pathological Diagnosis, and Observation DateTime. Pathology Test Conclusion is represented by a reference Observation class related to the containing Pathology Test Result Observation class by an entryRelationship.

Clinical Information Provided is represented by an Act class that is related to the containing Observation (Pathology Test Result Name) class by an entryRelationship. Test Comment is represented by an Act class that is related to the containing Pathology Test Result Observation class by an entryRelationship.

TEST REQUEST DETAILS is represented by a subject Act class that is related to the containing Observation (Pathology Test Result Name) class by an entryRelationship. Test Requested Name is represented by an Observation class that is related to its containing Act (TEST REQUEST DETAILS) class by an entryRelationship.

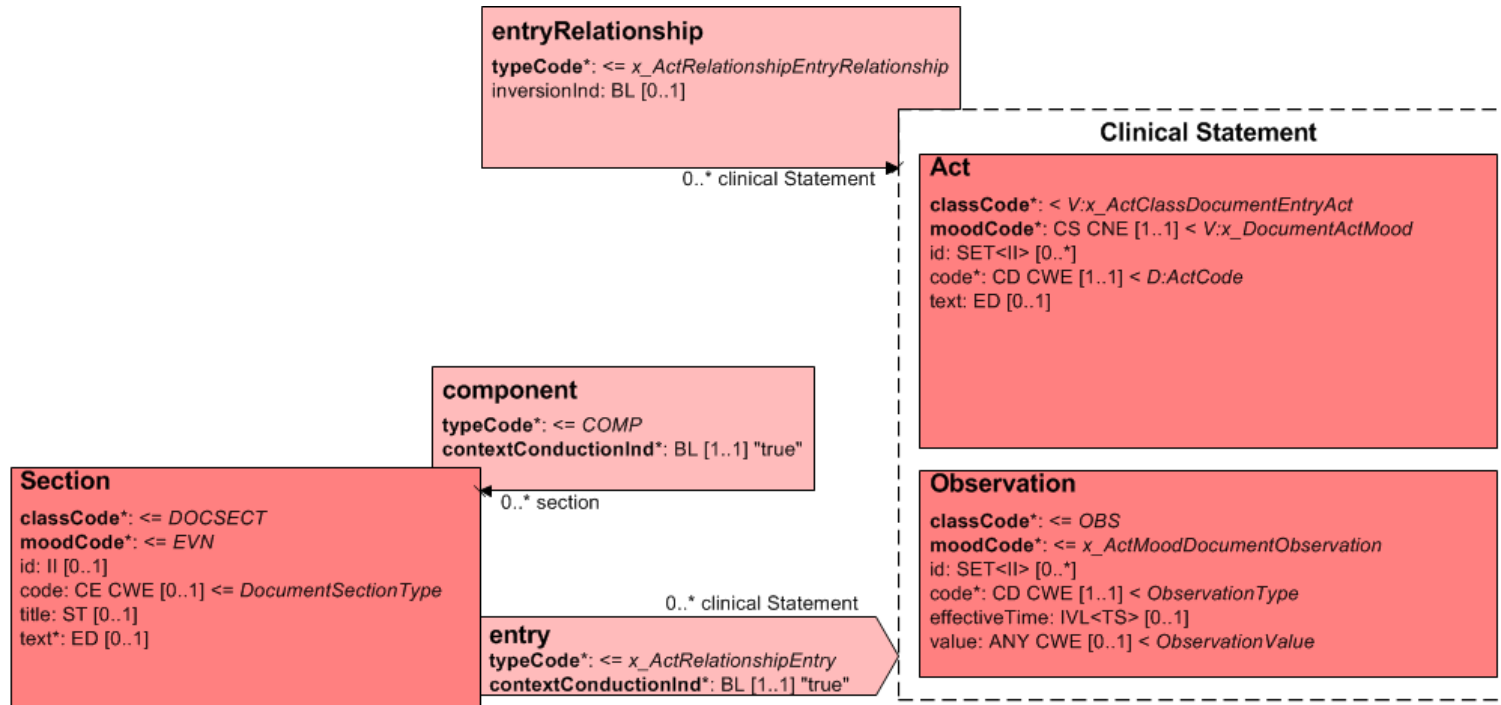

Figure 7.3. PATHOLOGY TEST RESULT



## CDA Mapping



### Note

NS = In the absence of national standard code sets, the code sets used **SHALL** be registered code sets, i.e. registered through the [HL7 code set registration procedure](#)<sup>1</sup> with an appropriate object identifier (OID), and **SHALL** be publicly available.

When national standard code sets become available, they **SHALL** be used and the non-standard code sets **SHALL** be deprecated.

NEHTA SCS Data Component	Data Component Definition	Card	CDA Schema Data Element	Vocab	Comments
<b>CDA Body Level 2 Data Elements</b>			Context: ClinicalDocument/component/structuredBody/component[pathology]/section/		
PATHOLOGY TEST RESULT	Findings and interpretation of pathology tests performed on one or more specimens obtained from a person or environment.	1..*	<b>component[path_test]/section</b>		The title <b>SHALL</b> only be present where narrative (section/text) is present.  See <a href="#">Appendix A, CDA Narratives</a> and the requirements for narrative sections in <a href="#">Clinical Documents Common Conformance Profile [NEHT2015t]</a> .
			component[path_test]/section/title="Pathology Test Result"		
			component[path_test]/section/text		
PATHOLOGY TEST RESULT > <b>Pathology Test Result Instance Identifier</b>	A globally unique identifier for each instance of a Pathology Test Result observation.	1..1	component[path_test]/section/id	UUID  This is a technical identifier that is used for system purposes such as matching. If a suitable internal key is not available, a UUID <b>MAY</b> be used.	See <id> for available attributes.
PATHOLOGY TEST RESULT > <b>Detailed Clinical Model Identifier</b>	A globally unique identifier for this Detailed Clinical Model.	1..1	component[path_test]/section/code		Optional CDA element.  The value <b>SHOULD</b> be "NCTIS Data Components".  See <a href="#">CodeSystem OIDs</a> .
			component[path_test]/section/code/@code="102.16144"		
			component[path_test]/section/code/@codeSystem="1.2.36.1.2001.1001.101"		
			component[path_test]/section/code/@codeSystemName		
			component[path_test]/section/code/@displayName="Pathology Test Result"		

<sup>1</sup> <http://www.hl7.org/oid/index.cfm?ref=footer>

NEHTA SCS Data Component	Data Component Definition	Card	CDA Schema Data Element	Vocab	Comments
<b>CDA Body Level 3 Data Elements</b>			Context: ClinicalDocument/component/structuredBody/component[pathology]/section/component[path_test]/section/		
PATHOLOGY TEST RESULT > <b>Test Result Name (Pathology Test Result Name)</b>	Identification of the pathology test performed, sometimes including specimen type.	1..1	<b>entry[path_test_res]/observation</b>		
			entry[path_test_res]/observation/@classCode="OBS"		
			entry[path_test_res]/observation/@moodCode="EVN"		
			entry[path_test_res]/observation/code:CD	The code <b>SHOULD</b> be from the set of codes recommended for pathology terminology by the Royal College of Pathologists of Australasia which can be found at the <a href="#">NEHTA Terminology Access</a> <sup>2</sup> website.	See <code> for available attributes.  When a <i>Pathology Test Result</i> record contains only a single individual test, this name may be the same as the name of the individual test.
<b>CDA Body Level 3 Data Elements</b>			Context: ClinicalDocument/component/structuredBody/component[pathology]/section/component[path_test]/section/entry[path_test_res]/observation/		
PATHOLOGY TEST RESULT > <b>Diagnostic Service</b>	The diagnostic service that performs the examination.	1..1	<b>entryRelationship[diag_serv]/@typeCode="COMP"</b>		
			entryRelationship[diag_serv]/observation		
			entryRelationship[diag_serv]/observation/@classCode="OBS"		
			entryRelationship[diag_serv]/observation/@moodCode="EVN"		
			entryRelationship[diag_serv]/observation/code		
			entryRelationship[diag_serv]/observation/code/@code="310074003"		
			entryRelationship[diag_serv]/observation/code/@codeSystem="2.16.840.1.113883.6.96"		
			entryRelationship[diag_serv]/observation/code/@codeSystemName	The value <b>SHOULD</b> be "SNOMED CT".  See <a href="#">CodeSystem OIDs</a> .	Optional CDA element.
			entryRelationship[diag_serv]/observation/code/@displayName="pathology service"		
entryRelationship[diag_serv]/observation/value:CD	<a href="#">HL7: Diagnostic Service Section ID</a>	See <code> for available attributes.			
PATHOLOGY TEST RESULT > <b>Test Specimen Detail (SPECIMEN)</b>	Details about specimens to which this test result refers.	1..*	See: <a href="#">Test Specimen Detail (SPECIMEN)</a>		

<sup>2</sup> <https://www.nehta.gov.au/implementation-resources/terminology-access/#pathology>

NEHTA SCS Data Component	Data Component Definition	Card	CDA Schema Data Element	Vocab	Comments
PATHOLOGY TEST RESULT > <b>Overall Pathology Test Result Status</b>	The status of the pathology test result as a whole.	1..1	<b>entryRelationship[res_stat]/@typeCode="COMP"</b>		
			entryRelationship[res_stat]/observation		
			entryRelationship[res_stat]/observation/@classCode="OBS"		
			entryRelationship[res_stat]/observation/@moodCode="EVN"		
			entryRelationship[res_stat]/observation/id	UUID  This is a technical identifier that is used for system purposes such as matching. If a suitable internal key is not available, a UUID <b>MAY</b> be used.	See <id> for available attributes.
			entryRelationship[res_stat]/observation/code		
			entryRelationship[res_stat]/observation/code/@code="308552006"		
			entryRelationship[res_stat]/observation/code/@codeSystem="2.16.840.1.113883.6.96"		
			entryRelationship[res_stat]/observation/code/@codeSystemName	The value <b>SHOULD</b> be "SNOMED CT".  See <a href="#">CodeSystem OIDs</a> .	Optional CDA element.
			entryRelationship[res_stat]/observation/code/@displayName="report status"		
entryRelationship[res_stat]/observation/value:CD	<a href="#">HL7: Result Status</a>	See <code> for available attributes.			
PATHOLOGY TEST RESULT > <b>Clinical Information Provided</b>	Description or summary of relevant, prior clinical information that may help in determining the test(s) to be performed, or interpreting the result when compiling or reading the report.	0..1	<b>entryRelationship[clin_info_prov]/@typeCode="COMP"</b>		
			entryRelationship[clin_info_prov]/act		
			entryRelationship[clin_info_prov]/act/@classCode="INFRM"		
			entryRelationship[clin_info_prov]/act/@moodCode="EVN"		
			entryRelationship[clin_info_prov]/act/code		
			entryRelationship[clin_info_prov]/act/code/@code="55752-0"		
			entryRelationship[clin_info_prov]/act/code/@codeSystem="2.16.840.1.113883.6.1"		
			entryRelationship[clin_info_prov]/act/code/@codeSystemName	The value <b>SHOULD</b> be "LOINC".  See <a href="#">CodeSystem OIDs</a> .	Optional CDA element.
			entryRelationship[clin_info_prov]/act/code/@displayName="Clinical information"		
			entryRelationship[clin_info_prov]/act/text:ST		

NEHTA SCS Data Component	Data Component Definition	Card	CDA Schema Data Element	Vocab	Comments
PATHOLOGY TEST RESULT > <b>Result Group (PATHOLOGY TEST RESULT GROUP)</b>	A group of results that form all or part of a recognisable pathology test.	0..*	See: <a href="#">Result Group (PATHOLOGY TEST RESULT GROUP)</a>		
PATHOLOGY TEST RESULT > <b>Pathological Diagnosis</b>	Single word, phrase or brief description representing the diagnostic statement as asserted by the reporting pathologist.	0..*	<b>entryRelationship[path_diag]/@typeCode="REFR"</b>		
			entryRelationship[path_diag]/ <b>observation</b>		
			entryRelationship[path_diag]/observation/@ <b>classCode="OBS"</b>		
			entryRelationship[path_diag]/observation/@ <b>moodCode="EVN"</b>		
			entryRelationship[path_diag]/observation/ <b>code</b>		
			entryRelationship[path_diag]/observation/code/@ <b>code="88101002"</b>		
			entryRelationship[path_diag]/observation/code/@ <b>codeSystem="2.16.840.1.113883.6.96"</b>		
			entryRelationship[path_diag]/observation/code/@ <b>codeSystemName</b>	The value <b>SHOULD</b> be "SNOMED CT". See <a href="#">CodeSystem OIDs</a> .	Optional CDA element.
			entryRelationship[path_diag]/observation/code/@ <b>displayName="pathology diagnosis"</b>		
entryRelationship[path_diag]/observation/ <b>value:CD[LIST]</b>	NS	The cardinality (0..*) of this component is represented by a list of value:CD.			

NEHTA SCS Data Component	Data Component Definition	Card	CDA Schema Data Element	Vocab	Comments
PATHOLOGY TEST RESULT > <b>Conclusion (Pathology Test Conclusion)</b>	Concise and clinically contextualised narrative interpretation of the pathology test results.	0..1	<b>entryRelationship[path_conc]/@typeCode="REFR"</b>		
			entryRelationship[path_conc]/observation		
			entryRelationship[path_conc]/observation/@classCode="OBS"		
			entryRelationship[path_conc]/observation/@moodCode="EVN"		
			entryRelationship[path_conc]/observation/id	UUID  This is a technical identifier that is used for system purposes such as matching. If a suitable internal key is not available, a UUID <b>MAY</b> be used.	See <id> for available attributes.
			entryRelationship[path_conc]/observation/code		
			entryRelationship[path_conc]/observation/code/@code="386344002"		
			entryRelationship[path_conc]/observation/code/@codeSystem="2.16.840.1.113883.6.96"		
			entryRelationship[path_conc]/observation/code/@codeSystemName	The value <b>SHOULD</b> be "SNOMED CT".  See <a href="#">CodeSystem OIDs</a> .	Optional CDA element.
			entryRelationship[path_conc]/observation/code/@displayName="laboratory findings data interpretation"		
entryRelationship[path_conc]/observation/value:ST					
PATHOLOGY TEST RESULT > <b>Test Result Representation</b>	Rich text representation of the entire result as issued by the diagnostic service.	0..1	<b>value:ED</b>		

NEHTA SCS Data Component	Data Component Definition	Card	CDA Schema Data Element	Vocab	Comments
PATHOLOGY TEST RESULT > <b>Test Comment</b>	Additional narrative about the test that is not captured in other fields.	0..1	<b>entryRelationship[tst_cmt]/@typeCode="COMP"</b>		
			entryRelationship[tst_cmt]/act		
			entryRelationship[tst_cmt]/act/@classCode="INFRM"		
			entryRelationship[tst_cmt]/act/@moodCode="EVN"		
			entryRelationship[tst_cmt]/act/code		
			entryRelationship[tst_cmt]/act/code/@code="103.16468"		
			entryRelationship[tst_cmt]/act/code/@codeSystem="1.2.36.1.2001.1001.101"		
			entryRelationship[tst_cmt]/act/code/@codeSystemName	The value <b>SHOULD</b> be "NCTIS Data Components". See <a href="#">CodeSystem OIDs</a> .	Optional CDA element.
			entryRelationship[tst_cmt]/act/code/@displayName="Test Comment"		
			entryRelationship[tst_cmt]/act/text:ST		
PATHOLOGY TEST RESULT > <b>TEST REQUEST DETAILS</b>	Details concerning a single requested pathology test.	0..*	<b>entryRelationship[req_dets]/@typeCode="SUBJ"</b>		
			entryRelationship[req_dets]/@inversionInd="true"		
			entryRelationship[req_dets]/act		
			entryRelationship[req_dets]/act/@classCode="ACT"		
			entryRelationship[req_dets]/act/@moodCode="EVN"		
			entryRelationship[req_dets]/act/code		
			entryRelationship[req_dets]/act/code/@code="102.16160"		
			entryRelationship[req_dets]/act/code/@codeSystem="1.2.36.1.2001.1001.101"		
			entryRelationship[req_dets]/act/code/@codeSystemName	The value <b>SHOULD</b> be "NCTIS Data Components". See <a href="#">CodeSystem OIDs</a> .	Optional CDA element.
			entryRelationship[req_dets]/act/code/@displayName="Test Request Details"		

NEHTA SCS Data Component	Data Component Definition	Card	CDA Schema Data Element	Vocab	Comments
PATHOLOGY TEST RESULT > TEST REQUEST DETAILS > <b>Requester Order Identifier (Order Identifier)</b>	The local identifier assigned to the order by the order requester.	0..1	entryRelationship[req_dets]/act/id		<p>See common pattern: <a href="#">id</a>.</p> <p>The <a href="#">HPI-O based Local Order Identifier</a><sup>3</sup> is provided as a default option; if the organisation has some other OID to use to identify the Local System Identifier, then that OID should be used instead.</p> <p>The <a href="#">HPI-O based Local Order Identifier</a> can be used as the root of an arc that organisations can use for their own local order IDs. This OID is never used directly; the 16 digit HPI-O is appended to the OID (i.e. 1.2.36.1.2001.1005.52.[HPI-O]) as the value of <code>id/@root</code> to identify that organisation's local order identifier which is the value of <code>id/@extension</code>.</p>

<sup>3</sup> [http://www.hl7.org/oid/index.cfm?Comp\\_OID=1.2.36.1.2001.1005.52](http://www.hl7.org/oid/index.cfm?Comp_OID=1.2.36.1.2001.1005.52)

NEHTA SCS Data Component	Data Component Definition	Card	CDA Schema Data Element	Vocab	Comments	
PATHOLOGY TEST RESULT > TEST REQUEST DETAILS > <b>Test Requested Name</b>	Identification of the pathology test which was requested.	0..*	entryRelationship[req_dets]/act/entryRelationship[req_name]/@typeCode="COMP"		This logical NEHTA data component <b>SHOULD NOT</b> be present if its value is equal to the value of the Pathology Test Result Name (entry[path_test_res]/observation/code).	
			entryRelationship[req_dets]/act/entryRelationship[req_name]/observation			
			entryRelationship[req_dets]/act/entryRelationship[req_name]/observation/@classCode="OBS"			
			entryRelationship[req_dets]/act/entryRelationship[req_name]/observation/@moodCode="RQO"			
			entryRelationship[req_dets]/act/entryRelationship[req_name]/observation/code			
			entryRelationship[req_dets]/act/entryRelationship[req_name]/observation/code/@code="103.16404"			
			entryRelationship[req_dets]/act/entryRelationship[req_name]/observation/code/@codeSystem="1.2.36.1.2001.1001.101"			
			entryRelationship[req_dets]/act/entryRelationship[req_name]/observation/code/@codeSystemName	The value <b>SHOULD</b> be "NCTIS Data Components".  See <a href="#">CodeSystem OIDs</a> .		Optional CDA element.
			entryRelationship[req_dets]/act/entryRelationship[req_name]/observation/code/@displayName="Test Requested Name"			
	entryRelationship[req_dets]/act/entryRelationship[req_name]/observation/value:CD	The code <b>SHOULD</b> be from the set of codes recommended for pathology terminology by the Royal College of Pathologists of Australasia which can be found at the <a href="#">NEHTA Terminology Access</a> <sup>4</sup> website.				
PATHOLOGY TEST RESULT > TEST REQUEST DETAILS > <b>Laboratory Test Result Identifier</b>	The identifier given to the laboratory test result of a pathology investigation.	0..1	<b>id</b>		See <id> for available attributes.	

<sup>4</sup> <https://www.nehta.gov.au/implementation-resources/terminology-access/#pathology>



NEHTA SCS Data Component	Data Component Definition	Card	CDA Schema Data Element	Vocab	Comments
PATHOLOGY TEST RESULT > <b>Observation DateTime</b>	Date, and optionally time, when an observation is clinically significant to the condition of the subject of the observation.	1..1	<b>entryRelationship[tst_date]/@typeCode="COMP"</b>		
			entryRelationship[tst_date]/ <b>observation</b>		
			entryRelationship[tst_date]/observation/@ <b>classCode="OBS"</b>		
			entryRelationship[tst_date]/observation/@ <b>moodCode="EVN"</b>		
			entryRelationship[tst_date]/observation/ <b>id</b>	UUID  This is a technical identifier that is used for system purposes such as matching. If a suitable internal key is not available, a UUID <b>MAY</b> be used.	See <id> for available attributes.
			entryRelationship[tst_date]/observation/ <b>code</b>		Observation DateTime is mapped to Pathology Test Result DateTime and retains the original OID and displayName of that concept for backwards compatibility.
			entryRelationship[tst_date]/observation/code/@ <b>code="103.16605"</b>		
			entryRelationship[tst_date]/observation/code/@ <b>codeSystem="1.2.36.1.2001.1001.101"</b>		
			entryRelationship[tst_date]/observation/code/@ <b>codeSystemName</b>	The value <b>SHOULD</b> be "NCTIS Data Components".  See <a href="#">CodeSystem OIDs</a> .  Optional CDA element.	
			entryRelationship[tst_date]/observation/code/@ <b>displayName="Pathology Test Result DateTime"</b>		
entryRelationship[tst_date]/observation/ <b>effectiveTime</b>	This element will hold the same value as Test Specimen Detail (SPECIMEN) > HANDLING AND PROCESSING > <b>Collection DateTime</b> (entryRelationship[specimen]/observation/effectiveTime)	See <time> for available attributes.			

### Example 7.3. PATHOLOGY TEST RESULT XML Fragment

<!-- This xml fragment is provided to demonstrate an example instance of each structured element in the CDA Mapping table. It is illustrative only. Logical model constraints on allowed combinations of child components are ignored in order to provide coverage of structured elements. This fragment cannot be treated as clinically valid. While the values in the fragment are conformant with the CDA Mapping table they are typically exaggerated to highlight the semantic meaning of the structured elements and may not be indicative of the expected values in a clinical document. While every effort has been taken to ensure that the examples are consistent with the message specification, where there are conflicts with the written message specification or schema, the specification or schema will take precedence. -->

```
<ClinicalDocument xmlns="urn:h17-org:v3"
  xmlns:ext="http://ns.electronichealth.net.au/Ci/Cda/Extensions/3.0"
  ...
  >
  ...
  <!-- Begin CDA Header -->
  ...
  <!-- End CDA Header -->
  <!-- Begin CDA Body -->
  <component>
    <structuredBody>
      ...
      <!-- Begin PATHOLOGY -->
      <component typeCode="COMP">
        <section classCode="DOCSECT" moodCode="EVN">
          ...
          <!-- Begin PATHOLOGY TEST RESULT -->
          <component>
            <section classCode="DOCSECT" moodCode="EVN">
              <!-- Pathology Test Instance Identifier - used for system purposes such as matching -->
              <id root="CCF0D55C-EFD0-11DF-BEA2-AACCFD72085" />
              <!-- Detailed Clinical Model Identifier -->
              <code code="102.16144" codeSystem="1.2.36.1.2001.1001.101" codeSystemName="NCTIS Data Components"
                displayName="Pathology Test Result" />
              <title>Pathology Test Result</title>
              <text>
                <table>
                  <thead>
                    <tr>
                      <th>Test</th>
                      <th>Value</th>
                      <th>Units</th>
                      <th>Reference Range</th>
                      <th>Interpretation</th>
                      <th>DateTime</th>
                    </tr>
                  </thead>
                  <tbody>
                    <tr>
                      <td>Serum Creatinine</td>
                      <td>0.06</td>
                      <td>mmol/L</td>
                      <td>0.04-0.11</td>
                      <td>N</td>
                      <td>12/02/2013</td>
                    </tr>
                    <tr>
                      <td>Serum Uric Acid</td>

```

```

        <td>0.41</td>
        <td>mmol/L</td>
        <td>0.14-0.35</td>
        <td>HH</td>
        <td>12/02/2013</td>
    </tr>
</tbody>
</table>
<paragraph>
<linkHtml href="pathresult.pdf">Attached Pathology Result</linkHtml>
</paragraph>
</text>
<entry>
<observation classCode="OBS" moodCode="EVN">

<!-- Laboratory Test Result Identifier -->
<id root="8FC201B4-F2FA-11E0-906B-E4D04824019B" />

<!-- Test Result Name (Pathology Test Result Name) -->
<code code="275711006" codeSystem="2.16.840.1.113883.6.96" codeSystemName="SNOMED CT" displayName="Serum Chemistry Test" xsi:type="CD" />

<!-- Begin Test Result Representation -->
<value mediaType="application/pdf" xsi:type="ED">
  <reference value="pathresult.pdf" />
</value>
<!-- End Test Result Representation -->

<!-- Begin REPORTING PATHOLOGIST -->
<participant>
...
</participant>
<!-- End REPORTING PATHOLOGIST -->

<!-- Begin Diagnostic Service -->
<entryRelationship typeCode="COMP">
<observation classCode="OBS" moodCode="EVN">
  <code code="310074003" codeSystem="2.16.840.1.113883.6.96" codeSystemName="SNOMED CT" displayName="pathology service" />
  <value code="CH" codeSystem="2.16.840.1.113883.12.74" codeSystemName="HL7 Diagnostic service section ID" displayName="Chemistry" xsi:type="CD" />
</observation>
</entryRelationship>
<!-- End Diagnostic Service -->

<!-- Begin Test Specimen Detail (SPECIMEN) -->
<entryRelationship typeCode="SUBJ">
<observation classCode="OBS" moodCode="EVN">
...
</observation>
</entryRelationship>
<!-- End Test Specimen Detail (SPECIMEN) -->

<!-- Begin Overall Pathology Test Result Status -->
<entryRelationship typeCode="COMP">
<observation classCode="OBS" moodCode="EVN">
  <!-- ID is used for system purposes such as matching -->
  <id root="7AA9BAAC-0CD0-11E0-9516-4350DFD72085" />
  <code code="308552006" codeSystem="2.16.840.1.113883.6.96" codeSystemName="SNOMED CT"
    displayName="report status" />
  <value code="F"
    codeSystem="2.16.840.1.113883.12.123"
    codeSystemName="HL7 Result Status"
    displayName="Final results; results stored and verified. Can only be changed with a corrected result."
    xsi:type="CD" />

```

```
</observation>
</entryRelationship>
<!-- End Overall Pathology Test Result Status -->

<!-- Begin Clinical Information Provided -->
<entryRelationship typeCode="COMP">
  <act classCode="INFRM" moodCode="EVN">
    <code code="55752-0" codeSystem="2.16.840.1.113883.6.1" codeSystemName="LOINC"
      displayName="Clinical information" />
    <text>Bloods for evaluation.</text>
  </act>
</entryRelationship>
<!-- End Clinical Information Provided -->

<!-- Begin Result Group (PATHOLOGY TEST RESULT GROUP) -->
<entryRelationship typeCode="COMP">
  <organizer classCode="BATTERY" moodCode="EVN">
    ...
  </organizer>
</entryRelationship>
<!-- End Result Group (PATHOLOGY TEST RESULT GROUP) -->

<!-- Begin Pathological Diagnosis -->
<entryRelationship typeCode="REFR">
  <observation classCode="OBS" moodCode="EVN">
    <code code="88101002" codeSystem="2.16.840.1.113883.6.96" codeSystemName="SNOMED CT"
      displayName="pathology diagnosis" />
    <value code="301011002" codeSystem="2.16.840.1.113883.6.96" codeSystemName="SNOMED CT"
      displayName="Escherichia coli urinary tract infection" xsi:type="CD" />
    <value code="197940006" codeSystem="2.16.840.1.113883.6.96" codeSystemName="SNOMED CT"
      displayName="Microscopic haematuria" xsi:type="CD" />
  </observation>
</entryRelationship>
<!-- End Pathological Diagnosis -->

<!-- Begin Pathology Test Conclusion -->
<entryRelationship typeCode="REFR">
  <observation classCode="OBS" moodCode="EVN">
    <id root="060588DE-F2F9-11E0-ABE7-C7CE4824019B" />
    <code code="386344002" codeSystem="2.16.840.1.113883.6.96" codeSystemName="SNOMED CT"
      displayName="laboratory findings data interpretation" />
    <value xsi:type="ST">Chronic problems.</value>
  </observation>
</entryRelationship>
<!-- End Pathology Test Conclusion -->

<!-- Begin Test Comment -->
<entryRelationship typeCode="COMP">
  <act classCode="INFRM" moodCode="EVN">
    <code code="103.16468" codeSystem="1.2.36.1.2001.1001.101" codeSystemName="NCTIS Data Components"
      displayName="Test Comment" />
    <text>Known PKD</text>
  </act>
</entryRelationship>
<!-- End Test Comment -->

<!-- Begin TEST REQUEST DETAILS -->
<entryRelationship inversionInd="true" typeCode="SUBJ">
  <act classCode="ACT" moodCode="EVN">
    <!-- Requester Order Identifier (Order Identifier) -->
    <id root="0F4b40a5-9983-4f52-bde3-02d35a540bb9" />
    <code code="102.16160" codeSystem="1.2.36.1.2001.1001.101" codeSystemName="NCTIS Data Components"
```

```
    displayName="Test Request Details" />

<!-- Begin Test Requested Name -->
<entryRelationship typeCode="COMP">
  <observation classCode="OBS" moodCode="RQO">
    <code code="103.16404" codeSystem="1.2.36.1.2001.1001.101"
      codeSystemName="NCTIS Data Components" displayName="Test Requested Name" />
    <value code="401324008" codeSystem="2.16.840.1.113883.6.96" codeSystemName="SNOMED CT"
      displayName="Urinary microscopy, culture and sensitivities" xsi:type="CD" />
  </observation>
</entryRelationship>
<!-- End Test Requested Name -->

</act>
</entryRelationship>
<!-- End Test TEST REQUEST DETAILS -->

<!-- Begin Observation DateTime -->
<entryRelationship typeCode="COMP">
  <observation classCode="OBS" moodCode="EVN">
    <!-- ID is used for system purposes such as matching -->
    <id root="CCFPD55C-EFD0-11DF-BEA2-A6CCDFD72085" />
    <code code="103.16605" codeSystem="1.2.36.1.2001.1001.101" codeSystemName="NCTIS Data Components"
      displayName="Pathology Test Result DateTime" />
    <effectiveTime value="201310201235+1000" />
  </observation>
</entryRelationship>
<!-- End Observation DateTime -->

</observation>
</entry>
</section>
</component>
<!-- End PATHOLOGY TEST RESULT -->

...

</section>
</component>

<!-- End PATHOLOGY -->

...

</structuredBody>
</component>
<!-- End CDA Body -->
</ClinicalDocument>
```

### 7.1.1.1.1 Test Specimen Detail (SPECIMEN)

#### Identification

<b>Name</b>	Test Specimen Detail (SPECIMEN)
<b>Metadata Type</b>	Data Group
<b>Identifier</b>	DG-16156

#### Relationships

##### Parent

Data Type	Name	Occurrences (child within parent)
	PATHOLOGY TEST RESULT	1..*

## CDA R-MIM Representation

Figure 7.4 Test Specimen Detail (SPECIMEN) shows a subset of the CDA R-MIM containing those classes being referred to in the CDA Mapping. This data component maps to CDA Body elements.

The Test Specimen Detail (SPECIMEN) data group is represented by an Observation class that is related to its containing Observation (Pathology Test Result Name) class by an entryRelationship. The methodCode attribute of that Observation (SPECIMEN) class represents Collection Procedure, the effectiveTime attribute represents Collection DateTime, and targetSiteCode represents the ANATOMICAL LOCATION data elements.

Specimen Identifier is represented by the id attribute of a specimenRole which is related to its containing Observation (Pathology Test Result Name) class by a specimen participation. PHYSICAL PROPERTIES OF AN OBJECT is represented by a specimenPlayingEntity of the containing specimenRole. The code attribute of that specimenPlayingEntity represents Specimen Tissue Type, the quantity attribute represents Weight or Volume, and the desc attribute represents Object Description. Container Identifier is represented by the Container NEHTA CDA extension.

Anatomical Location Image and Image are both represented by a supporting ObservationMedia class related to the containing Observation (SPECIMEN) class by an entryRelationship.

There are four component Observation classes related to the containing Observation (SPECIMEN) class by entryRelationships: Sampling Preconditions, Collection Setting, DateTime Received, and Parent Specimen Identifier.

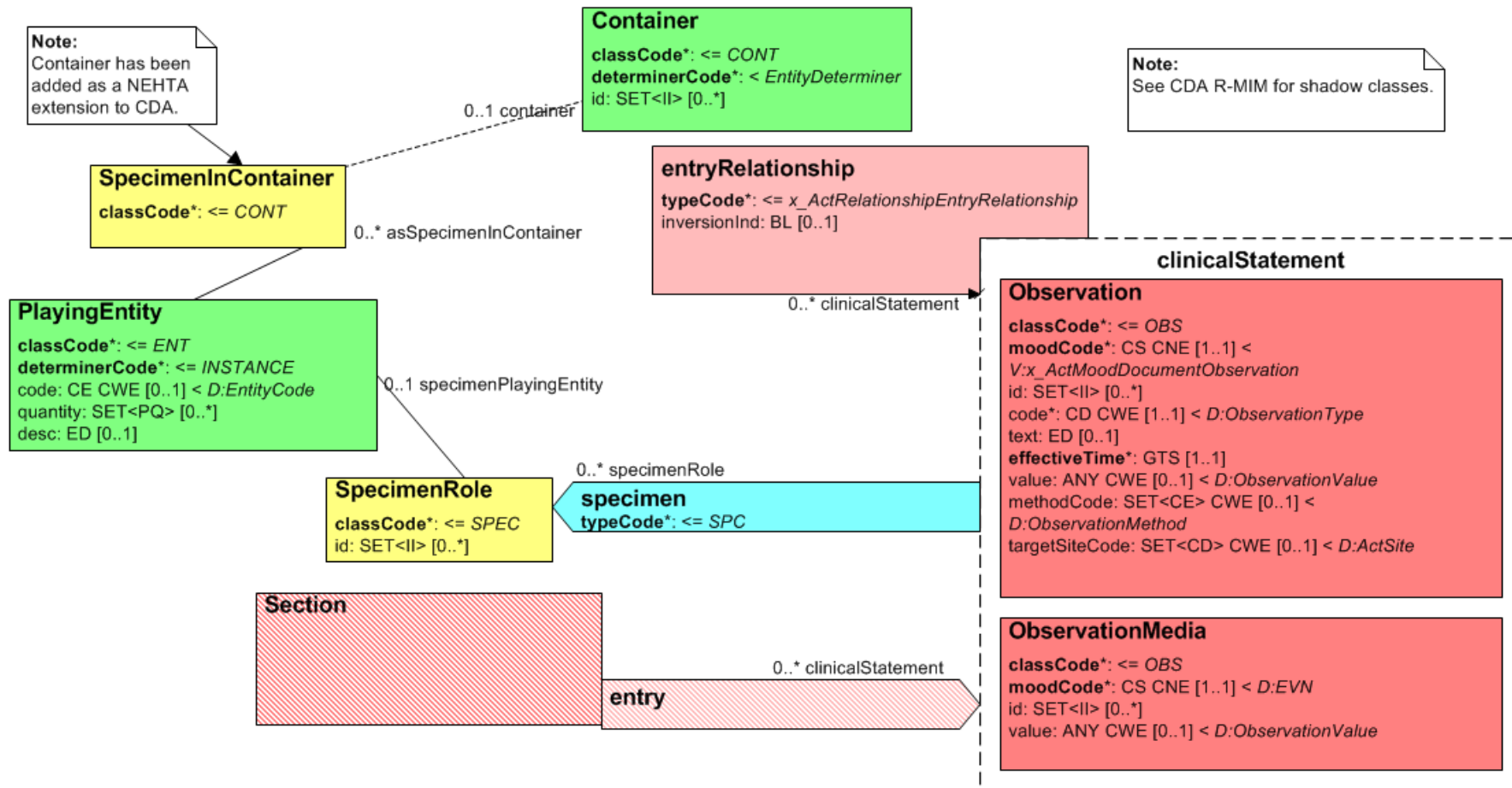

Figure 7.4. Test Specimen Detail (SPECIMEN)



## CDA Mapping



## Note

NS = In the absence of national standard code sets, the code sets used **SHALL** be registered code sets, i.e. registered through the [HL7 code set registration procedure](#)<sup>5</sup> with an appropriate object identifier (OID), and **SHALL** be publicly available.

When national standard code sets become available, they **SHALL** be used and the non-standard code sets **SHALL** be deprecated.

NEHTA SCS Data Component	Data Component Definition	Card	CDA Schema Data Element	Vocab	Comments
<b>CDA Body Level 3 Data Elements</b>			Context: ClinicalDocument/component/structuredBody/component[pathology]/section/component[path_test]/section/entry[path_test_res]/observation/		
Test Specimen Detail (SPECIMEN)	Details about specimens to which this test result refers.	1..*	entryRelationship[specimen]/@typeCode="SUBJ"		
			entryRelationship[specimen]/observation		
			entryRelationship[specimen]/observation/@classCode="OBS"		
			entryRelationship[specimen]/observation/@moodCode="EVN"		
			entryRelationship[specimen]/observation/code		
			entryRelationship[specimen]/observation/code/@code="102.16156.220.2.1"		
			entryRelationship[specimen]/observation/code/@codeSystem="1.2.36.1.2001.1001.101"		
			entryRelationship[specimen]/observation/code/@codeSystemName	The value <b>SHOULD</b> be "NCTIS Data Components".  See <a href="#">CodeSystem OIDs</a> .	Optional CDA element.
			entryRelationship[specimen]/observation/code/@displayName="Specimen"		
Test Specimen Detail (SPECIMEN) > Specimen Tissue Type	The type of specimen to be collected.	0..1	entryRelationship[specimen]/observation/specimen/specimenRole/specimenPlayingEntity/code	NS	See <code> for available attributes.
Test Specimen Detail (SPECIMEN) > Collection Procedure	The method of collection to be used.	0..1	entryRelationship[specimen]/observation/methodCode	NS	See <code> for available attributes.
Test Specimen Detail (SPECIMEN) > Anatomical Site (ANATOMICAL LOCATION)	The anatomical site from where the specimen was taken.	0..*	n/a	Each instance of Anatomical Site (ANATOMICAL LOCATION) <b>SHALL</b> contain either one instance of SPECIFIC LOCATION or one instance of Anatomical Location Description.	This logical NEHTA data component has no mapping to CDA.  The cardinality of this component propagates to its children.

<sup>5</sup> <http://www.hl7.org/oid/index.cfm?ref=footer>

NEHTA SCS Data Component	Data Component Definition	Card	CDA Schema Data Element	Vocab	Comments
Test Specimen Detail (SPECIMEN) > Anatomical Site (ANATOMICAL LOCATION) > <b>SPECIFIC LOCATION</b>	Specific and identified anatomical location.	0..1	n/a		This logical NEHTA data component has no mapping to CDA.  The cardinality of this component propagates to its children.
Test Specimen Detail (SPECIMEN) > Anatomical Site (ANATOMICAL LOCATION) > SPECIFIC LOCATION > <b>Anatomical Location Name</b>	The name of the anatomical location.	0..1	entryRelationship[specimen]/observation/ <b>targetSiteCode</b>	SNOMED CT-AU: <ul style="list-style-type: none"><li>32570061000036105  Body structure foundation reference set </li></ul>	See <code> for available attributes.
Test Specimen Detail (SPECIMEN) > Anatomical Site (ANATOMICAL LOCATION) > SPECIFIC LOCATION > <b>Side</b>	The laterality of the anatomical location.	0..1	entryRelationship[specimen]/observation/targetSiteCode/ <b>qualifier</b>		
			entryRelationship[specimen]/observation/targetSiteCode/ <b>qualifier/name</b>		
			entryRelationship[specimen]/observation/targetSiteCode/ <b>qualifier/name/@code="272741003"</b>		
			entryRelationship[specimen]/observation/targetSiteCode/ <b>qualifier/name/@codeSystem="2.16.840.1.113883.6.96"</b>		
			entryRelationship[specimen]/observation/targetSiteCode/ <b>qualifier/name/@codeSystemName</b>	The value <b>SHOULD</b> be "SNOMED CT".  See <a href="#">CodeSystem OIDs</a> .	Optional CDA element.
			entryRelationship[specimen]/observation/targetSiteCode/ <b>qualifier/name/@displayName="Laterality"</b>		
			entryRelationship[specimen]/observation/targetSiteCode/ <b>qualifier/value:CD</b>	SNOMED CT-AU: <ul style="list-style-type: none"><li>32570611000036103  Laterality reference set </li></ul>	See <code> for available attributes.
Test Specimen Detail (SPECIMEN) > Anatomical Site (ANATOMICAL LOCATION) > <b>Anatomical Location Description</b>	Description of the anatomical location.	0..1	entryRelationship[specimen]/observation/targetSiteCode/ <b>originalText</b>		Anatomical Location Description is an instance of targetSiteCode with only an originalText element.

NEHTA SCS Data Component	Data Component Definition	Card	CDA Schema Data Element	Vocab	Comments
Test Specimen Detail (SPECIMEN) > Anatomical Site (ANATOMICAL LOCATION) > <b>Anatomical Location Image</b>	An image or images used to identify a location.	0..*	entryRelationship[specimen]/observation/entryRelationship[ana_im]/@typeCode="SPRT"		The image may or may not be attested to and is therefore mapped to observationMedia.
			entryRelationship[specimen]/observation/entryRelationship[ana_im]/observationMedia		
			entryRelationship[specimen]/observation/entryRelationship[ana_im]/observationMedia/@classCode="OBS"		
			entryRelationship[specimen]/observation/entryRelationship[ana_im]/observationMedia/@moodCode="EVN"		
			entryRelationship[specimen]/observation/entryRelationship[ana_im]/observationMedia/id	UUID	See <id> for available attributes.  This is a technical identifier that is used for system purposes such as matching. If a suitable internal key is not available, a UUID <b>MAY</b> be used.
entryRelationship[specimen]/observation/entryRelationship[ana_im]/observationMedia/value					
Test Specimen Detail (SPECIMEN) > <b>Physical Details (PHYSICAL PROPERTIES OF AN OBJECT)</b>	Record of physical details, such as weight and dimensions, of a body part, device, lesion or specimen.	0..*	entryRelationship[specimen]/observation/specimen/specimenRole/specimenPlayingEntity		
Test Specimen Detail (SPECIMEN) > Physical Details (PHYSICAL PROPERTIES OF AN OBJECT) > <b>Weight</b>	Property of a body – commonly, but inadequately, defined as the quantity of matter in it – to which its inertia is ascribed, and expressed as the weight of the body divided by the acceleration due to gravity.	0..1	entryRelationship[specimen]/observation/specimen/specimenRole/specimenPlayingEntity/quantity:PQ		Either Weight or Volume <b>SHALL</b> be present. Weight and Volume <b>SHALL</b> be mutually exclusive.
Test Specimen Detail (SPECIMEN) > Physical Details (PHYSICAL PROPERTIES OF AN OBJECT) > <b>DIMENSIONS</b>	The dimensions of the object.	0..1	n/a		This logical NEHTA data component has no mapping to CDA.  The cardinality of this component propagates to its children.
Test Specimen Detail (SPECIMEN) > Physical Details (PHYSICAL PROPERTIES OF AN OBJECT) > DIMENSIONS > <b>Volume</b>	Size, measure or amount of anything in three dimensions; space occupied by a body or substance measured in cubic units.	0..1	entryRelationship[specimen]/observation/specimen/specimenRole/specimenPlayingEntity/quantity:PQ		Either Weight or Volume <b>SHALL</b> be present. Weight and Volume <b>SHALL</b> be mutually exclusive.

NEHTA SCS Data Component	Data Component Definition	Card	CDA Schema Data Element	Vocab	Comments
Test Specimen Detail (SPECIMEN) > Physical Details (PHYSICAL PROPERTIES OF AN OBJECT) > <b>Description (Object Description)</b>	A description of the physical characteristics of the object other than weight and volume.	0..1	entryRelationship[specimen]/observation/specimen/specimenRole/specimenPlayingEntity/ <b>desc:ST</b>		
Test Specimen Detail (SPECIMEN) > Physical Details (PHYSICAL PROPERTIES OF AN OBJECT) > <b>Image</b>	A picture of the object.	0..1	entryRelationship[specimen]/observation/ <b>entryRelationship[spec_im]/@typeCode="SPRT"</b>		The image may or may not be attested to and is therefore mapped to observationMedia.
			entryRelationship[specimen]/observation/entryRelationship[spec_im]/ <b>observationMedia</b>		
			entryRelationship[specimen]/observation/entryRelationship[spec_im]/observationMedia/ <b>@classCode="OBS"</b>		
			entryRelationship[specimen]/observation/entryRelationship[spec_im]/observationMedia/ <b>@moodCode="EVN"</b>		
			entryRelationship[specimen]/observation/entryRelationship[spec_im]/observationMedia/ <b>id</b>	UUID  This is a technical identifier that is used for system purposes such as matching. If a suitable internal key is not available, a UUID <b>MAY</b> be used.	
			entryRelationship[specimen]/observation/entryRelationship[spec_im]/observationMedia/ <b>value</b>		
Test Specimen Detail (SPECIMEN) > <b>COLLECTION AND HANDLING</b>	Collection and handling requirements.	0..1	n/a		This logical NEHTA data component has no mapping to CDA.  The cardinality of this component propagates to its children.

NEHTA SCS Data Component	Data Component Definition	Card	CDA Schema Data Element	Vocab	Comments
Test Specimen Detail (SPECIMEN) > COLLECTION AND HANDLING > <b>Sampling Preconditions</b>	Any conditions to be met before the sample should be taken.	0..1	entryRelationship[specimen]/observation/entryRelationship[smp_pre]/@typeCode="COMP"		
			entryRelationship[specimen]/observation/entryRelationship[smp_pre]/observation		
			entryRelationship[specimen]/observation/entryRelationship[smp_pre]/observation/@classCode="OBS"		
			entryRelationship[specimen]/observation/entryRelationship[smp_pre]/observation/@moodCode="EVN"		
			entryRelationship[specimen]/observation/entryRelationship[smp_pre]/observation/code		
			entryRelationship[specimen]/observation/entryRelationship[smp_pre]/observation/code/@code="103.16171"		
			entryRelationship[specimen]/observation/entryRelationship[smp_pre]/observation/code/@codeSystem="1.2.36.1.2001.1001.101"		
			entryRelationship[specimen]/observation/entryRelationship[smp_pre]/observation/code/@codeSystemName	The value <b>SHOULD</b> be "NCTIS Data Components".  See <a href="#">CodeSystem OIDs</a> .	Optional CDA element.
entryRelationship[specimen]/observation/entryRelationship[smp_pre]/observation/code/@displayName="Sampling Preconditions"					
			entryRelationship[specimen]/observation/entryRelationship[smp_pre]/observation/value:CD	NS	See <code> for available attributes.
Test Specimen Detail (SPECIMEN) > <b>HANDLING AND PROCESSING</b>	Workflow of specimen processing or handling.	1..1	n/a		This logical NEHTA data component has no mapping to CDA.  The cardinality of this component propagates to its children.
Test Specimen Detail (SPECIMEN) > HANDLING AND PROCESSING > <b>Date and Time of Collection (Collection DateTime)</b>	Date, and optionally time, of collection.	1..1	entryRelationship[specimen]/observation/effectiveTime		See <time> for available attributes.

NEHTA SCS Data Component	Data Component Definition	Card	CDA Schema Data Element	Vocab	Comments
Test Specimen Detail (SPECIMEN) > HANDLING AND PROCESSING > Collection Setting	Identification of the setting at which the specimen was collected from a subject of care.	0..1	entryRelationship[specimen]/observation/entryRelationship[coll_set]/@typeCode="COMP"		
			entryRelationship[specimen]/observation/entryRelationship[coll_set]/observation		
			entryRelationship[specimen]/observation/entryRelationship[coll_set]/observation/@classCode="OBS"		
			entryRelationship[specimen]/observation/entryRelationship[coll_set]/observation/@moodCode="EVN"		
			entryRelationship[specimen]/observation/entryRelationship[coll_set]/observation/code		
			entryRelationship[specimen]/observation/entryRelationship[coll_set]/observation/code/@code="103.16529"		
			entryRelationship[specimen]/observation/entryRelationship[coll_set]/observation/code/@codeSystem="1.2.36.1.2001.1001.101"		
			entryRelationship[specimen]/observation/entryRelationship[coll_set]/observation/code/@codeSystemName	The value <b>SHOULD</b> be "NCTIS Data Components".  See <a href="#">CodeSystem OIDs</a> .	Optional CDA element.
			entryRelationship[specimen]/observation/entryRelationship[coll_set]/observation/code/@displayName="Collection Setting"		
			entryRelationship[specimen]/observation/entryRelationship[coll_set]/observation/value:ST		
Test Specimen Detail (SPECIMEN) > HANDLING AND PROCESSING > Date and Time of Receipt (DateTime Received)	The date and time that the sample was received at the laboratory.	0..1	entryRelationship[specimen]/observation/entryRelationship[date_rec]/@typeCode="COMP"		
			entryRelationship[specimen]/observation/entryRelationship[date_rec]/observation		
			entryRelationship[specimen]/observation/entryRelationship[date_rec]/observation/@classCode="OBS"		
			entryRelationship[specimen]/observation/entryRelationship[date_rec]/observation/@moodCode="EVN"		
			entryRelationship[specimen]/observation/entryRelationship[date_rec]/observation/code		
			entryRelationship[specimen]/observation/entryRelationship[date_rec]/observation/code/@code="103.11014"		
			entryRelationship[specimen]/observation/entryRelationship[date_rec]/observation/code/@codeSystem="1.2.36.1.2001.1001.101"		
			entryRelationship[specimen]/observation/entryRelationship[date_rec]/observation/code/@codeSystemName	The value <b>SHOULD</b> be "NCTIS Data Components".  See <a href="#">CodeSystem OIDs</a> .	Optional CDA element.
			entryRelationship[specimen]/observation/entryRelationship[date_rec]/observation/code/@displayName="DateTime Received"		
			entryRelationship[specimen]/observation/entryRelationship[date_rec]/observation/value:TS		See <time> for available attributes.

NEHTA SCS Data Component	Data Component Definition	Card	CDA Schema Data Element	Vocab	Comments
Test Specimen Detail (SPECIMEN) > IDENTIFIERS	Sample identifications.	0..1	n/a		This logical NEHTA data component has no mapping to CDA.  The cardinality of this component propagates to its children.
Test Specimen Detail (SPECIMEN) > IDENTIFIERS > Specimen Identifier	Unique identifier of the specimen, normally assigned by the laboratory.	0..1	entryRelationship[specimen]/observation/specimen/specimenRole/id		See <id> for available attributes.
Test Specimen Detail (SPECIMEN) > Specimen Identifier > Parent Specimen Identifier	Unique identifier of the parent specimen where the specimen is split into sub-samples.	0..1	entryRelationship[specimen]/observation/entryRelationship[prnt_id]/@typeCode="COMP"		
			entryRelationship[specimen]/observation/entryRelationship[prnt_id]/observation		
			entryRelationship[specimen]/observation/entryRelationship[prnt_id]/observation/@classCode="OBS"		
			entryRelationship[specimen]/observation/entryRelationship[prnt_id]/observation/@moodCode="EVN"		
			entryRelationship[specimen]/observation/entryRelationship[prnt_id]/observation/code		
			entryRelationship[specimen]/observation/entryRelationship[prnt_id]/observation/code/@code="103.16187"		
			entryRelationship[specimen]/observation/entryRelationship[prnt_id]/observation/code/@codeSystem="1.2.36.1.2001.1001.101"		
			entryRelationship[specimen]/observation/entryRelationship[prnt_id]/observation/code/@codeSystemName	The value <b>SHOULD</b> be "NCTIS Data Components".  See <a href="#">CodeSystem OIDs</a> .	Optional CDA element.
entryRelationship[specimen]/observation/entryRelationship[prnt_id]/observation/code/@displayName="Parent Specimen Identifier"					
entryRelationship[specimen]/observation/entryRelationship[prnt_id]/observation/specimen/specimenRole/id			See <id> for available attributes.		
Test Specimen Detail (SPECIMEN) > Specimen Identifier > Container Identifier	Unique identifier given to the container in which the specimen is transported or processed.	0..1	entryRelationship[specimen]/observation/specimen/specimenRole/specimenPlayingEntity/ext:asSpecimenInContainer		See NEHTA CDA extension: <a href="#">Container</a>
			entryRelationship[specimen]/observation/specimen/specimenRole/specimenPlayingEntity/ext:asSpecimenInContainer/@classCode="CONT"		
			entryRelationship[specimen]/observation/specimen/specimenRole/specimenPlayingEntity/ext:asSpecimenInContainer/ext:container		
			entryRelationship[specimen]/observation/specimen/specimenRole/specimenPlayingEntity/ext:asSpecimenInContainer/ext:container/ext:id		See <id> for available attributes.

## Example 7.4. Test Specimen Detail (SPECIMEN) XML Fragment

<!-- This xml fragment is provided to demonstrate an example instance of each structured element in the CDA Mapping table. It is illustrative only. Logical model constraints on allowed combinations of child components are ignored in order to provide coverage of structured elements. This fragment cannot be treated as clinically valid. While the values in the fragment are conformant with the CDA Mapping table they are typically exaggerated to highlight the semantic meaning of the structured elements and may not be indicative of the expected values in a clinical document. While every effort has been taken to ensure that the examples are consistent with the message specification, where there are conflicts with the written message specification or schema, the specification or schema will take precedence. -->

```
<ClinicalDocument xmlns="urn:hl7-org:v3"
  xmlns:ext="http://ns.electronichealth.net.au/Ci/Cda/Extensions/3.0"
  ...
  <!-- Begin CDA Header -->
  ...
  <!-- End CDA Header -->

  <!-- Begin CDA Body -->
  <component>
    <structuredBody>
      ...
      <!-- Begin PATHOLOGY -->
      <component typeCode="COMP">
        <section classCode="DOCSECT" moodCode="EVN">
          ...
          <!-- Begin PATHOLOGY TEST RESULT -->
          <component>
            <section classCode="DOCSECT" moodCode="EVN">
              ...
              <entry>
                <observation classCode="OBS" moodCode="EVN">
                  ...
                  <!-- Begin Test Specimen Detail (SPECIMEN) -->
                  <entryRelationship typeCode="SUBJ">
                    <observation classCode="OBS" moodCode="EVN">
                      <!-- ID is used for system purposes such as matching -->
                      <id root="CCC0D55C-EFD0-11DF-BEA2-A6CCDFD72085" />
                      <code code="102.16156.220.2.1" codeSystem="1.2.36.1.2001.1001.101" codeSystemName="NCTIS Data Components" displayName="Specimen" />
                      <!-- Date and Time of Collection (Collection DateTime) -->
                      <effectiveTime value="201310201235+1000" />

                      <!-- Collection Procedure -->
                      <methodCode code="48635004" codeSystem="2.16.840.1.113883.6.96" codeSystemName="SNOMED CT"
                        displayName="Fine needle biopsy" />

                      <!-- Anatomical Site (ANATOMICAL LOCATION) :: Examples provided of all three allowed variants. These variants are mutually exclusive -->
                      <!-- Begin Example with complete SPECIFIC LOCATION -->
                      <!-- Begin SPECIFIC LOCATION -->
                      <!-- Name of Location (Anatomical Location Name) -->
                      <targetSiteCode code="51185008" codeSystem="2.16.840.1.113883.6.96" codeSystemName="SNOMED CT" displayName="thorax">

                      <!-- Begin Side -->
                      <qualifier>
                        <name code="272741003" codeSystem="2.16.840.1.113883.6.96" codeSystemName="SNOMED CT" displayName="Laterality" />
                        <value code="7771000" codeSystem="2.16.840.1.113883.6.96" codeSystemName="SNOMED CT" displayName="left" xsi:type="CD" />
                    
```



```

</qualifier>
<!-- End Side -->

</targetSiteCode>
<!-- End SPECIFIC LOCATION -->
<!-- End Example with complete SPECIFIC LOCATION -->

<!-- Begin Example with partial SPECIFIC LOCATION -->
<!-- Begin SPECIFIC LOCATION -->
<!-- Name of Location (Anatomical Location Name) -->
<targetSiteCode code="51185008" codeSystem="2.16.840.1.113883.6.96" codeSystemName="SNOMED CT" displayName="thorax" />
<!-- End SPECIFIC LOCATION -->
<!-- End Example with partial SPECIFIC LOCATION -->

<!-- Begin Example with Description -->
<targetSiteCode>
  <!-- Description (Anatomical Location Description) -->
  <originalText>Chest/Thorax</originalText>
</targetSiteCode>
<!-- End SPECIFIC LOCATION -->
<!-- End Example with Description -->
<!-- End Anatomical Site (ANATOMICAL LOCATION) -->

<!-- Begin Physical Details -->
<specimen>
  <specimenRole>
    <!-- Specimen Identifier -->
    <id root="1538103e-845b-4f86-95ed-33b62e7589d0" />

    <!-- Begin Physical Details (PHYSICAL PROPERTIES OF AN OBJECT) -->
    <specimenPlayingEntity>
      <!-- Specimen Tissue Type -->
      <code code="258442002" codeSystem="2.16.840.1.113883.6.96" codeSystemName="SNOMED CT" displayName="Fluid sample" />

      <!-- Begin Weight/Volume -->
      <quantity unit="mL" value="5" />
      <!-- End Weight/Volume -->

      <!-- Begin Description (Object Description) -->
      <desc xsi:type="ST">5 mL</desc>
      <!-- End Description (Object Description) -->

      <!-- Begin Container Identifier -->
      <ext:asSpecimenInContainer classCode="CONT">
        <ext:container>
          <ext:id extension="CNH45218964" root="CA54FD22-76B8-11E0-AC87-0EE34824019B" />
        </ext:container>
      </ext:asSpecimenInContainer>
      <!-- End Container Identifier -->

    </specimenPlayingEntity>
    <!-- End Physical Details (PHYSICAL PROPERTIES OF AN OBJECT) -->
  </specimenRole>
</specimen>
<!-- End Physical Details -->

<!-- Begin Anatomical Location Image -->
<entryRelationship typeCode="SPRT">
  <observationMedia classCode="OBS" moodCode="EVN">
    <id root="3953A078-0365-11E1-B90D-41D04724019B" />
    <value mediaType="image/jpeg" >
      <reference value="location.jpeg" />
    </value>
  </observationMedia>
</entryRelationship>

```

```
</observationMedia>
</entryRelationship>
<!-- End Anatomical Location Image -->

<!-- Begin Image -->
<entryRelationship typeCode="SPRT">
<observationMedia classCode="OBS" moodCode="EVN">
  <id root="1d64bb51-c5b3-4048-9a9f-e753f4e3c203" />
  <value mediaType="image/jpeg" >
    <reference value="specimen.jpeg" />
  </value>
</observationMedia>
</entryRelationship>
<!-- End Image -->

<!-- Begin Sampling Preconditions -->
<entryRelationship typeCode="COMP">
<observation classCode="OBS" moodCode="EVN">
  <code code="103.16171" codeSystem="1.2.36.1.2001.1001.101"
    codeSystemName="NCTIS Data Components" displayName="Sampling Preconditions" />
  <value code="16985007" codeSystem="2.16.840.1.113883.6.96" codeSystemName="SNOMED CT"
    displayName="Fasting" xsi:type="CD" />
</observation>
</entryRelationship>
<!-- End Sampling Preconditions -->

<!-- Begin Collection Setting -->
<entryRelationship typeCode="COMP">
<observation classCode="OBS" moodCode="EVN">
  <code code="103.16529" codeSystem="1.2.36.1.2001.1001.101"
    codeSystemName="NCTIS Data Components" displayName="Collection Setting" />
  <value xsi:type="ST">Pathology Clinic</value>
</observation>
</entryRelationship>
<!-- End Collection Setting -->

<!-- Begin Date and Time of Receipt (DateTime Received) -->
<entryRelationship typeCode="COMP">
<observation classCode="OBS" moodCode="EVN">
  <code code="103.11014" codeSystem="1.2.36.1.2001.1001.101"
    codeSystemName="NCTIS Data Components" displayName="DateTime Received" />
  <value value="201112141120+1000" xsi:type="TS" />
</observation>
</entryRelationship>
<!-- End Date and Time of Receipt (DateTime Received) -->

<!-- Begin Parent Specimen Identifier -->
<entryRelationship typeCode="COMP">
<observation classCode="OBS" moodCode="EVN">
  <code code="103.16187" codeSystem="1.2.36.1.2001.1001.101"
    codeSystemName="NCTIS Data Components" displayName="Parent Specimen Identifier" />
  <specimen>
    <specimenRole>
      <id root="7013b12a-f9d0-4197-9726-88a6803d4d13" />
    </specimenRole>
  </specimen>
</observation>
</entryRelationship>
<!-- End Parent Specimen Identifier -->

</observation>
</entryRelationship>
<!-- End Test Specimen Detail (SPECIMEN) -->
```

```
...
<!-- Begin Result Group (PATHOLOGY TEST RESULT GROUP) -->
<entryRelationship typeCode="COMP">
  <organizer classCode="BATTERY" moodCode="EVN">
    ...

    </organizer>
  </entryRelationship>
<!-- End Result Group (PATHOLOGY TEST RESULT GROUP) -->

...

<!-- Begin TEST REQUEST DETAILS -->
<entryRelationship inversionInd="true" typeCode="SUBJ">
  <act classCode="ACT" moodCode="EVN">
    ...

    </act>
  </entryRelationship>
<!-- End Test TEST REQUEST DETAILS -->

...

  </observation>
</entry>
</section>
</component>
<!-- End PATHOLOGY TEST RESULT -->

...

</section>
</component>
  <!-- End PATHOLOGY -->

...

  </structuredBody>
</component>
<!-- End CDA Body -->
</ClinicalDocument>
```

### 7.1.1.1.2 Result Group (PATHOLOGY TEST RESULT GROUP)

#### Identification



<b>Name</b>	Result Group (PATHOLOGY TEST RESULT GROUP)
<b>Metadata Type</b>	Data Group
<b>Identifier</b>	DG-16469

#### Relationships

##### Parent

Data Type	Name	Occurrences (child within parent)
	<a href="#">PATHOLOGY TEST RESULT</a>	0..*

##### Children

Data Type	Name	Occurrence
	<a href="#">Individual Pathology Test Result Value Reference Ranges (REFERENCE RANGE DETAILS)</a>	0..1
	<a href="#">Result Group Specimen Detail (SPECIMEN)</a>	0..1

## CDA R-MIM Representation

Figure 7.5 Result Group (PATHOLOGY TEST RESULT GROUP) shows a subset of the CDA R-MIM containing those classes being referred to in the CDA Mapping. This data component maps to CDA Body elements.

Result Group (PATHOLOGY TEST RESULT GROUP) is represented by an Organizer class related to its containing Observation class by an entryRelationship. The code attribute of that Organizer class represents Pathology Test Result Group Name.

Each INDIVIDUAL PATHOLOGY TEST RESULT data group is represented by an Observation class related to the containing Organizer class by a component. The code attribute of that Observation (INDIVIDUAL PATHOLOGY TEST RESULT) class represents Individual Pathology Test Result Name and the value attribute represents Individual Pathology Test Result Value.

There are two Act classes related to the containing Observation (INDIVIDUAL PATHOLOGY TEST RESULT) class by an entryRelationship: Individual Pathology Test Result Comment and Individual Pathology Test Result Reference Range Guidance. Individual Pathology Test Result Status is represented by an Observation class related to the containing Observation (INDIVIDUAL PATHOLOGY TEST RESULT) class by an entryRelationship.

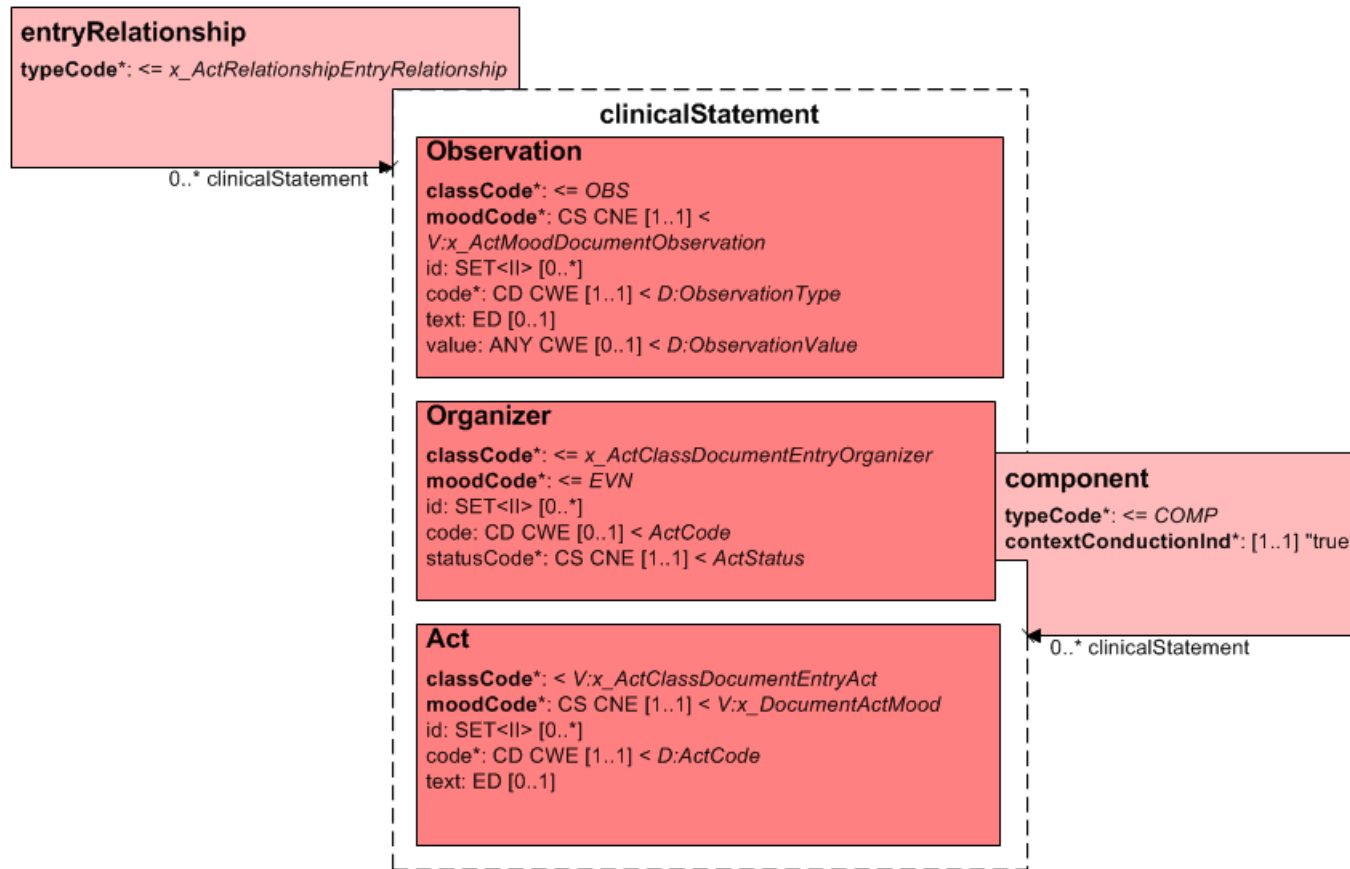

Figure 7.5. Result Group (PATHOLOGY TEST RESULT GROUP)

## CDA Mapping

NEHTA SCS Data Component	Data Component Definition	Card	CDA Schema Data Element	Vocab	Comments
<b>CDA Body Level 3 Data Elements</b>			Context: ClinicalDocument/component/structuredBody/component[pathology]/section/component[path_test]/section/entry[path_test_res]/observation/		
Result Group (PATHOLOGY TEST RESULT GROUP)	A group of results that form all or part of a recognisable pathology test.	0..*	entryRelationship[res_gp]/@typeCode="COMP"		
			entryRelationship[res_gp]/organizer		
			entryRelationship[res_gp]/organizer/@classCode="BATTERY"		
			entryRelationship[res_gp]/organizer/@moodCode="EVN"		
			entryRelationship[res_gp]/organizer/id	UUID This is a technical identifier that is used for system purposes such as matching. If a suitable internal key is not available, a UUID <b>MAY</b> be used.	See <id> for available attributes.
			entryRelationship[res_gp]/organizer/statusCode/@code="completed"		Required CDA element.
Result Group (PATHOLOGY TEST RESULT GROUP) > Pathology Test Result Group Name	The name of a group of pathology test results.	1..1	entryRelationship[res_gp]/organizer/code	The code <b>SHOULD</b> be from the set of codes recommended for pathology terminology by the Royal College of Pathologists of Australasia which can be found at the <a href="https://www.nehta.gov.au/implementation-resources/terminology-access/#pathology">NEHTA Terminology Access</a> <sup>6</sup> website.	See <code> for available attributes.

<sup>6</sup> <https://www.nehta.gov.au/implementation-resources/terminology-access/#pathology>

NEHTA SCS Data Component	Data Component Definition	Card	CDA Schema Data Element	Vocab	Comments
Result Group (PATHOLOGY TEST RESULT GROUP) > <b>Result (INDIVIDUAL PATHOLOGY TEST RESULT)</b>	Specific detailed result of a pathology test, including both the value of the result item, and additional information that may be useful for clinical interpretation.	1..*	entryRelationship[res_gp]/organizer/component[ind_res]/		
			entryRelationship[res_gp]/organizer/component[ind_res]/observation		
			entryRelationship[res_gp]/organizer/component[ind_res]/observation/@classCode="OBS"		
			entryRelationship[res_gp]/organizer/component[ind_res]/observation/@moodCode="EVN"		
			entryRelationship[res_gp]/organizer/component[ind_res]/observation/id	UUID  This is a technical identifier that is used for system purposes such as matching. If a suitable internal key is not available, a UUID <b>MAY</b> be used.	See <id> for available attributes.
Result Group (PATHOLOGY TEST RESULT GROUP) > Result (INDIVIDUAL PATHOLOGY TEST RESULT) > <b>Individual Pathology Test Result Name</b>	The name of an individual pathology test result.	1..1	entryRelationship[res_gp]/organizer/component[ind_res]/observation/code	The code <b>SHOULD</b> be from the set of codes recommended for pathology terminology by the Royal College of Pathologists of Australasia which can be found at the <a href="#">NEHTA Terminology Access</a> website.	See <code> for available attributes.
Result Group (PATHOLOGY TEST RESULT GROUP) > Result (INDIVIDUAL PATHOLOGY TEST RESULT) > <b>Result Value (INDIVIDUAL PATHOLOGY TEST RESULT VALUE)</b>	Value of the result, with reference range information.	0..1	n/a		This logical NEHTA data component has no mapping to CDA.  The cardinality of this component propagates to its children.
Result Group (PATHOLOGY TEST RESULT GROUP) > Result (INDIVIDUAL PATHOLOGY TEST RESULT) > Result Value (INDIVIDUAL PATHOLOGY TEST RESULT VALUE) > <b>Individual Pathology Test Result Value</b>	The actual value of the result.	1..1	entryRelationship[res_gp]/organizer/component[ind_res]/observation/value		Although <b>value</b> is of datatype ANY only CD, PQ, BL, ST, INT, RTO, IVL_PQ or PPD <b>SHALL</b> be used.

<sup>7</sup> <https://www.nehta.gov.au/implementation-resources/terminology-access/#pathology>



NEHTA SCS Data Component	Data Component Definition	Card	CDA Schema Data Element	Vocab	Comments
Result Group (PATHOLOGY TEST RESULT GROUP) > Result (INDIVIDUAL PATHOLOGY TEST RESULT) > Result Value (INDIVIDUAL PATHOLOGY TEST RESULT VALUE) > <b>Individual Pathology Test Result Value Reference Ranges (REFERENCE RANGE DETAILS)</b>	One or more reference ranges applicable to the Individual Pathology Test Result Value.	0..1	See: <a href="#">Individual Pathology Test Result Value Reference Ranges (REFERENCE RANGE DETAILS)</a>		
Result Group (PATHOLOGY TEST RESULT GROUP) > Result (INDIVIDUAL PATHOLOGY TEST RESULT) > <b>Individual Pathology Test Result Comment</b>	Comments that may include statements about significant, unexpected or unreliable values, or information about the source of the value where this may be relevant to the interpretation of the result.	0..*	entryRelationship[res_gp]/organizer/component[ind_res]/observation/entryRelationship[res_cmt]/ <b>@typeCode="COMP"</b> entryRelationship[res_gp]/organizer/component[ind_res]/observation/entryRelationship[res_cmt]/ <b>act</b> entryRelationship[res_gp]/organizer/component[ind_res]/observation/entryRelationship[res_cmt]/ act/ <b>@classCode="INFRM"</b> entryRelationship[res_gp]/organizer/component[ind_res]/observation/entryRelationship[res_cmt]/ act/ <b>@moodCode="EVN"</b> entryRelationship[res_gp]/organizer/component[ind_res]/observation/entryRelationship[res_cmt]/act/ <b>code</b> entryRelationship[res_gp]/organizer/component[ind_res]/observation/entryRelationship[res_cmt]/act/ code/ <b>@code="281296001"</b> entryRelationship[res_gp]/organizer/component[ind_res]/observation/entryRelationship[res_cmt]/act/ code/ <b>@codeSystem="2.16.840.1.113883.6.96"</b> entryRelationship[res_gp]/organizer/component[ind_res]/observation/entryRelationship[res_cmt]/act/ code/ <b>@codeSystemName</b> entryRelationship[res_gp]/organizer/component[ind_res]/observation/entryRelationship[res_cmt]/act/ code/ <b>@displayName="result comments"</b> entryRelationship[res_gp]/organizer/component[ind_res]/observation/entryRelationship[res_cmt]/ act/ <b>text:ST</b>	The value <b>SHOULD</b> be "SNOMED CT".  See <a href="#">CodeSystem OIDs</a> .	Optional CDA element.

NEHTA SCS Data Component	Data Component Definition	Card	CDA Schema Data Element	Vocab	Comments
Result Group (PATHOLOGY TEST RESULT GROUP) > Result (INDIVIDUAL PATHOLOGY TEST RESULT) > <b>Individual Pathology Test Result Reference Range Guidance</b>	Additional advice on the applicability of the reference range.	0..1	entryRelationship[res_gp]/organizer/component[ind_res]/observation/entryRelationship[ref_guide]/@typeCode="COMP"		
			entryRelationship[res_gp]/organizer/component[ind_res]/observation/entryRelationship[ref_guide]/act		
			entryRelationship[res_gp]/organizer/component[ind_res]/observation/entryRelationship[ref_guide]/act/@classCode="INFRM"		
			entryRelationship[res_gp]/organizer/component[ind_res]/observation/entryRelationship[ref_guide]/act/@moodCode="EVN"		
			entryRelationship[res_gp]/organizer/component[ind_res]/observation/entryRelationship[ref_guide]/act/code		
			entryRelationship[res_gp]/organizer/component[ind_res]/observation/entryRelationship[ref_guide]/act/code/@code="281298000"		
			entryRelationship[res_gp]/organizer/component[ind_res]/observation/entryRelationship[ref_guide]/act/code/@codeSystem="2.16.840.1.113883.6.96"		
			entryRelationship[res_gp]/organizer/component[ind_res]/observation/entryRelationship[ref_guide]/act/code/@codeSystemName	The value <b>SHOULD</b> be "SNOMED CT".  See <a href="#">CodeSystem OIDs</a> .	Optional CDA element.
			entryRelationship[res_gp]/organizer/component[ind_res]/observation/entryRelationship[ref_guide]/act/code/@displayName="reference range comments"		
entryRelationship[res_gp]/organizer/component[ind_res]/observation/entryRelationship[ref_guide]/act/text:ST					

NEHTA SCS Data Component	Data Component Definition	Card	CDA Schema Data Element	Vocab	Comments
Result Group (PATHOLOGY TEST RESULT GROUP) > Result (INDIVIDUAL PATHOLOGY TEST RESULT) > <b>Individual Pathology Test Result Status</b>	The status of the result value.	1..1	entryRelationship[res_gp]/organizer/component[ind_res]/observation/entryRelationship[res_stat]/@typeCode="COMP"		
			entryRelationship[res_gp]/organizer/component[ind_res]/observation/entryRelationship[res_stat]/observation		
			entryRelationship[res_gp]/organizer/component[ind_res]/observation/entryRelationship[res_stat]/observation/@classCode="OBS"		
			entryRelationship[res_gp]/organizer/component[ind_res]/observation/entryRelationship[res_stat]/observation/@moodCode="EVN"		
			entryRelationship[res_gp]/organizer/component[ind_res]/observation/entryRelationship[res_stat]/observation/code		
			entryRelationship[res_gp]/organizer/component[ind_res]/observation/entryRelationship[res_stat]/observation/code/@code="308552006"		
			entryRelationship[res_gp]/organizer/component[ind_res]/observation/entryRelationship[res_stat]/observation/code/@codeSystem="2.16.840.1.113883.6.96"		
			entryRelationship[res_gp]/organizer/component[ind_res]/observation/entryRelationship[res_stat]/observation/code/@codeSystemName	The value <b>SHOULD</b> be "SNOMED CT".  See <a href="#">CodeSystem OIDs</a> .	Optional CDA element.
			entryRelationship[res_gp]/organizer/component[ind_res]/observation/entryRelationship[res_stat]/observation/code/@displayName="report status"		
			entryRelationship[res_stat]/observation/value:CD	<a href="#">HL7: Result Status</a>	See <code> for available attributes.
Result Group (PATHOLOGY TEST RESULT GROUP) > <b>Result Group Specimen Detail (SPECIMEN)</b>	Details about the individual specimen to which these result group test results refer, where testing of multiple specimens is required.	0..1	See: <a href="#">Result Group Specimen Detail (SPECIMEN)</a>		

## Example 7.5. Result Group (PATHOLOGY TEST RESULT GROUP) XML Fragment

<!-- This xml fragment is provided to demonstrate an example instance of each structured element in the CDA Mapping table. It is illustrative only. Logical model constraints on allowed combinations of child components are ignored in order to provide coverage of structured elements. This fragment cannot be treated as clinically valid. While the values in the fragment are conformant with the CDA Mapping table they are typically exaggerated to highlight the semantic meaning of the structured elements and may not be indicative of the expected values in a clinical document. While every effort has been taken to ensure that the examples are consistent with the message specification, where there are conflicts with the written message specification or schema, the specification or schema will take precedence. -->

```
<ClinicalDocument xmlns="urn:hl7-org:v3"
  xmlns:ext="http://ns.electronichealth.net.au/Ci/Cda/Extensions/3.0"
  ...
  <!-- Begin CDA Header -->
  ...
  <!-- End CDA Header -->

  <!-- Begin CDA Body -->
  <component>
    <structuredBody>
      ...
      <!-- Begin PATHOLOGY -->
      <component typeCode="COMP">
        <section classCode="DOCSECT" moodCode="EVN">
          ...
          <!-- Begin PATHOLOGY TEST RESULT -->
          <component>
            <section classCode="DOCSECT" moodCode="EVN">
              ...
              <entry>
                <observation classCode="OBS" moodCode="EVN">
                  ...
                  <!-- Begin Test Specimen Detail (SPECIMEN) -->
                  <entryRelationship typeCode="SUBJ">
                    <observation classCode="OBS" moodCode="EVN">
                      ...
                    </observation>
                  </entryRelationship>
                  <!-- End Test Specimen Detail (SPECIMEN) -->
                ...
              </entry>
            </section>
          </component>
          <!-- Begin Result Group (PATHOLOGY TEST RESULT GROUP) -->
          <entryRelationship typeCode="COMP">
            <organizer classCode="BATTERY" moodCode="EVN">
              <id root="9BE931D2-F085-11E0-9831-1E7C4824019B" />

              <!-- Pathology Test Result Group Name -->
              <code code="18719-5" codeSystem="2.16.840.1.113883.6.1" codeSystemName="LOINC"
                displayName="Chemistry studies (set)" />
              <statusCode code="completed" />

              <!-- Begin Result (INDIVIDUAL PATHOLOGY TEST RESULT) -->
              <component>
```

```

<observation classCode="OBS" moodCode="EVN">
  <id root="3802BA7A-F086-11E0-8A74-147D4824019B" />
  <!-- Individual Pathology Test Result Name -->
  <code code="14682-9" codeSystem="2.16.840.1.113883.6.1" codeSystemName="LOINC" displayName="Serum Creatinine" />
  <!-- Individual Pathology Test Result Value -->
  <value unit="mmol/L" value="0.06" xsi:type="PQ" />

  ...

  <!-- Begin Individual Pathology Test Result Comment -->
  <entryRelationship typeCode="COMP">
    <act classCode="INFRM" moodCode="EVN">
      <code code="281296001" codeSystem="2.16.840.1.113883.6.96"
        codeSystemName="SNOMED CT"
        displayName="result comments" />
      <text>Within normal range.</text>
    </act>
  </entryRelationship>
  <!-- End Individual Pathology Test Result Comment -->

  <!-- Begin Individual Pathology Test Result Reference Range Guidance -->
  <entryRelationship typeCode="COMP">
    <act classCode="INFRM" moodCode="EVN">
      <code code="281298000" codeSystem="2.16.840.1.113883.6.96"
        codeSystemName="SNOMED CT"
        displayName="reference range comments" />
      <text xsi:type="ST">Within normal range +/- 5%.</text>
    </act>
  </entryRelationship>
  <!-- End Individual Pathology Test Result Reference Range Guidance -->

  <!-- Begin Individual Pathology Test Result Status -->
  <entryRelationship typeCode="COMP">
    <observation classCode="OBS" moodCode="EVN">
      <code code="308552006" codeSystem="2.16.840.1.113883.6.96"
        codeSystemName="SNOMED CT"
        displayName="report status" />
      <value code="F"
        codeSystem="2.16.840.1.113883.12.123"
        codeSystemName="HL7 Result Status"
        displayName="Final results; results stored and verified. Can only be changed with a corrected result."
        xsi:type="CD" />
    </observation>
  </entryRelationship>
  <!-- End Individual Pathology Test Result Status -->

  <!-- Begin REFERENCE RANGE DETAILS -->
  <referenceRange typeCode="REFV">
    <!-- Begin REFERENCE RANGE -->
    <observationRange classCode="OBS" moodCode="EVN.CRT">
      ...
    </observationRange>
    <!-- End REFERENCE RANGE -->
  </referenceRange>
  <!-- End REFERENCE RANGE DETAILS -->

</observation>
</component>
<!-- Begin Result (INDIVIDUAL PATHOLOGY TEST RESULT) -->

<!-- Begin Result Group Specimen Detail (SPECIMEN) -->
<component>

```

```
<observation classCode="OBS" moodCode="EVN">
  ...
  </observation>
</component>
<!-- End Result Group Specimen Detail (SPECIMEN) -->

</organizer>
</entryRelationship>
<!-- End Result Group (PATHOLOGY TEST RESULT GROUP) -->

...

<!-- Begin TEST REQUEST DETAILS -->
<entryRelationship inversionInd="true" typeCode="SUBJ">
  <act classCode="ACT" moodCode="EVN">
    ...
  </act>
</entryRelationship>
<!-- End Test TEST REQUEST DETAILS -->

...

</observation>
</entry>
</section>
</component>
<!-- End PATHOLOGY TEST RESULT -->

...

</section>
</component>
<!-- End PATHOLOGY -->

...

</structuredBody>
</component>
<!-- End CDA Body -->
</ClinicalDocument>
```

### 7.1.1.1.2.1 Individual Pathology Test Result Value Reference Ranges (REFERENCE RANGE DETAILS)

#### Identification

<b>Name</b>	Individual Pathology Test Result Value Reference Ranges (REFERENCE RANGE DETAILS)
<b>Metadata Type</b>	Data Group
<b>Identifier</b>	DG-16325

#### Relationships

##### Parent

Data Type	Name	Occurrences (child within parent)
	<a href="#">Result Group (PATHOLOGY TEST RESULT GROUP)</a>	0..1

## CDA R-MIM Representation

Figure 7.6 Individual Pathology Test Result Value Reference Ranges (REFERENCE RANGE DETAILS) shows a subset of the CDA R-MIM containing those classes being referred to in the CDA Mapping. This data component maps to CDA Body elements.

The REFERENCE RANGE DETAILS data group is represented by an ObservationRange class that is related to its containing Observation class by a referenceRange relationship. Normal Status is represented by the interpretationCode attribute of the containing Observation class. The code attribute of the ObservationRange class represents Reference Range Meaning, and the value attribute represents Reference Range.

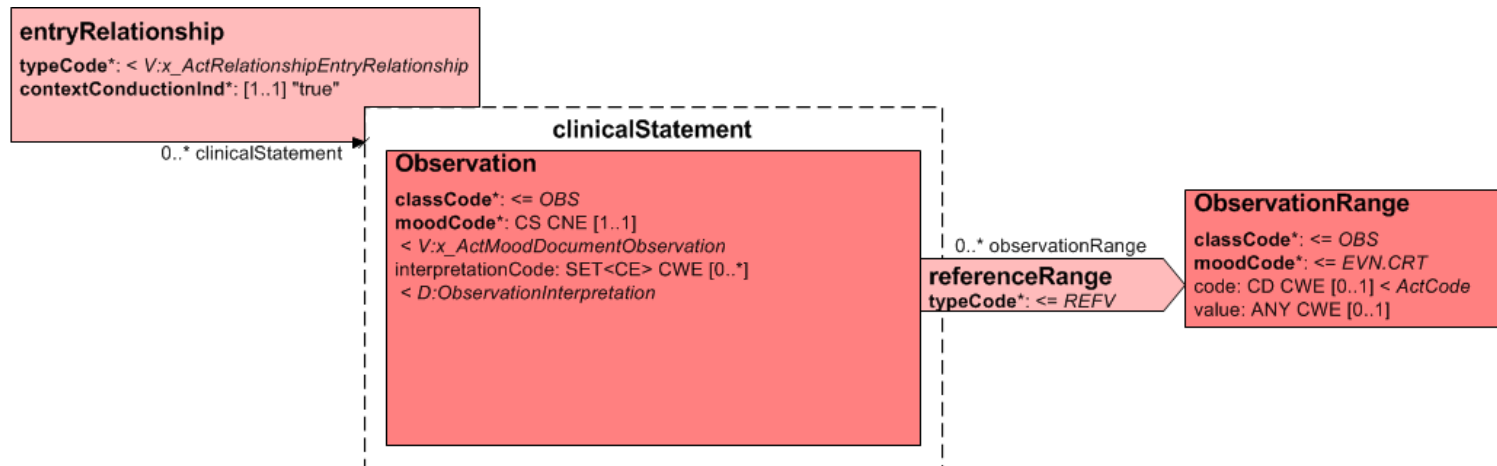

**Figure 7.6. Individual Pathology Test Result Value Reference Ranges (REFERENCE RANGE DETAILS)**



## CDA Mapping



## Note

NS = In the absence of national standard code sets, the code sets used **SHALL** be registered code sets, i.e. registered through the [HL7 code set registration procedure](#)<sup>8</sup> with an appropriate object identifier (OID), and **SHALL** be publicly available.

When national standard code sets become available, they **SHALL** be used and the non-standard code sets **SHALL** be deprecated.

NEHTA SCS Data Component	Data Component Definition	Card	CDA Schema Data Element	Vocab	Comments
<b>CDA Body Level 3 Data Elements</b>			Context: ClinicalDocument/component/structuredBody/component[pathology]/section/component[path_test]/section/entry[path_test_res]/observation/entryRelationship[res_gp]/organizer/component[ind_res]/observation/		
<b>Individual Pathology Test Result Value Reference Ranges (REFERENCE RANGE DETAILS)</b>	One or more reference ranges applicable to the Individual Pathology Test Result Value.	0..1	n/a		This logical NEHTA data component has no mapping to CDA.  See <a href="#">Known Issues</a> .
Individual Pathology Test Result Value Reference Ranges (REFERENCE RANGE DETAILS) > <b>Normal Status</b>	An indication of the degree of diagnostically significant abnormality of the value, based on available clinical information (including but not limited to the reference range).	0..1	<b>interpretationCode</b>	<a href="#">HL7 V3: Observation-InterpretationNormality</a>	See <code> for available attributes.
Individual Pathology Test Result Value Reference Ranges (REFERENCE RANGE DETAILS) > <b>REFERENCE RANGE</b>	A named range to be associated with any quantity datum.	0..*	<b>referenceRange/@typeCode="REFV"</b>		
			referenceRange/observationRange		
			referenceRange/observationRange/@classCode="OBS"		
			referenceRange/observationRange/@moodCode="EVN.CRT"		
Individual Pathology Test Result Value Reference Ranges (REFERENCE RANGE DETAILS) > <b>REFERENCE RANGE &gt; Reference Range Meaning</b>	Term whose value indicates the meaning of this range.	1..1	referenceRange/observationRange/code	NS	See <code> for available attributes.
Individual Pathology Test Result Value Reference Ranges (REFERENCE RANGE DETAILS) > <b>REFERENCE RANGE &gt; Reference Range</b>	The data range for the associated Reference Range Meaning data element.	1..1	referenceRange/observationRange/value:IVL_PQ		

<sup>8</sup> <http://www.hl7.org/oid/index.cfm?ref=footer>



```
<!-- Begin Reference Range -->
<value xsi:type="IVL_PQ">
  <low value="0.04" />
  <high value="0.11" />
</value>
<!-- End Reference Range -->

</observationRange>
<!-- End REFERENCE RANGE -->
</referenceRange>
<!-- End Individual Pathology Test Result Value Reference Ranges (REFERENCE RANGE DETAILS) -->

</observation>
</component>
<!-- Begin Result (INDIVIDUAL PATHOLOGY TEST RESULT) -->

...

</organizer>
</entryRelationship>
<!-- End Result Group (PATHOLOGY TEST RESULT GROUP) -->

...

</observation>
</entry>
</section>
</component>
<!-- End PATHOLOGY TEST RESULT -->
...

</section>
</component>
<!-- End PATHOLOGY -->

...

</structuredBody>
</component>
<!-- End CDA Body -->
</ClinicalDocument>
```

### 7.1.1.1.2.2 Result Group Specimen Detail (SPECIMEN)

#### Identification

Name	Result Group Specimen Detail (SPECIMEN)
Metadata Type	Data Group
Identifier	DG-16156

#### Relationships

##### Parent

Data Type	Name	Occurrences (child within parent)
	<a href="#">Result Group (PATHOLOGY TEST RESULT GROUP)</a>	0..1

## CDA R-MIM Representation

Figure 7.7 Result Group Specimen Detail (SPECIMEN) shows a subset of the CDA R-MIM containing those classes being referred to in the CDA Mapping. This data component maps to CDA Body elements.

The Result Group Specimen Detail (SPECIMEN) data group is represented by an Observation class that is related to its containing Section class by a component. The methodCode attribute of that Observation (SPECIMEN) class represents Collection Procedure, the effectiveTime attribute represents Collection DateTime, and targetSiteCode represents the ANATOMICAL LOCATION data elements.

Specimen Identifier is represented by the id attribute of a specimenRole which is related to its containing Observation (Pathology Test Result Name) class by a specimen participation. PHYSICAL PROPERTIES OF AN OBJECT is represented by a specimenPlayingEntity of the containing specimenRole. The code attribute of that specimenPlayingEntity represents Specimen Tissue Type, the quantity attribute represents Weight or Volume, and the desc attribute represents Object Description. Container Identifier is represented by the Container NEHTA CDA extension.

Anatomical Location Image and Image are both represented by a supporting ObservationMedia class related to the containing Observation (SPECIMEN) class by an entryRelationship.

There are four component Observation classes related to the containing Observation (SPECIMEN) class by entryRelationships: Sampling Preconditions, Collection Setting, DateTime Received, and Parent Specimen Identifier.

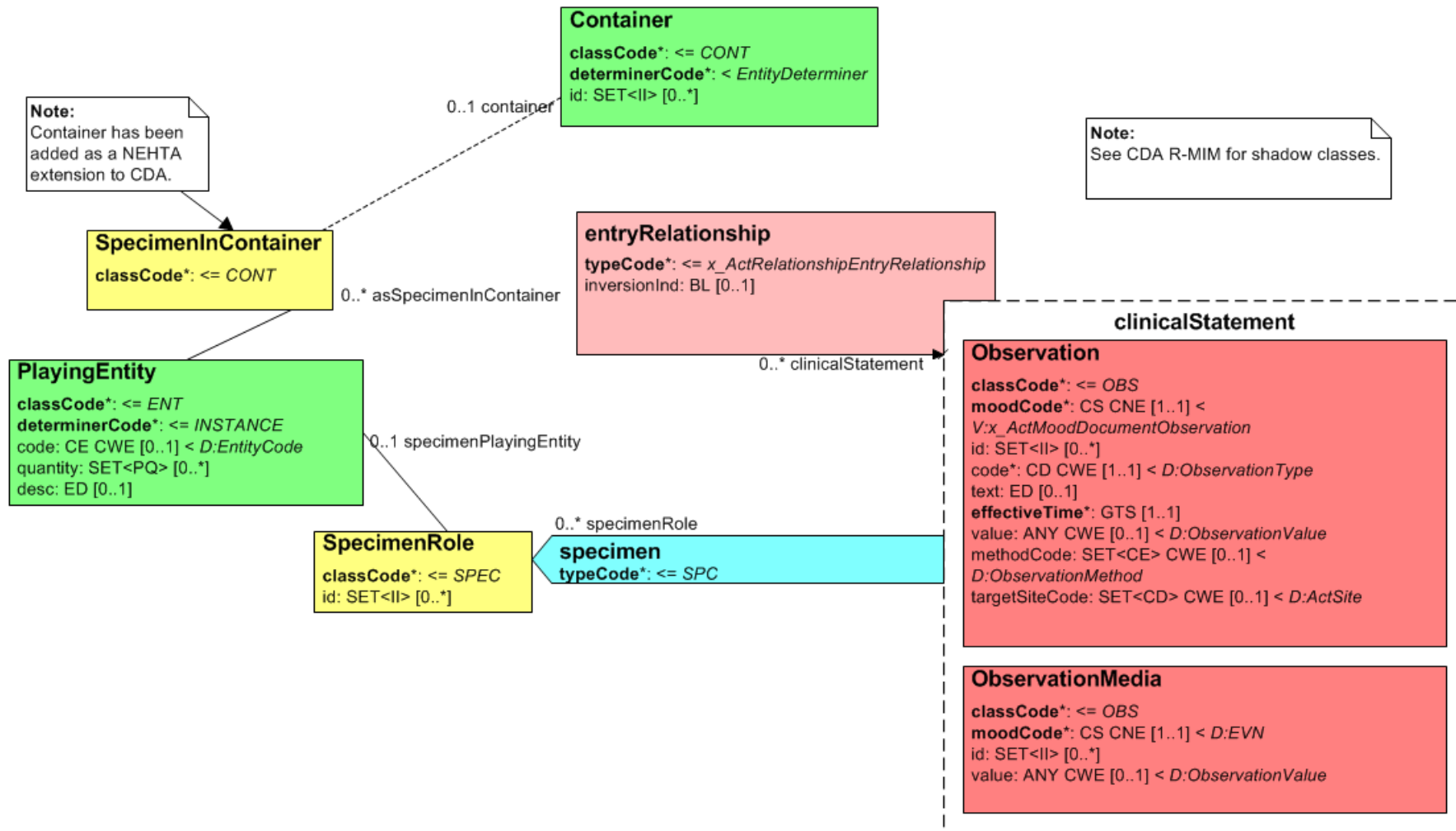

Figure 7.7. Result Group Specimen Detail (SPECIMEN)

## CDA Mapping



## Note

NS = In the absence of national standard code sets, the code sets used **SHALL** be registered code sets, i.e. registered through the [HL7 code set registration procedure](#)<sup>9</sup> with an appropriate object identifier (OID), and **SHALL** be publicly available.

When national standard code sets become available, they **SHALL** be used and the non-standard code sets **SHALL** be deprecated.

NEHTA SCS Data Component	Data Component Definition	Card	CDA Schema Data Element	Vocab	Comments
<b>CDA Body Level 3 Data Elements</b>			ClinicalDocument/component/structuredBody/component[pathology]/section/component[path_test]/section/entry[path_test_res]/observation/entryRelationship[res_gp]/organizer/		
<b>Result Group Specimen Detail (SPECIMEN)</b>	Details about the individual specimen to which these result group test results refer, where testing of multiple specimens is required.	0..1	<b>component[gp_specimen]</b>		
			component[gp_specimen]/ <b>observation</b>		
			component[gp_specimen]/observation/@ <b>classCode</b> ="OBS"		
			component[gp_specimen]/observation/@ <b>moodCode</b> ="EVN"		
			component[gp_specimen]/observation/ <b>code</b>		
			component[gp_specimen]/observation/code/@ <b>code</b> ="102.16156.220.2.2"		
			component[gp_specimen]/observation/code/@ <b>codeSystem</b> ="1.2.36.1.2001.1001.101"		
			component[gp_specimen]/observation/code/@ <b>codeSystemName</b>	The value <b>SHOULD</b> be "NCTIS Data Components".  See <a href="#">CodeSystem OIDs</a> .	Optional CDA element.
			component[gp_specimen]/observation/code/@ <b>displayName</b> ="Specimen"		
Result Group Specimen Detail (SPECIMEN) > <b>Specimen Tissue Type</b>	The type of specimen to be collected.	0..1	component[gp_specimen]/observation/specimen/specimenRole/specimenPlayingEntity/ <b>code</b>	NS	See <code> for available attributes.
Result Group Specimen Detail (SPECIMEN) > <b>Collection Procedure</b>	The method of collection to be used.	0..1	component[gp_specimen]/observation/ <b>methodCode</b>	NS	See <code> for available attributes.

<sup>9</sup> <http://www.hl7.org/oid/index.cfm?ref=footer>

NEHTA SCS Data Component	Data Component Definition	Card	CDA Schema Data Element	Vocab	Comments
Result Group Specimen Detail (SPECIMEN) > Anatomical Site (ANATOMICAL LOCATION)	The anatomical site from where the specimen was taken.	0..*	n/a	Each instance of Anatomical Site (ANATOMICAL LOCATION) <b>SHALL</b> contain either one instance of SPECIFIC LOCATION or one instance of Anatomical Location Description.	This logical NEHTA data component has no mapping to CDA.  The cardinality of this component propagates to its children.
Result Group Specimen Detail (SPECIMEN) > Anatomical Site (ANATOMICAL LOCATION) > SPECIFIC LOCATION	Specific and identified anatomical location.	0..1	n/a		This logical NEHTA data component has no mapping to CDA.  The cardinality of this component propagates to its children.
Result Group Specimen Detail (SPECIMEN) > Anatomical Site (ANATOMICAL LOCATION) > SPECIFIC LOCATION > Anatomical Location Name	The name of the anatomical location.	0..1	component[gp_specimen]/observation/targetSiteCode	SNOMED CT-AU:  • 32570061000036105  Body structure foundation reference set	See <code> for available attributes.
Result Group Specimen Detail (SPECIMEN) > Anatomical Site (ANATOMICAL LOCATION) > SPECIFIC LOCATION > Side	The laterality of the anatomical location.	0..1	component[gp_specimen]/observation/targetSiteCode/qualifier		
			component[gp_specimen]/observation/targetSiteCode/qualifier/name		
			component[gp_specimen]/observation/targetSiteCode/qualifier/name/@code="272741003"		
			component[gp_specimen]/observation/targetSiteCode/qualifier/name/@codeSystem="2.16.840.1.113883.6.96"		
			component[gp_specimen]/observation/targetSiteCode/qualifier/name/@codeSystemName	The value <b>SHOULD</b> be "SNOMED CT".  See <a href="#">CodeSystem OIDs</a> .	Optional CDA element.
			component[gp_specimen]/observation/targetSiteCode/qualifier/name/@displayName="Laterality"		
			component[gp_specimen]/observation/targetSiteCode/qualifier/value	SNOMED CT-AU:  • 32570611000036103  Laterality reference set	See <code> for available attributes.



NEHTA SCS Data Component	Data Component Definition	Card	CDA Schema Data Element	Vocab	Comments
Result Group Specimen Detail (SPECIMEN) > Anatomical Site (ANATOMICAL LOCATION) > <b>Anatomical Location Description</b>	Description of the anatomical location.	0..1	component[gp_specimen]/observation/targetSiteCode/ <b>originalText</b>		Anatomical Location Description is an instance of targetSiteCode with only an originalText element.
Result Group Specimen Detail (SPECIMEN) > Anatomical Site (ANATOMICAL LOCATION) > <b>Anatomical Location Image</b>	An image or images used to identify a location.	0..*	component[gp_specimen]/observation/entryRelationship[ana_im]/@typeCode="SPRT"		The image may or may not be attested to and is therefore mapped to observationMedia.
			component[gp_specimen]/observation/entryRelationship[ana_im]/ <b>observationMedia</b>		
			component[gp_specimen]/observation/entryRelationship[ana_im]/observationMedia/@classCode="OBS"		
			component[gp_specimen]/observation/entryRelationship[ana_im]/observationMedia/@moodCode="EVN"		
			component[gp_specimen]/observation/entryRelationship[ana_im]/observationMedia/id	UUID	See <id> for available attributes.  This is a technical identifier that is used for system purposes such as matching. If a suitable internal key is not available, a UUID <b>MAY</b> be used.
component[gp_specimen]/observation/entryRelationship[ana_im]/observationMedia/value					
Result Group Specimen Detail (SPECIMEN) > <b>Physical Details (PHYSICAL PROPERTIES OF AN OBJECT)</b>	Record of physical details, such as weight and dimensions, of a body part, device, lesion or specimen.	0..*	component[gp_specimen]/observation/ <b>specimen/specimenRole/specimenPlayingEntity</b>		
Result Group Specimen Detail (SPECIMEN) > Physical Details (PHYSICAL PROPERTIES OF AN OBJECT) > <b>Weight</b>	Property of a body – commonly, but inadequately, defined as the quantity of matter in it – to which its inertia is ascribed, and expressed as the weight of the body divided by the acceleration due to gravity.	0..1	component[gp_specimen]/observation/specimen/specimenRole/specimenPlayingEntity/ <b>quantity:PQ</b>		Either Weight or Volume <b>SHALL</b> be present. Weight and Volume <b>SHALL</b> be mutually exclusive.
Result Group Specimen Detail (SPECIMEN) > Physical Details (PHYSICAL PROPERTIES OF AN OBJECT) > <b>DI-MENSIONS</b>	The dimensions of the object.	0..1	n/a		This logical NEHTA data component has no mapping to CDA.  The cardinality of this component propagates to its children.

NEHTA SCS Data Component	Data Component Definition	Card	CDA Schema Data Element	Vocab	Comments
Result Group Specimen Detail (SPECIMEN) > Physical Details (PHYSICAL PROPERTIES OF AN OBJECT) > DIMENSIONS > <b>Volume</b>	Size, measure or amount of anything in three dimensions; space occupied by a body or substance measured in cubic units.	0..1	component[gp_specimen]/observation/specimen/specimenRole/specimenPlayingEntity/ <b>quantity:PQ</b>		Either Weight or Volume <b>SHALL</b> be present. Weight and Volume <b>SHALL</b> be mutually exclusive.
Result Group Specimen Detail (SPECIMEN) > Physical Details (PHYSICAL PROPERTIES OF AN OBJECT) > <b>Description (Object Description)</b>	A description of the physical characteristics of the object other than weight and volume.	0..1	component[gp_specimen]/observation/specimen/specimenRole/specimenPlayingEntity/ <b>desc:ST</b>		
Result Group Specimen Detail (SPECIMEN) > Physical Details (PHYSICAL PROPERTIES OF AN OBJECT) > <b>Image</b>	A picture of the object.	0..1	component[gp_specimen]/observation/ <b>entryRelationship[spec_im]/@typeCode="SPRT"</b>		The image may or may not be attested to and is therefore mapped to observationMedia.
			component[gp_specimen]/observation/ <b>entryRelationship[spec_im]/observationMedia</b>		
			component[gp_specimen]/observation/ <b>entryRelationship[spec_im]/observationMedia/@classCode="OBS"</b>		
			component[gp_specimen]/observation/ <b>entryRelationship[spec_im]/observationMedia/@moodCode="EVN"</b>		
			component[gp_specimen]/observation/ <b>entryRelationship[spec_im]/observationMedia/id</b>	UUID  This is a technical identifier that is used for system purposes such as matching. If a suitable internal key is not available, a UUID <b>MAY</b> be used.	
			component[gp_specimen]/observation/ <b>entryRelationship[spec_im]/observationMedia/value</b>		
Result Group Specimen Detail (SPECIMEN) > <b>COLLECTION AND HANDLING</b>	Collection and handling requirements.	0..1	n/a		This logical NEHTA data component has no mapping to CDA.  The cardinality of this component propagates to its children.

NEHTA SCS Data Component	Data Component Definition	Card	CDA Schema Data Element	Vocab	Comments
Result Group Specimen Detail (SPECIMEN) > COLLECTION AND HANDLING > <b>Sampling Preconditions</b>	Any conditions to be met before the sample should be taken.	0..1	component[gp_specimen]/observation/entryRelationship[smp_pre]/@typeCode="COMP"		
			component[gp_specimen]/observation/entryRelationship[smp_pre]/observation		
			component[gp_specimen]/observation/entryRelationship[smp_pre]/observation/@classCode="OBS"		
			component[gp_specimen]/observation/entryRelationship[smp_pre]/observation/@moodCode="EVN"		
			component[gp_specimen]/observation/entryRelationship[smp_pre]/observation/code		
			component[gp_specimen]/observation/entryRelationship[smp_pre]/observation/code/@code="103.16171"		
			component[gp_specimen]/observation/entryRelationship[smp_pre]/observation/code/@codeSystem="1.2.36.1.2001.1001.101"		
			component[gp_specimen]/observation/entryRelationship[smp_pre]/observation/code/@codeSystemName	The value <b>SHOULD</b> be "NCTIS Data Components".  See <a href="#">CodeSystem OIDs</a> .	Optional CDA element.
			component[gp_specimen]/observation/entryRelationship[smp_pre]/observation/code/@displayName="Sampling Preconditions"		
component[gp_specimen]/observation/entryRelationship[smp_pre]/observation/value:CD	NS	See <code> for available attributes.			
Result Group Specimen Detail (SPECIMEN) > <b>HANDLING AND PROCESSING</b>	Workflow of specimen processing or handling.	1..1	N/A		This logical NEHTA data component has no mapping to CDA.  The cardinality of this component propagates to its children.
Result Group Specimen Detail (SPECIMEN) > HANDLING AND PROCESSING > <b>Date and Time of Collection (Collection DateTime)</b>	Date, and optionally time, of collection.	1..1	component[gp_specimen]/observation/effectiveTime		See <time> for available attributes.

NEHTA SCS Data Component	Data Component Definition	Card	CDA Schema Data Element	Vocab	Comments
Result Group Specimen Detail (SPECIMEN) > HANDLING AND PROCESSING > <b>Collection Setting</b>	Identification of the setting at which the specimen was collected from a subject of care.	0..1	component[gp_specimen]/observation/entryRelationship[coll_set]/@typeCode="COMP"		
			component[gp_specimen]/observation/entryRelationship[coll_set]/observation		
			component[gp_specimen]/observation/entryRelationship[coll_set]/observation/@classCode="OBS"		
			component[gp_specimen]/observation/entryRelationship[coll_set]/observation/@moodCode="EVN"		
			component[gp_specimen]/observation/entryRelationship[coll_set]/observation/code		
			component[gp_specimen]/observation/entryRelationship[coll_set]/observation/code/@code="103.16529"		
			component[gp_specimen]/observation/entryRelationship[coll_set]/observation/code/@codeSystem="1.2.36.1.2001.1001.101"		
			component[gp_specimen]/observation/entryRelationship[coll_set]/observation/code/@codeSystemName	The value <b>SHOULD</b> be "NCTIS Data Components".  See <a href="#">CodeSystem OIDs</a> .	Optional CDA element.
			component[gp_specimen]/observation/entryRelationship[coll_set]/observation/code/@displayName="Collection Setting"		
			component[gp_specimen]/observation/entryRelationship[coll_set]/observation/value:ST		
Result Group Specimen Detail (SPECIMEN) > HANDLING AND PROCESSING > <b>Date and Time of Receipt (DateTime Received)</b>	The date and time that the sample was received at the laboratory.	0..1	component[gp_specimen]/observation/entryRelationship[date_rec]/@typeCode="COMP"		
			component[gp_specimen]/observation/entryRelationship[date_rec]/observation		
			component[gp_specimen]/observation/entryRelationship[date_rec]/observation/@classCode="OBS"		
			component[gp_specimen]/observation/entryRelationship[date_rec]/observation/@moodCode="EVN"		
			component[gp_specimen]/observation/entryRelationship[date_rec]/observation/code		
			component[gp_specimen]/observation/entryRelationship[date_rec]/observation/code/@code="103.11014"		
			component[gp_specimen]/observation/entryRelationship[date_rec]/observation/code/@codeSystem="1.2.36.1.2001.1001.101"		
			component[gp_specimen]/observation/entryRelationship[date_rec]/observation/code/@codeSystemName	The value <b>SHOULD</b> be "NCTIS Data Components".  See <a href="#">CodeSystem OIDs</a> .	Optional CDA element.
			component[gp_specimen]/observation/entryRelationship[date_rec]/observation/code/@displayName="DateTime Received"		
			component[gp_specimen]/observation/entryRelationship[date_rec]/observation/value:TS		See <time> for available attributes.

NEHTA SCS Data Component	Data Component Definition	Card	CDA Schema Data Element	Vocab	Comments
Result Group Specimen Detail (SPECIMEN) > IDENTIFIERS	Sample identifications.	0..1	N/A		This logical NEHTA data component has no mapping to CDA.  The cardinality of this component propagates to its children.
Result Group Specimen Detail (SPECIMEN) > IDENTIFIERS > Specimen Identifier	Unique identifier of the specimen, normally assigned by the laboratory.	0..1	component[gp_specimen]/observation/specimen/specimenRole/id		See <id> for available attributes.
Result Group Specimen Detail (SPECIMEN) > IDENTIFIERS > Parent Specimen Identifier	Unique identifier of the parent specimen where the specimen is split into sub-samples.	0..1	component[gp_specimen]/observation/entryRelationship[prnt_id]/@typeCode="COMP"		
			component[gp_specimen]/observation/entryRelationship[prnt_id]/observation		
			component[gp_specimen]/observation/entryRelationship[prnt_id]/observation/@classCode="OBS"		
			component[gp_specimen]/observation/entryRelationship[prnt_id]/observation/@moodCode="EVN"		
			component[gp_specimen]/observation/entryRelationship[prnt_id]/observation/code		
			component[gp_specimen]/observation/entryRelationship[prnt_id]/observation/code/@code="103.16187"		
			component[gp_specimen]/observation/entryRelationship[prnt_id]/observation/code/@codeSystem="1.2.36.1.2001.1001.101"		
			component[gp_specimen]/observation/entryRelationship[prnt_id]/observation/code/@codeSystemName	The value <b>SHOULD</b> be "NCTIS Data Components".  See <a href="#">CodeSystem OIDs</a> .	Optional CDA element.
			component[gp_specimen]/observation/entryRelationship[prnt_id]/observation/code/@displayName="Parent Specimen Identifier"		
component[gp_specimen]/observation/entryRelationship[prnt_id]/observation/specimen/specimenRole/id			See <id> for available attributes.		
Result Group Specimen Detail (SPECIMEN) > IDENTIFIERS > Container Identifier	Unique identifier given to the container in which the specimen is transported or processed.	0..1	component[gp_specimen]/observation/specimen/specimenRole/specimenPlayingEntity/ext:asSpecimenInContainer		See NEHTA CDA extension: <a href="#">Container</a>
			component[gp_specimen]/observation/specimen/specimenRole/specimenPlayingEntity/ext:asSpecimenInContainer/@classCode="CONT"		
			component[gp_specimen]/observation/specimen/specimenRole/specimenPlayingEntity/ext:asSpecimenInContainer/ext:container		
			component[gp_specimen]/observation/specimen/specimenRole/specimenPlayingEntity/ext:asSpecimenInContainer/ext:container/ext:id		See <id> for available attributes.

## Example 7.7. Result Group Specimen Detail (SPECIMEN) XML Fragment

<!-- This xml fragment is provided to demonstrate an example instance of each structured element in the CDA Mapping table. It is illustrative only. Logical model constraints on allowed combinations of child components are ignored in order to provide coverage of structured elements. This fragment cannot be treated as clinically valid. While the values in the fragment are conformant with the CDA Mapping table they are typically exaggerated to highlight the semantic meaning of the structured elements and may not be indicative of the expected values in a clinical document. While every effort has been taken to ensure that the examples are consistent with the message specification, where there are conflicts with the written message specification or schema, the specification or schema will take precedence. -->

```
<ClinicalDocument xmlns="urn:h17-org:v3"
  xmlns:ext="http://ns.electronichealth.net.au/Ci/Cda/Extensions/3.0"
  ...
  <!-- Begin CDA Header -->
  ...
  <!-- End CDA Header -->
  <!-- Begin CDA Body -->
  <component>
    <structuredBody>
      ...
      <!-- Begin PATHOLOGY -->
      <component typeCode="COMP">
        <section classCode="DOCSECT" moodCode="EVN">
          ...
          <!-- Begin PATHOLOGY TEST RESULT -->
          <component>
            <section classCode="DOCSECT" moodCode="EVN">
              ...
              <entry>
                <observation classCode="OBS" moodCode="EVN">
                  ...
                  <!-- Begin Result Group (PATHOLOGY TEST RESULT GROUP) -->
                  <entryRelationship typeCode="COMP">
                    <organizer classCode="BATTERY" moodCode="EVN">
                      ...
                      <!-- Begin Result (INDIVIDUAL PATHOLOGY TEST RESULT) -->
                      <component>
                        <observation classCode="OBS" moodCode="EVN">
                          ...
                        </observation>
                      </component>
                    <!-- Begin Result (INDIVIDUAL PATHOLOGY TEST RESULT) -->
                    <!-- Begin Result Group Specimen Detail (SPECIMEN) -->
                    <component>
                      <observation classCode="OBS" moodCode="EVN">
                        <!-- ID is used for system purposes such as matching -->
                        <id root="CCCD55C-EFD0-11DF-BEA2-A6CCDF72085" />
                        <code code="102.16156.220.2.2" codeSystem="1.2.36.1.2001.1001.101" codeSystemName="NCTIS Data Components" displayName="Specimen" />
                        <!-- Date and Time of Collection (Collection DateTime) -->
                        <effectiveTime value="201310201235+1000" />
                      </observation>
                    </component>
                  </entryRelationship>
                </entry>
              </section>
            </component>
          </section>
        </component>
      </structuredBody>
    </component>
  </CDA Body -->
  ...
  <!-- End CDA Header -->
  ...
  <!-- End CDA Header -->
```

```

<!-- Collection Procedure -->
<methodCode code="48635004" codeSystem="2.16.840.1.113883.6.96" codeSystemName="SNOMED CT"
  displayName="Fine needle biopsy" />

<!-- Anatomical Site (ANATOMICAL LOCATION) :: Examples provided of all three allowed variants. These variants are mutually exclusive -->
<!-- Begin Example with complete SPECIFIC LOCATION -->
<!-- Begin SPECIFIC LOCATION -->
<!-- Name of Location (Anatomical Location Name) -->
<targetSiteCode code="51185008" codeSystem="2.16.840.1.113883.6.96" codeSystemName="SNOMED CT" displayName="thorax">

  <!-- Begin Side -->
  <qualifier>
    <name code="272741003" codeSystem="2.16.840.1.113883.6.96" codeSystemName="SNOMED CT" displayName="Laterality" />
    <value code="7771000" codeSystem="2.16.840.1.113883.6.96" codeSystemName="SNOMED CT" displayName="left" xsi:type="CD" />
  </qualifier>
  <!-- End Side -->

</targetSiteCode>
<!-- End SPECIFIC LOCATION -->
<!-- End Example with complete SPECIFIC LOCATION -->

<!-- Begin Example with partial SPECIFIC LOCATION -->
<!-- Begin SPECIFIC LOCATION -->
<!-- Name of Location (Anatomical Location Name) -->
<targetSiteCode code="51185008" codeSystem="2.16.840.1.113883.6.96" codeSystemName="SNOMED CT" displayName="thorax" />
<!-- End SPECIFIC LOCATION -->
<!-- End Example with partial SPECIFIC LOCATION -->

<!-- Begin Example with Description -->
<targetSiteCode>
  <!-- Description (Anatomical Location Description) -->
  <originalText>Chest/Thorax</originalText>
</targetSiteCode>
<!-- End SPECIFIC LOCATION -->
<!-- End Example with Description -->
<!-- End Anatomical Site (ANATOMICAL LOCATION) -->

<!-- Begin Physical Details -->
<specimen>
  <specimenRole>
    <!-- Specimen Identifier -->
    <id root="1538103e-845b-4f86-95ed-33b62e7589d0" />

    <!-- Begin Physical Details (PHYSICAL PROPERTIES OF AN OBJECT) -->
    <specimenPlayingEntity>
      <!-- Specimen Tissue Type -->
      <code code="258442002" codeSystem="2.16.840.1.113883.6.96" codeSystemName="SNOMED CT" displayName="Fluid sample" />

      <!-- Begin Weight/Volume -->
      <quantity unit="mL" value="5" />
      <!-- End Weight/Volume -->

      <!-- Begin Description (Object Description) -->
      <desc xsi:type="ST">5 mL</desc>
      <!-- End Description (Object Description) -->

      <!-- Begin Container Identifier -->
      <ext:asSpecimenInContainer classCode="CONT">
        <ext:container>
          <ext:id extension="CNH45218964" root="CA54FD22-76B8-11E0-AC87-0EE34824019B" />
        </ext:container>
      </ext:asSpecimenInContainer>
      <!-- End Container Identifier -->
    
```

```
</specimenPlayingEntity>
<!-- End Physical Details (PHYSICAL PROPERTIES OF AN OBJECT) -->
</specimenRole>
</specimen>
<!-- End Physical Details -->

<!-- Begin Anatomical Location Image -->
<entryRelationship typeCode="SPRT">
<observationMedia classCode="OBS" moodCode="EVN">
<id root="3953A078-0365-11E1-B90D-41D04724019B" />
<value mediaType="image/jpeg" >
<reference value="location.jpeg" />
</value>
</observationMedia>
</entryRelationship>
<!-- End Anatomical Location Image -->

<!-- Begin Image -->
<entryRelationship typeCode="SPRT">
<observationMedia classCode="OBS" moodCode="EVN">
<id root="1d64bb51-c5b3-4048-9a9f-e753f4e3c203" />
<value mediaType="image/jpeg" >
<reference value="specimen.jpeg" />
</value>
</observationMedia>
</entryRelationship>
<!-- End Image -->

<!-- Begin Sampling Preconditions -->
<entryRelationship typeCode="COMP">
<observation classCode="OBS" moodCode="EVN">
<code code="103.16171" codeSystem="1.2.36.1.2001.1001.101"
codeSystemName="NCTIS Data Components" displayName="Sampling Preconditions" />
<value code="16985007" codeSystem="2.16.840.1.113883.6.96" codeSystemName="SNOMED CT"
displayName="Fasting" xsi:type="CD" />
</observation>
</entryRelationship>
<!-- End Sampling Preconditions -->

<!-- Begin Collection Setting -->
<entryRelationship typeCode="COMP">
<observation classCode="OBS" moodCode="EVN">
<code code="103.16529" codeSystem="1.2.36.1.2001.1001.101"
codeSystemName="NCTIS Data Components" displayName="Collection Setting" />
<value xsi:type="ST">Pathology Clinic</value>
</observation>
</entryRelationship>
<!-- End Collection Setting -->

<!-- Begin Date and Time of Receipt (DateTime Received) -->
<entryRelationship typeCode="COMP">
<observation classCode="OBS" moodCode="EVN">
<code code="103.11014" codeSystem="1.2.36.1.2001.1001.101"
codeSystemName="NCTIS Data Components" displayName="DateTime Received" />
<value value="201112141120+1000" xsi:type="TS" />
</observation>
</entryRelationship>
<!-- End Date and Time of Receipt (DateTime Received) -->

<!-- Begin Parent Specimen Identifier -->
<entryRelationship typeCode="COMP">
<observation classCode="OBS" moodCode="EVN">
```



```
<code code="103.16187" codeSystem="1.2.36.1.2001.1001.101"
codeSystemName="NCTIS Data Components" displayName="Parent Specimen Identifier" />
<specimen>
  <specimenRole>
    <id root="7013b12a-f9d0-4197-9726-88a6803d4d13" />
  </specimenRole>
</specimen>
</observation>
</entryRelationship>
<!-- End Parent Specimen Identifier -->

</observation>
</component>
<!-- End Result Group Specimen Detail (SPECIMEN) -->

</organizer>
</entryRelationship>
<!-- End Result Group (PATHOLOGY TEST RESULT GROUP) -->

...

</observation>
</entry>
</section>
</component>
<!-- End PATHOLOGY TEST RESULT -->
...

</section>
</component>
<!-- End PATHOLOGY -->
...

</structuredBody>
</component>
<!-- End CDA Body -->
</ClinicalDocument>
```

### 7.1.1.1.3 REPORTING PATHOLOGIST

#### Identification

<b>Name</b>	REPORTING PATHOLOGIST
<b>Metadata Type</b>	Data Group
<b>Identifier</b>	DG-10296

#### Relationships

##### Parent

Data Type	Name	Occurrences (child within parent)
	PATHOLOGY TEST RESULT	0..1

## CDA R-MIM Representation

Figure 7.8 REPORTING PATHOLOGIST shows a subset of the CDA R-MIM containing those classes being referred to in the CDA Mapping. This data component maps to CDA Body elements.

The REPORTING PATHOLOGIST data group instantiated as PERSON is represented by the participant participation of the ClinicalStatement. The participant is a person in the role of playingEntity (PlayingEntity class). The entity identifier of the participant is mapped to the EntityIdentifier class (NEHTA CDA extension).

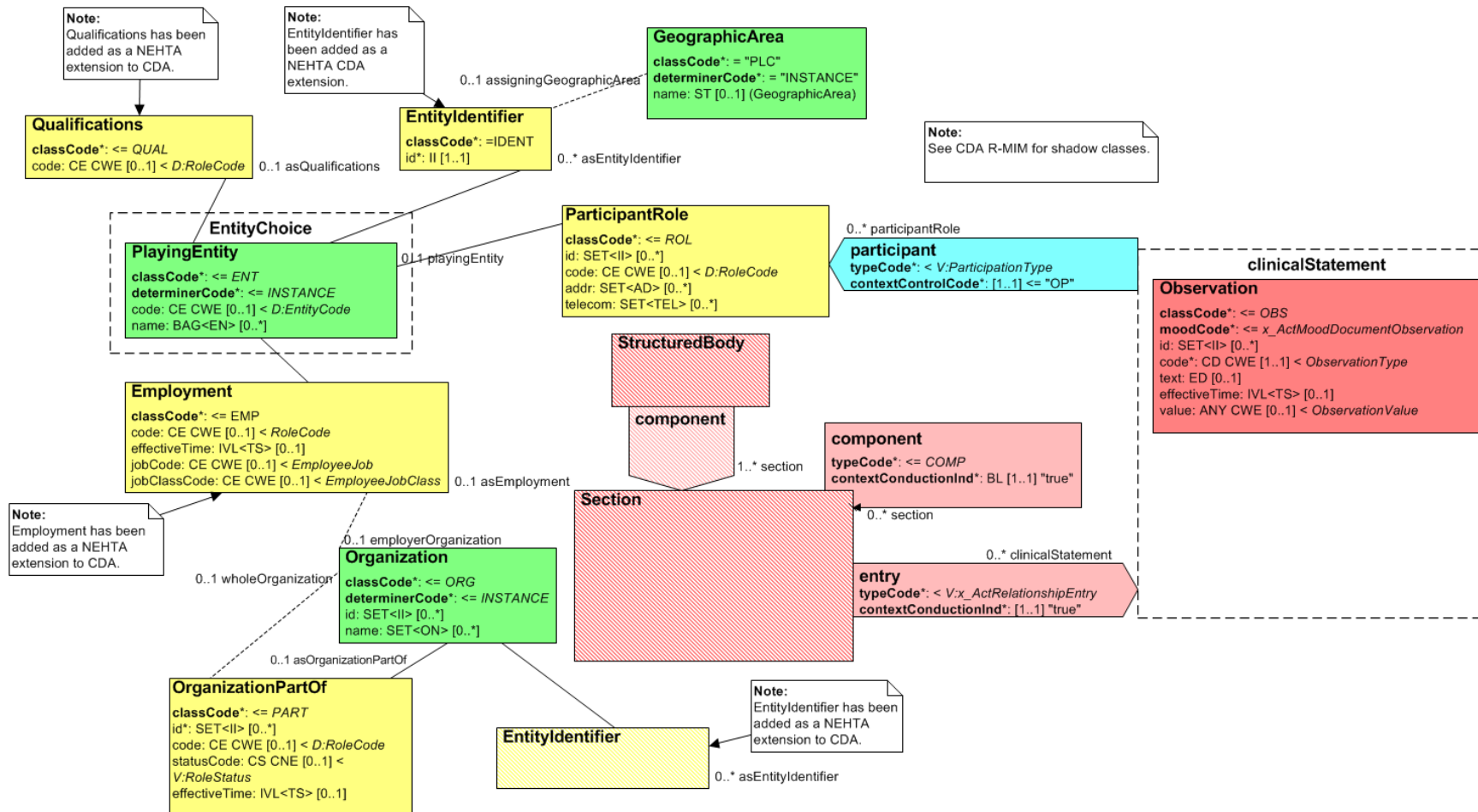

Figure 7.8. REPORTING PATHOLOGIST

Figure 7.9 REPORTING PATHOLOGIST - Entitlement shows a subset of the CDA R-MIM containing those classes being referred to in the CDA Mapping. This data component maps to CDA Body elements.

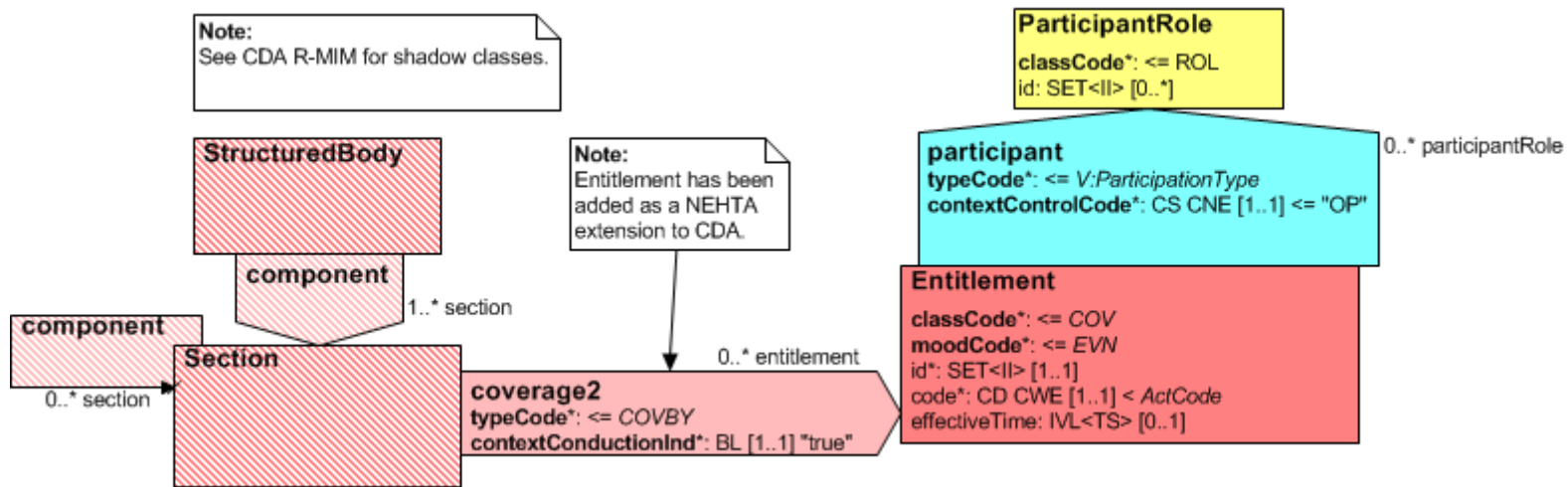

Figure 7.9. REPORTING PATHOLOGIST - Entitlement

**CDA Mapping**

NEHTA SCS Data Component	Data Component Definition	Card	CDA Schema Data Element	Vocab	Comments
<b>CDA Body Level 3 Data Elements</b>			Context: ClinicalDocument/component/structuredBody/component[pathology]/section/component[path_test]/section/entry[path_test_res]/observation/		
<b>REPORTING PATHOLOGIST</b>	Pathologist who is responsible for the pathology test result.	1..1	<b>participant</b>		A Pathology Report <b>SHALL</b> contain one instance of REPORTING PATHOLOGIST in the CONTEXT (section/author), or contain one instance of REPORTING PATHOLOGIST in each instance of Pathology Test Result (section/component/section/participant), but not both.
<b>REPORTING PATHOLOGIST &gt; Participation Period</b>	The time interval during which the participation in the health care event occurred.	1..1	participant/ <b>time</b>	Although the definition of this element states that it is a time interval, the following applies: "The end of the participation period of a [participant] participation is the time associated with the completion of editing the content..." Thus only the end time need be recorded.	Required CDA element. The author/time element <b>SHALL</b> be implemented as either: <ul style="list-style-type: none"> <li>• a value attribute (populated with the end time of the authorship or encounter, as appropriate); or</li> <li>• a high element AND a low element, both with value attributes and neither with a nullFlavor attribute.</li> </ul>
<b>REPORTING PATHOLOGIST &gt; Participation Type</b>	The categorisation of the nature of the participant's involvement in the healthcare event described by this participation.	1..1	participant/ <b>@typeCode="RESP"</b>		participant/ @typeCode="RESP" and participant/code satisfy the logical model constraint: Participation Type <b>SHALL</b> have an implementation-specific value equivalent to "Reporting Pathologist".

NEHTA SCS Data Component	Data Component Definition	Card	CDA Schema Data Element	Vocab	Comments
n/a	n/a	1..1	participant/participantRole participant/participantRole/@classCode="ASSIGNED" participant/participantRole/id	UUID  This is a technical identifier that is used for system purposes such as matching. If a suitable internal key is not available, a UUID <b>MAY</b> be used.	Required CDA element.
REPORTING PATHOLOGIST > <b>Role</b>	The involvement or role of the participant in the related action from a healthcare perspective rather than the specific participation perspective.	1..1	participant/participantRole/code	Role <b>SHOULD</b> have a value chosen from <a href="#">1220.0 - ANZSCO - Australian and New Zealand Standard Classification of Occupations, First Edition, Revision 1 [ABS2009]</a> .  However, if a suitable value in this set cannot be found, then any code set that is both registered with HL7 and publicly available <b>MAY</b> be used.	
REPORTING PATHOLOGIST > <b>Participant</b>	Details pertinent to the identification of an individual or organisation or device that has participated in a healthcare event/encounter/clinical interaction.	1..1	participant/participantRole/playingEntity		
REPORTING PATHOLOGIST > Participant > <b>Entity Identifier</b>	A number or code issued for the purpose of identifying a participant within a healthcare context.	1..*	participant/participantRole/playingEntity/<Entity Identifier>	The value of one Entity Identifier <b>SHALL</b> be an Australian HPI-I.	See common pattern: <a href="#">Entity Identifier</a> .
REPORTING PATHOLOGIST > Participant > <b>Address</b>	The description of a location where an entity is located or can be otherwise reached or found and a description of the purpose for which that address is primarily used by that entity.	1..*	participant/participantRole/<Address>	AUSTRALIAN OR INTERNATIONAL ADDRESS <b>SHALL</b> be instantiated as an AUSTRALIAN ADDRESS.  Address Purpose (addr/@use) <b>SHALL</b> be set to Business (see <a href="#">AS 5017-2006: Health Care Client Identifier Address Purpose</a> ).	See common pattern: <a href="#">Address</a> .

NEHTA SCS Data Component	Data Component Definition	Card	CDA Schema Data Element	Vocab	Comments
REPORTING PATHOLOGIST > Participant > <b>Electronic Communication Detail</b>	The electronic communication details of entities.	1..*	participant/participantRole/< <b>Electronic Communication Detail</b> >	Electronic Communication Usage Code (telecom/@use) <b>SHALL</b> be set to Workplace (see HL7: TelecommunicationAddressUse).	See common pattern: <a href="#">Electronic Communication Detail</a> .
REPORTING PATHOLOGIST > Participant > <b>Person or Organisation or Device</b>	Represents a choice to be made at run-time between PERSON, ORGANISATION or DEVICE.	1..1	n/a	PERSON OR ORGANISATION OR DEVICE <b>SHALL</b> be instantiated as a PERSON.	This logical NEHTA data component has no mapping to CDA.  The cardinality of this component propagates to its children.
REPORTING PATHOLOGIST > Participant > Person or Organisation or Device > <b>Person</b>	An individual who is in the role of healthcare provider, who uses or is a potential user of a healthcare service, or is in some way related to, or a representative of, a subject of care (patient).	1..1	participant/participantRole/playingEntity/@classCode="PSN"		
REPORTING PATHOLOGIST > Participant > Person or Organisation or Device > Person > <b>Person Name</b>	The appellation by which an individual may be identified separately from any other within a social context.	1..*	participant/participantRole/playingEntity/< <b>Person Name</b> >	Where the name of the REPORTING PATHOLOGIST is known but is not to be disclosed nullFlavor="MSK" is permitted.	See common pattern: <a href="#">Person Name</a> .
REPORTING PATHOLOGIST > Participant > Person or Organisation or Device > Person > <b>Employment Detail</b>	A person's occupation and employer.	1..1	participant/participantRole/playingEntity/< <b>Employment</b> >		See common pattern: <a href="#">Employment</a> .
<b>CDA Body Level 3 Data Elements</b>			ClinicalDocument/component/structuredBody/component[pathology]/section/component[path_test]/section/		
REPORTING PATHOLOGIST > Participant > <b>Entitlement</b>	The entitlement or right of a participant to act in a given capacity (as defined by Entitlement Type) within a healthcare context.	0..*	<b>ext:coverage2/@typeCode="COVBY"</b>		
			ext:coverage2/ext:entitlement		
			ext:coverage2/ext:entitlement/@classCode="COV"		
			ext:coverage2/ext:entitlement/@moodCode="EVN"		
			ext:coverage2/ext:entitlement/ext:participant/@typeCode="HLD"		
			ext:coverage2/ext:entitlement/ext:participant/ext:participantRole/@classCode="ASSIGNED"		
			ext:coverage2/ext:entitlement/ext:participant/ext:participantRole/ext:id	UUID  This is a technical identifier that is used for system purposes such as matching. If a suitable internal key is not available, a UUID <b>MAY</b> be used.	This <b>SHALL</b> hold the same value as participant/participantRole/id.



NEHTA SCS Data Component	Data Component Definition	Card	CDA Schema Data Element	Vocab	Comments
REPORTING PATHOLOGIST > Participant > Entitlement > <b>Entitlement Number</b>	A number or code issued for the purpose of identifying the entitlement or right of a participant to act in a given capacity (as defined by Entitlement Type) within a healthcare context.	1..1	ext:coverage2/ext:entitlement/ <b>ext:id</b>		See <id> for available attributes.
REPORTING PATHOLOGIST > Participant > Entitlement > <b>Entitlement Type</b>	The description of the scope of an entitlement.	1..1	ext:coverage2/ext:entitlement/ <b>ext:code</b>	<a href="#">NCTIS: Admin Codes - Entitlement Type</a>	
REPORTING PATHOLOGIST > Participant > Entitlement > <b>Entitlement Validity Duration</b>	The time interval for which an entitlement is valid.	0..1	ext:coverage2/ext:entitlement/ <b>ext:effectiveTime</b>		See <time> for available attributes.
<b>CDA Body Level 3 Data Elements</b>			Context: ClinicalDocument/component/structuredBody/component[pathology]/section/component[path_test]/section/entry[path_test_res]/observation/		
REPORTING PATHOLOGIST > Participant > <b>Qualifications</b>	A list of professional certifications, and certificates recognizing having passed a course.	0..1	participant/participantRole/playingEntity/ <b>ext:asQualifiedEntity</b>		See NEHTA CDA extension: <a href="#">Qualifications</a> .
			participant/participantRole/playingEntity/ext:asQualifiedEntity/ <b>@classCode="QUAL"</b>		
			participant/participantRole/playingEntity/ext:asQualifiedEntity/ <b>ext:code/originalText</b>	Qualifications is a text field, so the text list is entered in the originalText field of the code element.	

## Example 7.8. REPORTING PATHOLOGIST XML Fragment

<!-- This xml fragment is provided to demonstrate an example instance of each structured element in the CDA Mapping table. It is illustrative only. Logical model constraints on allowed combinations of child components are ignored in order to provide coverage of structured elements. This fragment cannot be treated as clinically valid. While the values in the fragment are conformant with the CDA Mapping table they are typically exaggerated to highlight the semantic meaning of the structured elements and may not be indicative of the expected values in a clinical document. While every effort has been taken to ensure that the examples are consistent with the message specification, where there are conflicts with the written message specification or schema, the specification or schema will take precedence. -->

```
<ClinicalDocument xmlns="urn:h17-org:v3"
  xmlns:ext="http://ns.electronichealth.net.au/Ci/Cda/Extensions/3.0"
  ...
  >
  <!-- Begin CDA Header -->
  ...
  <!-- End CDA Header -->
  <!-- Begin CDA Body -->
  <component>
    <structuredBody>
      ...
      <!-- Begin PATHOLOGY -->
      <component>
        <section>
          ...
          <!-- Begin PATHOLOGY TEST RESULT -->
          <component>
            <section classCode="DOCSECT" moodCode="EVN">
              ...
              <!-- Begin Narrative text -->
              <text>
                <table>
                  <tbody>
                    <tr>
                      <th>Australian Medicare Prescriber Number</th>
                      <td>049960CT</td>
                    </tr>
                  </tbody>
                </table>
              </text>
              <!-- End Narrative text -->
              <!-- Begin Reporting Pathologist Entitlement -->
              <ext:coverage2 typeCode="COVBY">
                <ext:entitlement classCode="COV" moodCode="EVN">
                  <ext:id assigningAuthorityName="Medicare Prescriber number"
                    root="1.2.36.174030967.0.3"
                    extension="049960CT" />
                  <ext:code code="10" codeSystem="1.2.36.1.2001.1001.101.104.16047"
                    codeSystemName="NCTIS Entitlement Type Values"
                    displayName="Medicare Prescriber Number"/>
                  <ext:effectiveTime>
                    <low value="20050101"/>
                    <high value="20250101"/>
                  </ext:effectiveTime>
                  <ext:participant typeCode="HLD">
                    <ext:participantRole classCode="ASSIGNED">
```

```

        <!-- Same as the prescriber (assignedAuthor) id -->
        <ext:id root="33b9526c-2084-4371-8577-d9a5d84300b5"/>
    </ext:participantRole>
</ext:participant>
</ext:entitlement>
</ext:coverage2>
<!-- End Reporting Pathologist Entitlement -->
...
<entry>
    <observation classCode="OBS" moodCode="EVN">
        <!-- Begin REPORTING PATHOLOGIST -->
        <participant typeCode="RESP">
            <!-- DateTime Authored -->
            <time value="201110201235+1000" />

            <participantRole classCode="ASSIGNED">
                <!-- ID is used for system purposes such as matching -->
                <id root="33b9526c-2084-4371-8577-d9a5d84300b5" />

                <!-- Role -->
                <code code="253915" codeSystem="2.16.840.1.113883.13.62"
                    codeSystemName="1220.0 - ANZSCO - Australian and New Zealand
                    Standard Classification of Occupations, First Edition, Revision 1"
                    displayName="Pathologist"/>

                <!-- Address -->
                <addr use="WP">
                    <streetAddressLine>8 Pathology Street</streetAddressLine>
                    <city>Nehrtaville</city>
                    <state>QLD</state>
                    <postalCode>5555</postalCode>
                    <additionalLocator>32568931</additionalLocator>
                </addr>

                <!-- Electronic Communication Detail -->
                <telecom use="WP" value="tel:0712341234" />

                <!-- Participant -->
                <playingEntity classCode="PSN">
                    <!-- Person Name -->
                    <name nullFlavor="MSK" />

                    <!-- Entity Identifier -->
                    <ext:asEntityIdentifier classCode="IDENT">
                        <ext:id assigningAuthorityName="HPI-I" root="1.2.36.1.2001.1003.0.8003619900015717"/>
                        <ext:assigningGeographicArea classCode="PLC">
                            <ext:name>National Identifier</ext:name>
                        </ext:assigningGeographicArea>
                    </ext:asEntityIdentifier>

                    <!-- Employment Details -->
                    <ext:asEmployment classCode="EMP">
                        <!-- Position In Organisation -->
                        <ext:code>
                            <originalText>Pathologist</originalText>
                        </ext:code>

                        <!-- Occupation -->
                        <ext:jobCode code="253915" codeSystem="2.16.840.1.113883.13.62"
                            codeSystemName="1220.0 - ANZSCO - Australian and New Zealand

```

```
Standard Classification of Occupations, First Edition, Revision 1"
  displayName="Pathologist" />

<!-- Employment Type -->
<ext:jobClassCode code="FT" codeSystem="2.16.840.1.113883.5.1059"
  codeSystemName="HL7:EmployeeJobClass"
  displayName="full-time" />

<!-- Employer Organisation -->
<ext:employerOrganization>
  <!-- Department/Unit -->
  <name>Acme Hospital One</name>
  <asOrganizationPartOf>
    <wholeOrganization>
      <!-- Organisation Name -->
      <name use="ORGB">Acme Hospital Group</name>

      <!-- Entity Identifier (HPI-0) -->
      <ext:asEntityIdentifier classCode="IDENT">
        <ext:id assigningAuthorityName="HPI-0" root="1.2.36.1.2001.1003.0.8003621566684455" />
        <ext:assigningGeographicArea classCode="PLC">
          <ext:name>National Identifier</ext:name>
        </ext:assigningGeographicArea>
      </ext:asEntityIdentifier>

    </wholeOrganization>
  </asOrganizationPartOf>
</ext:employerOrganization>
</ext:asEmployment>

<ext:asQualifiedEntity classCode="QUAL">
  <ext:code>
    <originalText>M.B.B.S</originalText>
  </ext:code>
</ext:asQualifiedEntity>

</playingEntity>
</participantRole>
</participant>
<!-- End REPORTING PATHOLOGIST -->

</observation>
</entry>
</section>
</component>
<!-- End PATHOLOGY TEST RESULT -->
...
</section>
</component>
<!-- End PATHOLOGY -->

</structuredBody>
</component>
<!-- End CDA Body -->

</ClinicalDocument>
```

## 7.1.1.2 REPORTING PATHOLOGIST

### Identification

Name	REPORTING PATHOLOGIST
Metadata Type	Data Group
Identifier	DG-10296

### Relationships

#### Parent

Data Type	Name	Occurrences (child within parent)
	PATHOLOGY	1..1

## CDA R-MIM Representation

Figure 7.10 REPORTING PATHOLOGIST shows a subset of the CDA R-MIM containing those classes being referred to in the CDA Mapping. This data component maps to CDA Body elements.

The REPORTING PATHOLOGIST data group instantiated as PERSON is represented by the author participation of the AssignedAuthor Person relationship. The entity identifier of the participant is mapped to the EntityIdentifier class (NEHTA CDA extension).

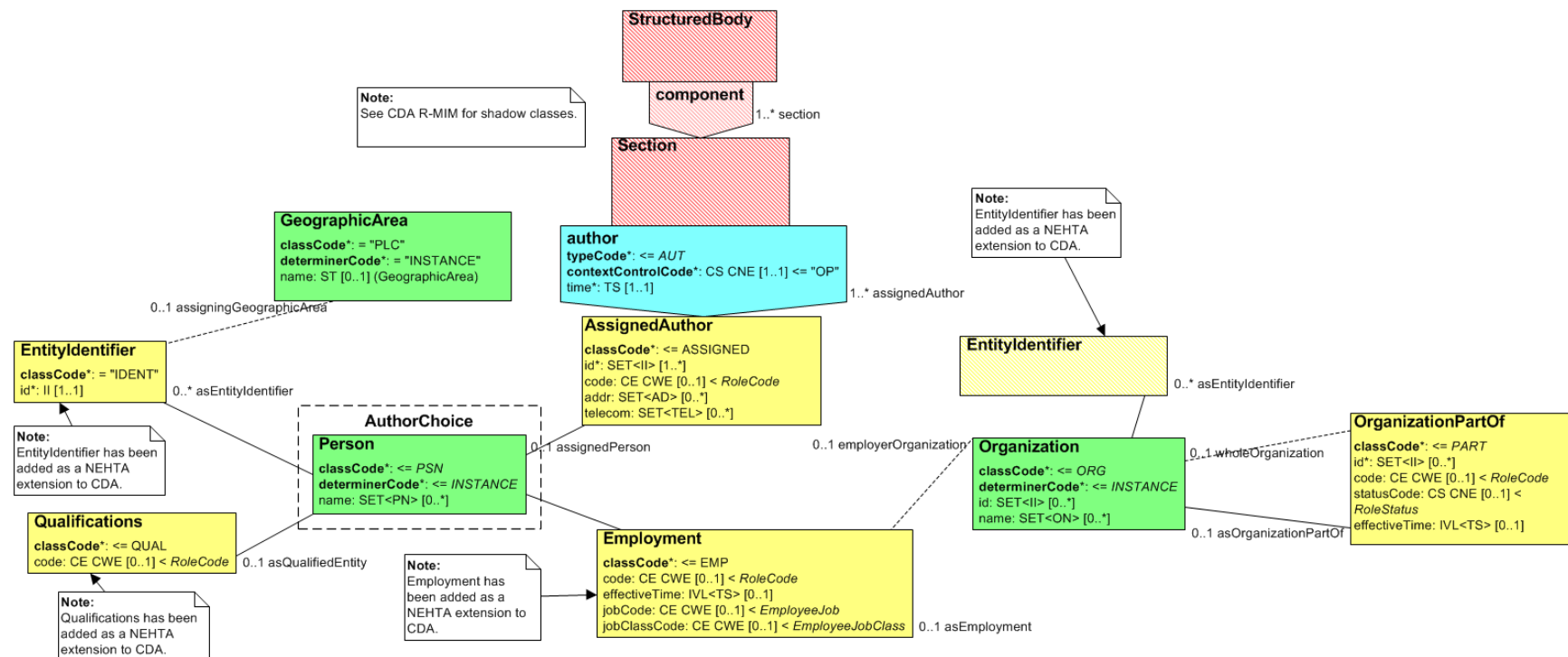

Figure 7.10. REPORTING PATHOLOGIST

Figure 7.11 REPORTING PATHOLOGIST - Entitlement shows a subset of the CDA R-MIM containing those classes being referred to in the CDA Mapping. This data component maps to CDA Body elements.

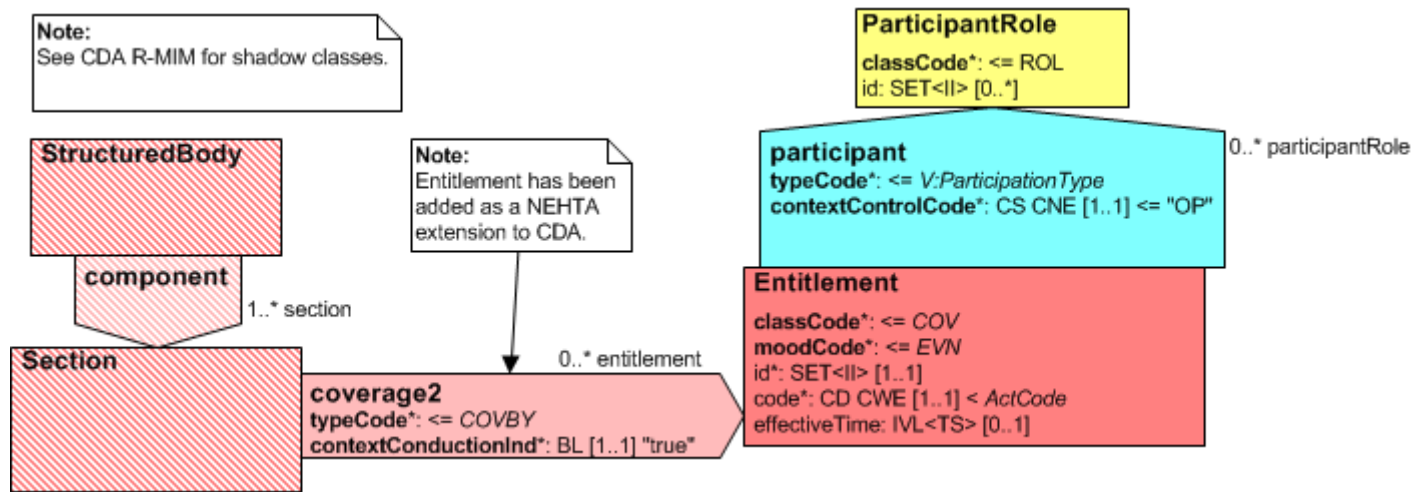

Figure 7.11. REPORTING PATHOLOGIST - Entitlement

## CDA Mapping

NEHTA SCS Data Component	Data Component Definition	Card	CDA Schema Data Element	Vocab	Comments
<b>CDA Body Level 2 Data Elements</b>					
Context: ClinicalDocument/component/structuredBody/component[pathology]/section/					
REPORTING PATHOLOGIST	Pathologist who is responsible for the pathology test result.	1..1	author		<p>This logical data component could not be mapped to CDA Header elements and is instead mapped as a child of <a href="#">PATHOLOGY</a>.</p> <p>A Pathology Report <b>SHALL</b> contain one instance of REPORTING PATHOLOGIST in the CONTEXT (section/author), or contain one instance of REPORTING PATHOLOGIST in each instance of Pathology Test Result (section/component/section/participant), but not both.</p>
REPORTING PATHOLOGIST > Participation Period	The time interval during which the participation in the health care event occurred.	1..1	author/time	Although the definition of this element states that it is a time interval, the following applies: "The end of the participation period of a [Author] participation is the time associated with the completion of editing the content..." Thus only the end time need be recorded.	<p>Required CDA element.</p> <p>The author/time element <b>SHALL</b> be implemented as either:</p> <ul style="list-style-type: none"> <li>a value attribute (populated with the end time of the authorship or encounter, as appropriate); or</li> <li>a high element AND a low element, both with value attributes and neither with a nullFlavor attribute.</li> </ul>
REPORTING PATHOLOGIST > Participation Type	The categorisation of the nature of the participant's involvement in the healthcare event described by this participation.	1..1	n/a	Participation Type <b>SHALL</b> have an implementation-specific value equivalent to "Reporting Pathologist".	Not mapped directly; encompassed implicitly in author/@typeCode="AUT" (optional, fixed value).
n/a	n/a	1..1	author/assignedAuthor/id	<p>UUID</p> <p>This is a technical identifier that is used for system purposes such as matching. If a suitable internal key is not available, a UUID <b>MAY</b> be used.</p>	Required CDA element.



NEHTA SCS Data Component	Data Component Definition	Card	CDA Schema Data Element	Vocab	Comments
REPORTING PATHOLOGIST > <b>Role</b>	The involvement or role of the participant in the related action from a healthcare perspective rather than the specific participation perspective.	1..1	author/assignedAuthor/ <b>code</b>	Role <b>SHOULD</b> have a value chosen from <a href="#">1220.0 - ANZSCO - Australian and New Zealand Standard Classification of Occupations, First Edition, Revision 1 [ABS2009]</a> .  However, if a suitable value in this set cannot be found, then any code set that is both registered with HL7 and publicly available <b>MAY</b> be used.	
REPORTING PATHOLOGIST > <b>Participant</b>	Details pertinent to the identification of an individual or organisation or device that has participated in a healthcare event/encounter/clinical interaction.	1..1	author/assignedAuthor/ <b>assignedPerson</b>		
REPORTING PATHOLOGIST > Participant > <b>Entity Identifier</b>	A number or code issued for the purpose of identifying a participant within a healthcare context.	1..*	author/assignedAuthor/assignedPerson/><Entity Identifier>	The value of one Entity Identifier <b>SHALL</b> be an Australian HPI-I.	See common pattern: <a href="#">Entity Identifier</a> .
REPORTING PATHOLOGIST > Participant > <b>Address</b>	The description of a location where an entity is located or can be otherwise reached or found and a description of the purpose for which that address is primarily used by that entity.	1..*	author/assignedAuthor/><Address>	AUSTRALIAN OR INTERNATIONAL ADDRESS <b>SHALL</b> be instantiated as an AUSTRALIAN ADDRESS.  Address Purpose (addr/@use) <b>SHALL</b> be set to Business (see <a href="#">AS 5017-2006: Health Care Client Identifier Address Purpose</a> ).	See common pattern: <a href="#">Address</a> .
REPORTING PATHOLOGIST > Participant > <b>Electronic Communication Detail</b>	The electronic communication details of entities.	1..*	author/assignedAuthor/><Electronic Communication Detail>	Electronic Communication Usage Code (telecom/@use) <b>SHALL</b> be set to Workplace (see <a href="#">HL7: TelecommunicationAddressUse</a> ).	See common pattern: <a href="#">Electronic Communication Detail</a> .
REPORTING PATHOLOGIST > Participant > <b>Person or Organisation or Device</b>	Represents a choice to be made at run-time between PERSON, ORGANISATION or DEVICE.	1..1	n/a	PERSON OR ORGANISATION OR DEVICE <b>SHALL</b> be instantiated as a PERSON.	This logical NEHTA data component has no mapping to CDA.  The cardinality of this component propagates to its children.
REPORTING PATHOLOGIST > Participant > Person or Organisation or Device > <b>Person</b>	An individual who is in the role of healthcare provider, who uses or is a potential user of a healthcare service, or is in some way related to, or a representative of, a subject of care (patient).	1..1	n/a		Not mapped directly; encompassed implicitly in author/assignedAuthor/assignedPerson.

NEHTA SCS Data Component	Data Component Definition	Card	CDA Schema Data Element	Vocab	Comments
REPORTING PATHOLOGIST > Participant > Person or Organisation or Device > Person > <b>Person Name</b>	The appellation by which an individual may be identified separately from any other within a social context.	1..*	author/assignedAuthor/assignedPerson/<Person Name>	Where the name of the REPORTING PATHOLOGIST is known but is not to be disclosed nullFlavor="MSK" is permitted.	See common pattern: <a href="#">Person Name</a> .
REPORTING PATHOLOGIST > Participant > Person or Organisation or Device > Person > <b>Employment Detail</b>	A person's occupation and employer.	1..1	author/assignedAuthor/assignedPerson/<Employment >		See common pattern: <a href="#">Employment</a> .
<b>CDA Body Level 3 Data Elements</b>			Context: ClinicalDocument/component/structuredBody/component[pathology]/section/		
REPORTING PATHOLOGIST > Participant > <b>Entitlement</b>	The entitlement or right of a participant to act in a given capacity (as defined by Entitlement Type) within a healthcare context.	0..*	ext:coverage2/@typeCode="COVBY"		
			ext:coverage2/ext:entitlement		
			ext:coverage2/ext:entitlement/@classCode="COV"		
			ext:coverage2/ext:entitlement/@moodCode="EVN"		
			ext:coverage2/ext:entitlement/ext:participant/@typeCode="HLD"		
			ext:coverage2/ext:entitlement/ext:participant/ext:participantRole/@classCode="ASSIGNED"		
			ext:coverage2/ext:entitlement/ext:participant/ext:participantRole/ext:id	UUID This is a technical identifier that is used for system purposes such as matching. If a suitable internal key is not available, a UUID <b>MAY</b> be used.	This <b>SHALL</b> hold the same value as component[pathology]/section/author/assignedAuthor/id.
REPORTING PATHOLOGIST > Participant > Entitlement > <b>Entitlement Number</b>	A number or code issued for the purpose of identifying the entitlement or right of a participant to act in a given capacity (as defined by Entitlement Type) within a healthcare context.	1..1	ext:coverage2/ext:entitlement/ext:id		See <id> for available attributes.
REPORTING PATHOLOGIST > Participant > Entitlement > <b>Entitlement Type</b>	The description of the scope of an entitlement.	1..1	ext:coverage2/ext:entitlement/ext:code	<a href="#">NCTIS: Admin Codes - Entitlement Type</a>	
REPORTING PATHOLOGIST > Participant > Entitlement > <b>Entitlement Validity Duration</b>	The time interval for which an entitlement is valid.	0..1	ext:coverage2/ext:entitlement/ext:effectiveTime		See <time> for available attributes.
<b>CDA Body Level 2 Data Elements</b>			Context: ClinicalDocument/component/structuredBody/component[pathology]/section/		
REPORTING PATHOLOGIST > Participant > <b>Qualifications</b>	A list of professional certifications, and certificates recognising having passed a course.	0..1	author/assignedAuthor/assignedPerson/ext:asQualifications		See NEHTA CDA extension: <a href="#">Qualifications</a> .  Qualifications is a text field, so the text list is entered in the originalText field of the code element.
			author/assignedAuthor/assignedPerson/ext:asQualifications/@classCode="QUAL"		
			author/assignedAuthor/assignedPerson/ext:asQualifications/ext:code/originalText		

**Example 7.9. REPORTING PATHOLOGIST XML Fragment**

<!-- This xml fragment is provided to demonstrate an example instance of each structured element in the CDA Mapping table. It is illustrative only. Logical model constraints on allowed combinations of child components are ignored in order to provide coverage of structured elements. This fragment cannot be treated as clinically valid. While the values in the fragment are conformant with the CDA Mapping table they are typically exaggerated to highlight the semantic meaning of the structured elements and may not be indicative of the expected values in a clinical document. While every effort has been taken to ensure that the examples are consistent with the message specification, where there are conflicts with the written message specification or schema, the specification or schema will take precedence. -->

```
<ClinicalDocument xmlns="urn:hl7-org:v3"
  xmlns:ext="http://ns.electronichealth.net.au/Ci/Cda/Extensions/3.0"
  ...
  >
  <!-- Begin CDA Header -->
  ...

  <!-- End CDA Header -->

  <!-- Begin CDA Body -->
  <component>
    <structuredBody>
      ...
      <!-- Begin PATHOLOGY -->
      <component>
        <section>
          ...
          <!-- Begin Narrative text -->
          <text>
            <table>
              <tbody>
                <tr>
                  <th>Australian Medicare Prescriber Number</th>
                  <td>049960CT</td>
                </tr>
              </tbody>
            </table>
          </text>
          <!-- End Narrative text -->

          <!-- Begin Reporting Pathologist Entitlement -->
          <ext:coverage2 typeCode="COVBY">
            <ext:entitlement classCode="COV" moodCode="EVN">
              <ext:id assigningAuthorityName="Medicare Prescriber number"
                root="1.2.36.174030967.0.3"
                extension="049960CT" />
              <ext:code code="10" codeSystem="1.2.36.1.2001.1001.101.104.16047"
                codeSystemName="NCTIS Entitlement Type Values"
                displayName="Medicare Prescriber Number" />
              <ext:effectiveTime>
                <low value="20050101"/>
                <high value="20250101"/>
              </ext:effectiveTime>
              <ext:participant typeCode="HLD">
                <ext:participantRole classCode="ASSIGNED">
                  <!-- Same as the prescriber (assignedAuthor) id -->
                  <ext:id root="7FCB0EC4-0CD0-11E0-9DFC-8F50DFD72085"/>
                </ext:participantRole>
              </ext:participant>
            </ext:entitlement>
          </ext:coverage2>
```

```
<!-- End Reporting Pathologist Entitlement -->
...
<!-- Begin REPORTING PATHOLOGIST -->
<author>
  <!-- DateTime Authored -->
  <time value="201110201235+1000" />

  <assignedAuthor>
    <!-- ID is used for system purposes such as matching -->
    <id root="7FCB0EC4-0CDD0-11E0-9DFC-8F50DFD72085" />

    <!-- Role -->
    <code code="253915" codeSystem="2.16.840.1.113883.13.62"
          codeSystemName="1220.0 - ANZSCO - Australian and New Zealand
          Standard Classification of Occupations, First Edition, Revision 1"
          displayName="Pathologist"/>

    <!-- Address -->
    <addr use="WP">
      <streetAddressLine>8 Pathology Street</streetAddressLine>
      <city>Nehtaville</city>
      <state>QLD</state>
      <postalCode>5555</postalCode>
      <additionalLocator>32568931</additionalLocator>
    </addr>

    <!-- Electronic Communication Detail -->
    <telecom use="WP" value="tel:0712341234" />

    <!-- Participant -->
    <assignedPerson>

      <!-- Person Name -->
      <name>
        <prefix>Dr</prefix>
        <given>Sean</given>
        <family>Grady</family>
      </name>

      <!-- Entity Identifier -->
      <ext:asEntityIdentifier classCode="IDENT">
        <ext:id assigningAuthorityName="HPI-I" root="1.2.36.1.2001.1003.0.8003619900015717"/>
        <ext:assigningGeographicArea classCode="PLC">
          <ext:name>National Identifier</ext:name>
        </ext:assigningGeographicArea>
      </ext:asEntityIdentifier>

      <!-- Employment Details -->
      <ext:asEmployment classCode="EMP">
        <!-- Position In Organisation -->
        <ext:code>
          <originalText>Pathologist</originalText>
        </ext:code>

        <!-- Occupation -->
        <ext:jobCode code="253915" codeSystem="2.16.840.1.113883.13.62"
              codeSystemName="1220.0 - ANZSCO - Australian and New Zealand
              Standard Classification of Occupations, First Edition,
              Revision 1"
              displayName="Pathologist" />

        <!-- Employment Type -->
```

```

<ext:jobClassCode code="FT" codeSystem="2.16.840.1.113883.5.1059" codeSystemName="HL7:EmployeeJobClass" displayName="full-time" />

<!-- Employer Organisation -->
<ext:employerOrganization>
  <!-- Department/Unit -->
  <name>Acme Hospital One</name>
  <asOrganizationPartOf>
    <wholeOrganization>
      <!-- Organisation Name -->
      <name use="ORGB">Acme Hospital Group</name>

      <!-- Entity Identifier (HPI-O) -->
      <ext:asEntityIdentifier classCode="IDENT">
        <ext:id assigningAuthorityName="HPI-O" root="1.2.36.1.2001.1003.0.8003621566684455" />
        <ext:assigningGeographicArea classCode="PLC">
          <ext:name>National Identifier</ext:name>
        </ext:assigningGeographicArea>
      </ext:asEntityIdentifier>

    </wholeOrganization>
  </asOrganizationPartOf>
</ext:employerOrganization>
</ext:asEmployment>

<ext:asQualifications classCode="QUAL">
  <ext:code>
    <originalText>M.B.B.S</originalText>
  </ext:code>
</ext:asQualifications>

</assignedPerson>
</assignedAuthor>
</author>
<!-- End REPORTING PATHOLOGIST -->
...
</section>
</component>
<!-- End PATHOLOGY -->

</structuredBody>
</component>
<!-- End CDA Body -->
</ClinicalDocument>

```

## 7.1.1.3 RELATED DOCUMENT

### Identification

Name	RELATED DOCUMENT
Metadata Type	Data Group
Identifier	DG-16971

### Relationships

#### Parent

Data Type	Name	Occurrences (child within parent)
	PATHOLOGY	0..1

## CDA R-MIM Representation

Figure 7.12 RELATED DOCUMENT shows a subset of the CDA R-MIM containing those classes being referred to in the CDA Mapping. This data component maps to CDA Body elements.

Each RELATED DOCUMENT data group is represented by an Act class related to its containing section by an entry relationship. Document Target is modelled as an external-Document relating to the containing act by a reference relationship (representing Link Nature). The id of the externalDocument represents Report Identifier. Report Status is modelled as Observation class related to the containing act by an entryRelationship. Report Name is modelled as an Act class related to the containing act by an entryRelationship.

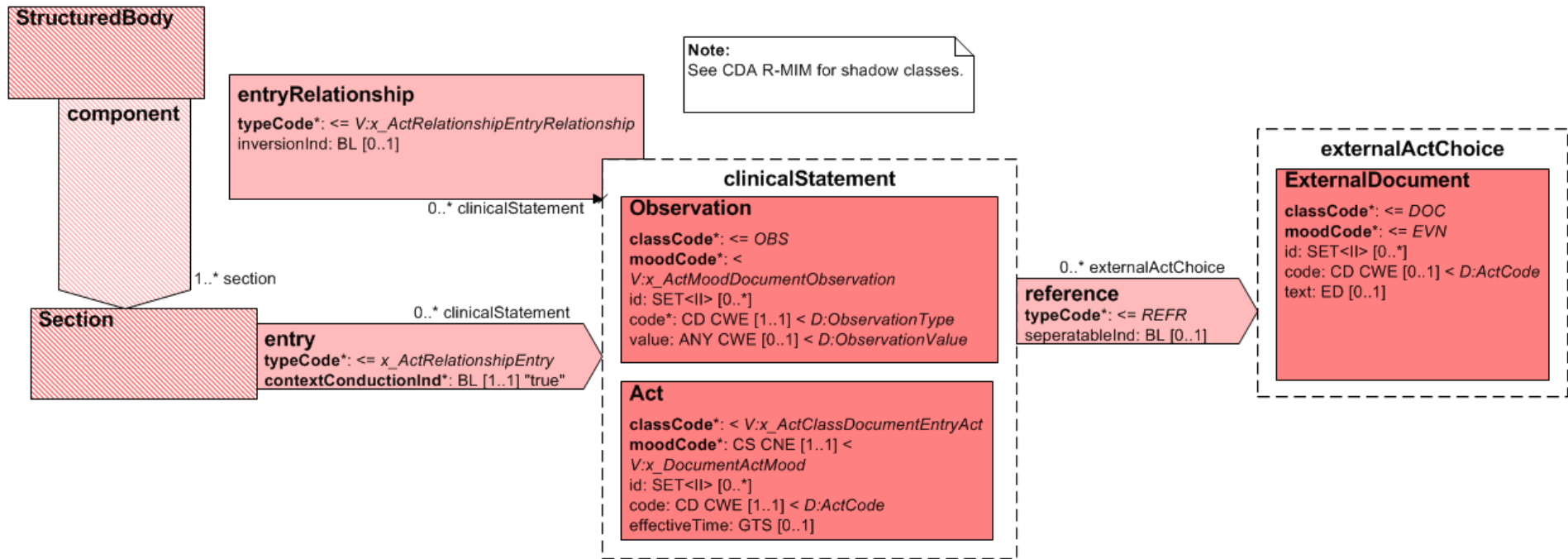

Figure 7.12. RELATED DOCUMENT

## CDA Mapping

NEHTA SCS Data Component	Data Component Definition	Card	CDA Schema Data Element	Vocab	Comments
<b>CDA Body Level 3 Data Elements</b>					
Context: ClinicalDocument/component/structuredBody/component[pathology]/section/					
RELATED DOCUMENT	Information about a document of interest.	0..1	entry[doc_detail]/@typeCode="COMP"		
			entry[doc_detail]/act		
			entry[doc_detail]/act/@classCode="ACT"		
			entry[doc_detail]/act/@moodCode="EVN"		
			entry[doc_detail]/act/id	UUID This is a technical identifier that is used for system purposes such as matching. If a suitable internal key is not available, a UUID <b>MAY</b> be used.	See <id> for available attributes.
			entry[doc_detail]/act/code		
			entry[doc_detail]/act/code/@code="102.16971"		
			entry[doc_detail]/act/code/@codeSystem="1.2.36.1.2001.1001.101"		
			entry[doc_detail]/act/code/@codeSystemName	The value <b>SHOULD</b> be "NCTIS Data Components". See <a href="#">CodeSystem OIDs</a> .	Optional CDA element.
entry[doc_detail]/act/code/@displayName="Related Document"					
RELATED DOCUMENT > Link Nature	The general semantic category of the relationship between this instance of this Detailed Clinical Model (DCM), i.e. the source, and the target DCM instance or target document.	1..1	entry[doc_detail]/act/reference[document]		LINK-E0 ("is a related documentation") is not mapped directly.
			entry[doc_detail]/act/reference[document]/seperatableInd/@value="true"		
RELATED DOCUMENT > Link Role	The detailed semantic description of the relationship between this instance of this DCM, i.e. the source, and the target DCM instance or target document.	1..1	entry[doc_detail]/act/reference[document]/@typeCode="XCRPT"		LINK-E4 ("excerpts") is mapped to typeCode="XCRPT".



NEHTA SCS Data Component	Data Component Definition	Card	CDA Schema Data Element	Vocab	Comments
RELATED DOCUMENT > <b>Test Result Representation (Document Target)</b>	The logical 'to' object in the link relation.	1..1	entry[doc_detail]/act/reference[document]/externalDocument		
			entry[doc_detail]/act/reference[document]/externalDocument/@classCode="DOC"		
			entry[doc_detail]/act/reference[document]/externalDocument/@moodCode="EVN"		
			entry[doc_detail]/act/reference[document]/externalDocument/text:ED		The link <b>SHALL</b> also be present in the corresponding CDA Narrative in a <linkHtml> element.
			entry[doc_detail]/act/reference[document]/externalDocument/text/@mediaType		The PCEHR system requires all Pathology Report with Structured Clinical Contents to use only PDF format files.
			entry[doc_detail]/act/reference[document]/externalDocument/text/@integrityCheck		
			entry[doc_detail]/act/reference[document]/externalDocument/text/reference		
			entry[doc_detail]/act/reference[document]/externalDocument/text/reference/@value		The file <b>SHALL</b> be one of the following formats: <ul style="list-style-type: none"> <li>• GIF (image/gif)</li> <li>• JPEG (image/jpg, image/jpeg)</li> <li>• PDF (application/pdf)</li> <li>• PNG (image/png)</li> <li>• TIFF (image/tif, image/tiff)</li> </ul>
RELATED DOCUMENT > <b>DOCUMENT DETAILS</b>	Information about a document of interest.	1..1	n/a		This logical NEHTA data component has no mapping to CDA.
RELATED DOCUMENT > DOCUMENT DETAILS > <b>Document Type</b>	Type of the document of interest.	1..1	entry[doc_detail]/act/reference[document]/externalDocument/code		
			entry[doc_detail]/act/reference[document]/externalDocument/code/@code="11526-1"		
			entry[doc_detail]/act/reference[document]/externalDocument/code/@codeSystem="2.16.840.1.113883.6.1"		
			entry[doc_detail]/act/reference[document]/externalDocument/code/@codeSystemName	The value <b>SHOULD</b> be "LOINC". See <a href="#">CodeSystem OIDs</a> .	Optional CDA element.
			entry[doc_detail]/act/reference[document]/externalDocument/code/@displayName="Pathology study"		

NEHTA SCS Data Component	Data Component Definition	Card	CDA Schema Data Element	Vocab	Comments
RELATED DOCUMENT > DOCUMENT DETAILS > <b>Report Name (Document Title)</b>	Title of the document of interest.	1..1	entry[doc_detail]/act/entryRelationship[title]/@typeCode="COMP"		
			entry[doc_detail]/act/entryRelationship[title]/act		
			entry[doc_detail]/act/entryRelationship[title]/act/@classCode="ACT"		
			entry[doc_detail]/act/entryRelationship[title]/act/@moodCode="EVN"		
			entry[doc_detail]/act/entryRelationship[title]/act/code		
			entry[doc_detail]/act/entryRelationship[title]/act/code/@code="103.16966"		
			entry[doc_detail]/act/entryRelationship[title]/act/code/@codeSystem="1.2.36.1.2001.1001.101"		
			entry[doc_detail]/act/entryRelationship[title]/act/code/@codeSystemName	The value <b>SHOULD</b> be "NCTIS Data Components". See <a href="#">CodeSystem OIDs</a> .	Optional CDA element.
			entry[doc_detail]/act/entryRelationship[title]/act/code/@displayName="Document Title"		
			entry[doc_detail]/act/entryRelationship[title]/act/text:ST		
RELATED DOCUMENT > DOCUMENT DETAILS > <b>Report DateTime (Effective Period)</b>	The period of time during which the document of interest is deemed to have clinical utility.	1..1	entry[doc_detail]/act/effectiveTime		
			entry[doc_detail]/act/effectiveTime/low		
			entry[doc_detail]/act/effectiveTime/low@value	The value <b>SHALL</b> include both a time and a date.	See <a href="#">&lt;time&gt;</a> for available attributes.
RELATED DOCUMENT > DOCUMENT DETAILS > <b>Report Identifier (Document Identifier)</b>	Unique identifier of the document of interest.	1..1	entry[doc_detail]/act/reference[document]/externalDocument/id	<p>UUID</p> <p>This is a technical identifier that is used for system purposes such as matching. If a suitable internal key is not available, a UUID <b>MAY</b> be used.</p>	<p>See common pattern: <a href="#">id</a>.</p> <p>The <a href="#">HPI-O based Report Identifier</a><sup>10</sup> is provided as a default option; if the organisation has some other OID to use to identify the Local System Identifier, then that OID should be used instead.</p> <p>The <a href="#">HPI-O based Report Identifier</a> can be used as the root of an arc that organisations can use for their own local report IDs. This OID is never used directly; the 16 digit HPI-O is appended to the OID (i.e. 1.2.36.1.2001.1005.54.[HPI-O]) as the value of id/@root to identify that organisation's local order identifier which is the value of id/@extension.</p>

<sup>10</sup> [https://www.hl7.org/oid/index.cfm?Comp\\_OID=1.2.36.1.2001.1005.54](https://www.hl7.org/oid/index.cfm?Comp_OID=1.2.36.1.2001.1005.54)

NEHTA SCS Data Component	Data Component Definition	Card	CDA Schema Data Element	Vocab	Comments
RELATED DOCUMENT > DOCUMENT DETAILS > Report Status (Document Status)	Status of the document of interest.	1..1	entry[doc_detail]/act/entryRelationship[status]/@typeCode="COMP"		
			entry[doc_detail]/act/entryRelationship[status]/observation		
			entry[doc_detail]/act/entryRelationship[status]/observation/@classCode="OBS"		
			entry[doc_detail]/act/entryRelationship[status]/observation/@moodCode="EVN"		
			entry[doc_detail]/act/entryRelationship[status]/observation/code		
			entry[doc_detail]/act/entryRelationship[status]/observation/code/@code="103.20104"		
			entry[doc_detail]/act/entryRelationship[status]/observation/code/@codeSystem="1.2.36.1.2001.1001.101"		
			entry[doc_detail]/act/entryRelationship[status]/observation/code/@codeSystemName	The value <b>SHOULD</b> be "NCTIS Data Components". See <a href="#">CodeSystem OIDs</a> .	Optional CDA element.
			entry[doc_detail]/act/entryRelationship[status]/observation/code/@displayName="Document Status"		
entry[doc_detail]/act/entryRelationship[status]/observation/value:CD	<a href="#">HL7: Result Status</a>	See <code> for available attributes.			

## Example 7.10. RELATED DOCUMENT XML Fragment

<!-- This xml fragment is provided to demonstrate an example instance of each structured element in the CDA Mapping table. It is illustrative only. Logical model constraints on allowed combinations of child components are ignored in order to provide coverage of structured elements. This fragment cannot be treated as clinically valid. While the values in the fragment are conformant with the CDA Mapping table they are typically exaggerated to highlight the semantic meaning of the structured elements and may not be indicative of the expected values in a clinical document. While every effort has been taken to ensure that the examples are consistent with the message specification, where there are conflicts with the written message specification or schema, the specification or schema will take precedence. -->

```
<ClinicalDocument xmlns="urn:hl7-org:v3"
  xmlns:ext="http://ns.electronichealth.net.au/Ci/Cda/Extensions/3.0"
  ...
  >
  ...
  <!-- Begin CDA Header -->
  ...
  <!-- End CDA Header -->
  ...
  <!-- Begin CDA Body -->
  <component>
    <structuredBody>
      ...
      <!-- Begin PATHOLOGY -->
      <component typeCode="COMP">
        <section classCode="DOCSECT" moodCode="EVN">
          ...
          <!-- Begin Narrative text -->
          <text>
            <paragraph>
              <linkHtml href="attachment.pdf">Attached Report</linkHtml>
            </paragraph>
          </text>
          <!-- End Narrative text -->
          ...
          <!-- Begin RELATED DOCUMENT -->
          <entry typeCode="COMP">
            <act classCode="ACT" moodCode="EVN">
              <!-- Technical Identifier to uniquely identify this act -->
              <id root="31c45290-2883-11e2-81c1-080000c9a67"/>
              <code code="102.16971" codeSystem="1.2.36.1.2001.1001.101"
                codeSystemName="NCTIS Data Components"
                displayName="Related Document"/>
              ...
              <!-- Begin Report DateTime (Effective Period) -->
              <effectiveTime>
                <low value="201004271235+1000"/>
              </effectiveTime>
              <!-- End Report DateTime (Effective Period) -->
              ...
              <!-- Begin Link Nature / Link Role-->
              <reference typeCode="XCRPT">
                <seperatableInd value="true"/>
              <!-- End Link Nature / Link Role -->
              ...
              <!-- Begin Test Result Representation (Document Target) -->
              <externalDocument classCode="DOC" moodCode="EVN">
                <!-- Report Identifier (Document Identifier) -->
```

```

<id extension="123451" root="1.2.36.1.2001.1005.54.8003621231166549" />
<!-- example showing root="[HPI-O based Report Identifier OID][HPI-O]". Local report identifier value used in extension -->

<!-- Document Type -->
<code code="11526-1"
      codeSystem="2.16.840.1.113883.6.1"
      codeSystemName="LOINC"
      displayName="Pathology study" />

<!-- attachment as encapsulated data -->
<text integrityCheck="IiZnLy4gyewfICeWhFe2NcDDw="
      mediaType="application/pdf">
  <reference value="attachment.pdf"/>
</text>

</externalDocument>
<!-- End Test Result Representation (Document Target) -->
</reference>

<!-- Begin Report Name (Document Title) -->
<entryRelationship typeCode="COMP">
  <act classCode="ACT" moodCode="EVN">
    <code code="103.16966"
          codeSystem="1.2.36.1.2001.1001.101"
          codeSystemName="NCTIS Data Components"
          displayName="Document Title"/>
    <text xsi:type="ST">Full blood count</text>
  </act>
</entryRelationship>
<!-- End Report Name (Document Title) -->

<!-- Begin Report Status (Document Status) -->
<entryRelationship typeCode="COMP">
  <observation classCode="OBS" moodCode="EVN">
    <code code="103.20104"
          codeSystem="1.2.36.1.2001.1001.101"
          codeSystemName="NCTIS Data Components"
          displayName="Document Status"/>
    <value code="F"
           codeSystem="2.16.840.1.113883.12.123"
           codeSystemName="HL7 Result Status"
           displayName="Final results; results stored and verified. Can only be changed with a corrected result." xsi:type="CD"/>
  </observation>
</entryRelationship>
<!-- End Report Status (Document Status) -->

</act>
</entry>
<!-- End RELATED DOCUMENT -->
...

</section>
</component>
<!-- End PATHOLOGY -->
...

</structuredBody>
</component>
<!-- End CDA Body -->

</ClinicalDocument>

```

# 8 Common Patterns

## 8.1 code

The <code> element pattern refines the kind of act being recorded. It is of data type CD CWE (Concept Descriptor, Coded With Extensibility). It may have:

- a null attribute (*nullFlavor*)
- *originalText*
- *code* and *codeSystem*
- *translation* (CD)
- any combination of the above.

A *displayName* is highly recommended.

Where used, the *code* attribute **SHALL** contain a code from the relevant vocabulary.

Where used, the *codeSystem* attribute **SHALL** contain the OID for the relevant vocabulary. Values for coding systems can be obtained from the HL7 OID registry accessible from the HL7 home web page at [www.hl7.org](http://www.hl7.org)<sup>1</sup>.

Where used, the *displayName* attribute **SHALL** contain a human-readable description of the code value.

The *codeSystemName* **MAY** be present and, where used, **SHALL** contain a human-readable name for the coding system.

Where used, the *originalText* element **SHALL** be used to carry the full text associated with this code as selected by, typed by or displayed to the author of this statement.

Codes can be obtained from a variety of sources. Additional vocabularies are also available from the HL7 Version 3 Vocabulary tables, available to HL7 members through the HL7 web site. In some cases, the vocabularies have been specified; in others, a particular code has been fixed or there is no vocabulary specified.

If a vocabulary is specified in this implementation guide and no suitable code can be found, the *originalText* element **SHALL** be used to carry the full text as selected by, typed by or displayed to the author of this statement.

<sup>1</sup> <http://www.hl7.org>

If a vocabulary is specified in this implementation guide and it is not possible to use this vocabulary, but an alternate vocabulary is in use, the *originalText* element **SHALL** be used to carry the full text as selected by, typed by or displayed to the author of this statement. The *code* element **SHALL** be used to carry the relevant information from the alternate vocabulary and the alternate vocabulary **SHALL** be registered with HL7 and allocated an appropriate OID.

If an alternate vocabulary is in use and a translation into the specified code system is available, the *originalText* element **SHALL** be used to carry the full text as selected by, typed by or displayed to the author of this statement. The *code* element **SHALL** be used to carry the relevant information from the alternate vocabulary and the alternate vocabulary **SHALL** be registered with HL7 and allocated an appropriate OID. The *translation* element **SHALL** be used to indicate the translation code from the specified vocabulary.

### Example 8.1. code

```
<!-- Specified code system in use -->
<code
  code="271807003"
  codeSystem="2.16.840.1.113883.6.96"
  codeSystemName="SNOMED CT"
  codeSystemVersion="20101130"
  displayName="skin rash" />

<!-- Alternate code system in use and a translation into the specified code system is available -->
<code
  code="J45.9"
  codeSystem="2.16.840.1.113883.6.135"
  codeSystemName="icd10am"
  displayName="Asthma, unspecified">
  <originalText>Asthma</originalText>
  <translation
    code="195967001"
    codeSystem="2.16.840.1.113883.6.96"
    codeSystemName="SNOMED CT"
    displayName="Asthma"/>
</code>

<!-- Alternate code system in use and no translation into the specified code system is available -->
<code
  code="J45.9"
  codeSystem="2.16.840.1.113883.6.135"
  codeSystemName="icd10am"
  displayName="Asthma, unspecified">
  <originalText>Asthma</originalText>
</code>

<!-- No suitable code can be found or there is no code system in use -->
<code
  <originalText>Asthma</originalText>
</code>
```

## 8.2 id

The <id> element pattern is of data type II (Instance Identifier). The II data type may have:

- a null attribute (*nullFlavor*)
- a *root*
- a *root* and an *extension*
- a *root* and an *extension* and an *assigningAuthorityName*
- a *root* and an *assigningAuthorityName*
- a *root* and an *assigningAuthorityName* and a *displayable*
- a *root* and an *extension* and a *displayable*
- a *root* and an *extension* and an *assigningAuthorityName* and a *displayable*
- a *root* and a *displayable*

The root attribute is **REQUIRED** and is a unique identifier that guarantees the global uniqueness of the instance identifier. The root alone **MAY** be the entire instance identifier. The root attribute **SHALL** be a UUID or OID.

The extension attribute **MAY** be present, and is a character string as a unique identifier within the scope of the identifier root.

In the case of Entity Identifier, *assigningAuthorityName* is **RECOMMENDED**.

Identifiers appear in this implementation guide for two different reasons. The first is that the identifier has been identified in the business requirements as relevant to the business process. These identifiers are documented in the SCSs, which make clear the meaning of this identifier.

In addition, the implementation makes clear that identifiers may also be found on many other parts of the CDA content model. These identifiers are allowed to facilitate record matching across multiple versions of related documents, so that the same record can consistently be identified, in spite of variations in the information as the record passes through time or between systems. These identifiers have no meaning in the business specification. If senders provide one of these identifiers, it **SHALL** always be the same identifier in all versions of the record, and it **SHALL** be globally unique per the rules of the II data type.

Throughout the specification, these identifiers are labelled with the following text: "This is a technical identifier that is used for system purposes such as matching."



**Example 8.2. id**

```
<id root="2.16.840.1.113883.19" extension="123A45" />  
<ext:id assigningAuthorityName="HPI-O" root="1.2.36.1.2001.1003.0.8003621566684455" />
```

## 8.3 time

When a time value is supplied it **SHALL** include hours and minutes.

When a time value is supplied it **MAY** include seconds and fractions of seconds.

When a time value is supplied it **SHALL** include a time zone.

The <time> element pattern is of data type TS (Point in Time) and can also be an interval between two times (IVL\_TS), representing a period of time. Both forms can either have a nullFlavor attribute or child components following allowed patterns.

A simple timestamp (point in time) will only contain a value attribute containing the time value, expressed as a series of digits as long as required or as available.

### Example 8.3. Simple timestamp

```
<time value="20091030" />
```

This represents "October 30, 2009" to calendar day precision. In cases where the containing element is defined in the CDA schema as "ANY" data type, it is useful to provide an xsi:type attribute, set to the value "TS".

The period of time pattern is defined in terms of one or both of its lowest and highest values. The low and high elements are instances of the timestamp pattern described above. More complex time period concepts can be expressed by combining a high, low, or centre element with a width element.

### Example 8.4. Low time

```
<period>  
  <low value="20091030" />  
</period>
```

This represents "a period after October 30, 2009". In cases where the containing element is defined in the CDA schema as "ANY" data type, it is useful to provide an xsi:type attribute, set to the value "IVL\_TS", as in the next example.

### Example 8.5. Interval timestamp 1

```
<period xsi:type="IVL_TS">  
  <high value="200910301030+1000" />  
</period>
```

This represents "a period before 10:30 a.m. UTC+10, October 30, 2009". A discretionary xsi:type attribute has been provided to explicitly cast the pattern to "IVL\_TS".

### Example 8.6. Interval timestamp 2

```
<period xsi:type="IVL_TS">  
  <low value="2007" />  
  <high value="2009" />  
</period>
```

This represents "the calendar years between 2007 and 2009". The low element **SHALL** precede the high element. As per the previous example, a discretionary xsi:type attribute has been provided to explicitly cast the pattern to "IVL\_TS".

### Example 8.7. Width time

```
<period>  
  <high value="20091017" />  
  <width value="2" unit="wk" />  
</period>
```

This expresses "two weeks before October 17th, 2009". A low value can be derived from this.

## 8.4 Entity Identifier

### CDA Mapping

NEHTA SCS Data Component	Data Component Definition	Card	CDA Schema Data Element	Vocab	Comments
<b>CDA Data Elements</b>					
<b>Entity Identifier</b>	A number or code issued for the purpose of identifying an entity (person, organisation or organisation sub-unit) within a healthcare context.	The cardinality of the group comes from the linking parent and the cardinality of the children data elements comes from the R-MIM diagram.	<b>ext:asEntityIdentifier</b>		See NEHTA CDA extension: <a href="#">Entity-Identifier</a> .
			ext:asEntityIdentifier/@classCode="IDENT"		
			ext:asEntityIdentifier/ext:id		
			ext:asEntityIdentifier/ext:id/@root	Attribute @root <b>SHALL</b> be used, <b>SHALL</b> be an OID and <b>SHALL NOT</b> be a UUID.  Attribute @root <b>SHALL</b> be a globally unique object identifier (i.e. OID) that identifies the combination of geographic area, issuer and type. If no such OID exists, it <b>SHALL</b> be defined before any identifiers can be created.	
			ext:asEntityIdentifier/ext:id/@extension	Attribute @extension <b>MAY</b> be used and, if it is used, <b>SHALL</b> be a unique identifier within the scope of the root that is populated directly from the designation.	
			ext:asEntityIdentifier/ext:id/@assigningAuthorityName	Attribute @assigningAuthorityName <b>SHOULD</b> be used and, if it is used, <b>SHALL</b> be a human-readable name for the namespace represented in the root that is populated with the issuer, or identifier type, or a concatenation of both as appropriate. This <b>SHOULD NOT</b> be used for machine readability purposes.	
			ext:asEntityIdentifier/ext:code		See <code> for available attributes.
			ext:asEntityIdentifier/ext:assigningGeographicArea		
			ext:asEntityIdentifier/ext:assigningGeographicArea/@classCode="PLC"		
ext:asEntityIdentifier/ext:assigningGeographicArea/ext:name	Element ext:name <b>MAY</b> be used and, if it is used, <b>SHALL</b> be the range and extent that the identifier applies to the object with which it is associated that is populated directly from the geographic area. This <b>SHOULD NOT</b> be used for machine readability purposes.  For details see: <a href="#">AS 5017-2006: Health Care Client Identifier Geographic Area</a> .				

## Example 8.8. Entity Identifier

<!-- This xml fragment is provided to demonstrate an example instance of each structured element in the CDA Mapping table. It is illustrative only. Logical model constraints on allowed combinations of child components are ignored in order to provide coverage of structured elements. This fragment cannot be treated as clinically valid. While the values in the fragment are conformant with the CDA Mapping table they are typically exaggerated to highlight the semantic meaning of the structured elements and may not be indicative of the expected values in a clinical document. While every effort has been taken to ensure that the examples are consistent with the message specification, where there are conflicts with the written message specification or schema, the specification or schema will take precedence. -->

```
<!-- person -->
<xs:asEntityIdentifier classCode="IDENT">
  <xs:id root="1.2.36.1.2001.1003.0.8003608833357361" assigningAuthorityName="IHI" />
  <xs:assigningGeographicArea classCode="PLC">
    <xs:name>National Identifier</xs:name>
  </xs:assigningGeographicArea>
</xs:asEntityIdentifier>

<xs:asEntityIdentifier classCode="IDENT">
  <xs:id root="1.2.36.1.2001.1005.29.8003621566684455" extension="542181" assigningAuthorityName="Croydon GP Centre" />
  <xs:code code="MR" codeSystem="2.16.840.1.113883.12.203" codeSystemName="Identifier Type (HL7)" />
</xs:asEntityIdentifier>

<!-- organisation -->
<ext:asEntityIdentifier classCode="IDENT">
  <ext:id assigningAuthorityName="HPI-0" root="1.2.36.1.2001.1003.0.8003621566684455" />
  <ext:assigningGeographicArea classCode="PLC">
    <ext:name>National Identifier</ext:name>
  </ext:assigningGeographicArea>
</ext:asEntityIdentifier>
```

## 8.5 Person Name

### CDA Mapping

NEHTA SCS Data Component	Data Component Definition	Card	CDA Schema Data Element	Vocab	Comments
<b>CDA Data Elements</b>					
<b>Person Name</b>	The appellation by which an individual may be identified separately from any other within a social context.	Cardinality comes from linking parent.	<b>name</b>		
Person Name > <b>Name Title</b>	An honorific form of address commencing a name.	0..*	name/ <b>prefix</b>		
Person Name > <b>Family Name</b>	That part of a name a person usually has in common with some other members of his/her family, as distinguished from his/her given names.	1..1	name/ <b>family</b>		
Person Name > <b>Given Name</b>	The person's identifying names within the family group or by which the person is uniquely socially identified.	0..*	name/ <b>given</b>		
Person Name > <b>Name Suffix</b>	The additional term used following a person's name to identify that person.	0..*	name/ <b>suffix</b>		
Person Name > <b>Preferred Name Indicator</b>	A flag to indicate that this is the name a person has selected for use.	0..1	name/ <b>@use</b>	A code for representing "preferred name" has been requested from HL7 International but is not currently available.	If both Preferred Name Indicator and Person Name Usage have been provided, the use attribute <b>SHALL</b> include them as space separated list of codes.
Person Name > <b>Person Name Usage</b>	The classification that enables differentiation between recorded names for a person.	0..1	name/ <b>@use</b>	<a href="#">AS 5017-2006: Health Care Client Name Usage</a>	If both Preferred Name Indicator and Person Name Usage have been provided, the use attribute <b>SHALL</b> include them as space separated list of codes.

## Example 8.9. Person Name

```
<!-- This xml fragment is provided to demonstrate an example instance of each structured element in the CDA Mapping table. It is illustrative only.
Logical model constraints on allowed combinations of child components are ignored in order to provide coverage of structured elements. This fragment cannot be treated as clinically valid.
While the values in the fragment are conformant with the CDA Mapping table they are typically exaggerated to highlight the semantic meaning of the structured elements and
may not be indicative of the expected values in a clinical document.
While every effort has been taken to ensure that the examples are consistent with the message specification, where there are conflicts with the written message specification or schema,
the specification or schema will take precedence. -->
```

```
<!-- preferred name -->
<name use="L">
  <prefix>Ms</prefix>
  <given>Sally</given>
  <family>Grant</family>
</name>
```

## 8.6 Address

### CDA Mapping

NEHTA SCS Data Component	Data Component Definition	Card	CDA Schema Data Element	Vocab	Comments
<b>CDA Data Elements</b>					
<b>Address</b>	The description of a location where an entity is located or can be otherwise reached or found and a description of the purpose for which that address is primarily used by that entity.	Cardinality comes from linking parent.	<b>addr</b>		<p>In an event where the Address of the Subject of Care is 'Unknown' or 'Masked / Not to be disclosed for privacy reason', the following conditions <b>SHOULD</b> be applied.</p> <p>The nullFlavor = "UNK" <b>SHOULD</b> be permitted if the value of address is not known and the value of 'No Fixed Address Indicator' is false.</p> <p>The nullFlavor = "MSK" <b>SHOULD</b> be permitted if the value of address is masked and the value of 'No Fixed Address Indicator' is false.</p> <p>The nullFlavor = "NA" <b>SHOULD</b> be permitted if value of 'No Fixed Address Indicator' is true. (This is the same as the current CDA IG constraint).</p> <p>The value of the &lt;addr&gt; data group <b>SHALL</b> be populated in all other circumstances.</p>
Address > <b>No Fixed Address Indicator</b>	A flag to indicate whether or not the participant has no fixed address.	1..1	addr/@nullFlavor		If true, nullFlavor="NA". If false omit nullFlavor and fill in address.



NEHTA SCS Data Component	Data Component Definition	Card	CDA Schema Data Element	Vocab	Comments
Address > <b>Australian or International Address</b>	Represents a choice to be made at run-time between an AUSTRALIAN ADDRESS and an INTERNATIONAL ADDRESS.	1..1	n/a		This logical NEHTA data component has no mapping to CDA.  The cardinality of this component propagates to its children.
Address > Australian or International Address > <b>International Address</b>	The description of a non-Australian location where an entity is located or can be otherwise reached or found.	0..1	n/a		This logical NEHTA data component has no mapping to CDA.  The cardinality of this component propagates to its children.
Address > Australian or International Address > International Address > <b>International Address Line</b>	A composite of address details comprising a low level geographical/physical description of a location that, used in conjunction with the other high level address components, i.e. international state/province, international post-code and country, forms a complete geographic/physical address.	0..*	addr/streetAddressLine		
Address > Australian or International Address > International Address > <b>International State/Province</b>	The designation applied to an internal, political or geographic division of a country other than Australia that is officially recognised by that country.	0..1	addr/state		
Address > Australian or International Address > International Address > <b>International Postcode</b>	The alphanumeric descriptor for a postal delivery area (as defined by the postal service of a country other than Australia) aligned with locality, suburb or place for an address.	0..1	addr/postalCode		
Address > Australian or International Address > International Address > <b>Country</b>	The country component of the address.	0..1	addr/country	Australia Bureau of Statistics, Standard Australian Classification of Countries (SACC) Cat. No. 1269 <a href="#">[ABS2008]</a>	Use the name, not the numbered code.
Address > Australian or International Address > <b>Australian Address</b>	The description of an Australian location where an entity is located or can be otherwise reached or found.	0..1	n/a		This logical NEHTA data component has no mapping to CDA.  The cardinality of this component propagates to its children.
Address > Australian or International Address > Australian Address > <b>Unstructured Australian Address Line</b>	A composite of one or more low level standard address components describing a geographical/physical location that, used in conjunction with the other high level address components, e.g. Australian suburb/town/locality name, Australian postcode and Australian State/Territory, forms a complete geographical/physical address.	0..*	addr/streetAddressLine		

NEHTA SCS Data Component	Data Component Definition	Card	CDA Schema Data Element	Vocab	Comments
Address > Australian or International Address > Australian Address > <b>Structured Australian Address Line</b>	The standard low level address components describing a geographical/physical location that, used in conjunction with the other high level address components, i.e. Australian suburb/ town/locality name, Australian postcode and Australian State/Territory, form a complete geographical/physical address.	0..1	n/a		This logical NEHTA data component has no mapping to CDA.  The cardinality of this component propagates to its children.
Address > Australian or International Address > Australian Address > Structured Australian Address Line > <b>Australian Unit Type</b>	The specification of the type of a separately identifiable portion within a building/complex, marina etc. to clearly distinguish it from another.	0..1	addr/unitType	AS 5017 (2006) - Healthcare Client Identification: Australian Unit Type [SA2006a]  AS 4846 (2006) - Healthcare Provider Identification: Australian Unit Type [SA2006b]	
Address > Australian or International Address > Australian Address > Structured Australian Address Line > <b>Australian Unit Number</b>	The specification of the number or identifier of a building/complex, marina etc. to clearly distinguish it from another.	0..1	addr/unitID		
Address > Australian or International Address > Australian Address > Structured Australian Address Line > <b>Australian Address Site Name</b>	The full name used to identify the physical building or property as part of its location.	0..1	addr/additionalLocator		
Address > Australian or International Address > Australian Address > Structured Australian Address Line > <b>Australian Level Type</b>	Descriptor used to classify the type of floor or level of a multistorey building/complex.	0..1	addr/additionalLocator	AS 5017 (2006) - Healthcare Client Identification: Australian Level Type [SA2006a]  AS 4846 (2006) - Healthcare Provider Identification: Australian Level Type [SA2006b]	
Address > Australian or International Address > Australian Address > Structured Australian Address Line > <b>Australian Level Number</b>	Descriptor used to identify the floor or level of a multistorey building/complex.	0..1	addr/additionalLocator		
Address > Australian or International Address > Australian Address > Structured Australian Address Line > <b>Australian Street Number</b>	The numeric or alphanumeric reference number of a house or property that is unique within a street name.	0..1	addr/houseNumber		
Address > Australian or International Address > Australian Address > Structured Australian Address Line > <b>Australian Lot Number</b>	The Australian Lot reference allocated to an address in the absence of street numbering.	0..1	addr/additionalLocator		
Address > Australian or International Address > Australian Address > Structured Australian Address Line > <b>Australian Street Name</b>	The name that identifies a public thoroughfare and differentiates it from others in the same suburb/town/locality.	0..1	addr/streetName		

NEHTA SCS Data Component	Data Component Definition	Card	CDA Schema Data Element	Vocab	Comments
Address > Australian or International Address > Australian Address > Structured Australian Address Line > <b>Australian Street Type</b>	A code that identifies the type of public thoroughfare.	0..1	addr/streetNameType	AS 5017 (2006) - Healthcare Client Identification: Australian Street Type Code [SA2006a] AS 4846 (2006) - Healthcare Provider Identification: Australian Street Type Code [SA2006b]	
Address > Australian or International Address > Australian Address > Structured Australian Address Line > <b>Australian Street Suffix</b>	Term used to qualify Australian Street Name used for directional references.	0..1	addr/direction	AS 5017 (2006) - Healthcare Client Identification: Australian Street Suffix [SA2006a] AS 4846 (2006) - Healthcare Provider Identification: Australian Street Suffix [SA2006b]	
Address > Australian or International Address > Australian Address > Structured Australian Address Line > <b>Australian Postal Delivery Type</b>	Identification for the channel of postal delivery.	0..1	addr/deliveryAddressLine	AS 5017 (2006) - Healthcare Client Identification: Australian Postal Delivery Type Code [SA2006a] AS 4846 (2006) - Healthcare Provider Identification: Australian Postal Delivery Type Code [SA2006b]	
Address > Australian or International Address > Australian Address > Structured Australian Address Line > <b>Australian Postal Delivery Number</b>	Identification number for the channel of postal delivery.	0..1	addr/deliveryAddressLine		
Address > Australian or International Address > Australian Address > <b>Australian Suburb/Town/Locality</b>	The full name of the general locality contained within the specific address.	0..1	addr/city	Values in this data element should comply with descriptions in the Australia Post Postcode File (see <a href="http://www.auspost.com.au/postcodes">www.auspost.com.au/postcodes</a> ).	
Address > Australian or International Address > Australian Address > <b>Australian State/Territory</b>	The identifier of the Australian state or territory.	0..1	addr/state	<a href="#">AS 5017-2006 Australian State/Territory Identifier - Postal</a>	
Address > Australian or International Address > Australian Address > <b>Australian Postcode</b>	The numeric descriptor for a postal delivery area (as defined by Australia Post), aligned with locality, suburb or place for the address.	0..1	addr/postalCode	Values in this data element should comply with descriptions in the Australia Post Postcode File (see <a href="http://www.auspost.com.au/postcodes">www.auspost.com.au/postcodes</a> ).	
Address > Australian or International Address > Australian Address > <b>Australian Delivery Point Identifier</b>	A unique number assigned to a postal delivery point as recorded on the Australia Post Postal Address File.	0..1	addr/additionalLocator		
Address > <b>Address Purpose</b>	The purpose for which the address is being used by the entity.	1..1	addr/@use	<a href="#">AS 5017-2006: Health Care Client Identifier Address Purpose</a>	Space separated list of codes.

## Example 8.10. Address

<!-- This xml fragment is provided to demonstrate an example instance of each structured element in the CDA Mapping table. It is illustrative only. Logical model constraints on allowed combinations of child components are ignored in order to provide coverage of structured elements. This fragment cannot be treated as clinically valid. While the values in the fragment are conformant with the CDA Mapping table they are typically exaggerated to highlight the semantic meaning of the structured elements and may not be indicative of the expected values in a clinical document. While every effort has been taken to ensure that the examples are consistent with the message specification, where there are conflicts with the written message specification or schema, the specification or schema will take precedence. -->

```
<!-- no fixed address -->
<addr nullFlavor="NA" />
```

```
<!--Australian home address (unstructured) -->
<addr use="H">
  <streetAddressLine>1 Clinician Street</streetAddressLine>
  <city>Nehtaville</city>
  <state>QLD</state>
  <postalCode>5555</postalCode>
  <additionalLocator>32568931</additionalLocator>
</addr>
```

```
<!--Australian business address (structured) -->
<addr use="WP">
  <houseNumber>1</houseNumber>
  <streetName>Clinician</streetName>
  <streetNameType>St</streetNameType>
  <city>Nehtaville</city>
  <state>QLD</state>
  <postalCode>5555</postalCode>
  <additionalLocator>32568931</additionalLocator>
</addr>
```

```
<!--international postal address -->
<addr use="PST">
  <streetAddressLine>51 Clinician Bay</streetAddressLine>
  <city>Healthville</city>
  <state>Manitoba</state>
  <postalCode>R3T 3C6</postalCode>
  <country>Canada</country>
</addr>
```

## 8.7 Electronic Communication Detail

### CDA Mapping

NEHTA SCS Data Component	Data Component Definition	Card	CDA Schema Data Element	Vocab	Comments
<b>CDA Data Elements</b>					
<b>Electronic Communication Detail</b>	The electronic communication details of entities.	Cardinality comes from linking parent.	<b>telecom</b>		
Electronic Communication Detail > <b>Electronic Communication Medium</b>	A code representing a type of communication mechanism.	1..1	telecom/@value	AS 5017-2006: Health Care Client Electronic Communication Medium > HL7:URLScheme	Makes up part of the value attribute as 'tel:phone number', 'mailto:email address', 'http:URL', etc.
Electronic Communication Detail > <b>Electronic Communication Usage Code</b>	The manner of use that is applied to an electronic communication medium.	0..1	telecom/@use	HL7: TelecommunicationAddressUse > HL7:TelecommunicationAddressUse	Space separated list of codes.  The section <a href="#">AS 5017-2006: Health Care Client Electronic Communication Usage Code</a> explains how to map AS 5017-2006 to HL7 Telecommunication-AddressUse (HL7 TAU) code
Electronic Communication Detail > <b>Electronic Communication Address</b>	A unique combination of characters used as input to electronic telecommunication equipment for the purpose of contacting an entity.	1..1	telecom/@value		Makes up part of the value attribute as 'tel:phone number', 'mailto:email address', 'http:URL', etc.

## Example 8.11. Electronic Communication Detail

<!-- This xml fragment is provided to demonstrate an example instance of each structured element in the CDA Mapping table. It is illustrative only. Logical model constraints on allowed combinations of child components are ignored in order to provide coverage of structured elements. This fragment cannot be treated as clinically valid. While the values in the fragment are conformant with the CDA Mapping table they are typically exaggerated to highlight the semantic meaning of the structured elements and may not be indicative of the expected values in a clinical document. While every effort has been taken to ensure that the examples are consistent with the message specification, where there are conflicts with the written message specification or schema, the specification or schema will take precedence. -->

```
<!--home telephone number -->
<telecom value="tel:0499999999" use="H" />

<!--pager -->
<telecom value="tel:0499999999" use="PG" />

<!--home email address -->
<telecom value="mailto:clinicial@clinician.com" use="H" />
```

## 8.8 Employment

### CDA Mapping



#### Note

NS = In the absence of national standard code sets, the code sets used **SHALL** be registered code sets, i.e. registered through the [HL7 code set registration procedure](#)<sup>2</sup> with an appropriate object identifier (OID), and **SHALL** be publicly available.

When national standard code sets become available, they **SHALL** be used and the non-standard code sets **SHALL** be deprecated.

NEHTA SCS Data Component	Data Component Definition	Card	CDA Schema Data Element	Vocab	Comments
<b>CDA Data Elements</b>					
<b>Employment Detail</b>	A person's occupation and employer.	Cardinality comes from linking parent.	n/a		This logical NEHTA data component has no mapping to CDA.
Employment Detail > <b>Employer Organization</b>	The organisation that the individual is working for in respect to the role they are playing in the nominated participation.	1..*	<b>ext:asEmployment/ext:employerOrganization</b>		There is a known issue in the NEHTA Participation Data Specification [NE-HT2011v] for this logical data component's cardinality.  Furthermore the corresponding CDA elements ext:asEmployment and ext:employerOrganization do not allow the cardinality to be '0..*/multiple'. The cardinality <b>SHALL</b> be interpreted as '0..1' instead of '0..*'.  ext:asEmployment/@classCode="EMP"

<sup>2</sup> <http://www.hl7.org/oid/index.cfm?ref=footer>

NEHTA SCS Data Component	Data Component Definition	Card	CDA Schema Data Element	Vocab	Comments
Employment Detail > Employer Organisation > <b>Entity Identifier</b>	A number or code issued for the purpose of identifying a participant within a healthcare context.	1..*	ext:asEmployment/ext:employerOrganization/asOrganizationPartOf/wholeOrganization/<Entity Identifier>	The value of one Entity Identifier <b>SHALL</b> be an Australian HPI-O.	See common pattern: <a href="#">Entity Identifier</a> .
Employment Detail > Employer Organisation > <b>Organisation</b>	Any organisation of interest to, or involved in, the business of healthcare service provision.	1..1	n/a		Not mapped directly, encompassed implicitly in assignedAuthor/ext:asEmployment/employerOrganization.
Employment Detail > Employer Organisation > Organisation > <b>Organisation Name</b>	The name by which an organisation is known or called.	1..1	ext:asEmployment/ext:employerOrganization/asOrganizationPartOf/wholeOrganization/name		
Employment Detail > Employer Organisation > Organisation > <b>Department/Unit</b>	The name by which a department or unit within a larger organisation is known or called.	0..1	ext:asEmployment/ext:employerOrganization/name		
Employment Detail > Employer Organisation > Organisation > <b>Organisation Name Usage</b>	The classification that enables differentiation between recorded names for an organisation or service location.	0..1	ext:asEmployment/ext:employerOrganization/asOrganizationPartOf/wholeOrganization/name/@use	<a href="#">AS 4846-2006: Health Care Provider Organisation Name Usage</a>	
Employment Detail > <b>Employment Type</b>	The basis on which the person is employed by the employer organisation.	0..1	ext:asEmployment/ext:jobClassCode	NS	
Employment Detail > <b>Occupation</b>	A descriptor of the class of job based on similarities in the tasks undertaken.	0..*	ext:asEmployment/ext:jobCode	<a href="#">1220.0 - ANZSCO - Australian and New Zealand Standard Classification of Occupations, First Edition, Revision 1 [ABS2009]</a>	The corresponding CDA element ext:jobCode does not allow the cardinality to be '0..*/multiple'. The cardinality <b>SHALL</b> be interpreted as '0..1' instead of '0..*'.  
Employment Detail > <b>Position In Organisation</b>	A descriptor of the job or the job role based on the management hierarchy of the organisation.	0..1	ext:asEmployment/ext:code	NS	



## Example 8.12. Employment

<!-- This xml fragment is provided to demonstrate an example instance of each structured element in the CDA Mapping table. It is illustrative only. Logical model constraints on allowed combinations of child components are ignored in order to provide coverage of structured elements. This fragment cannot be treated as clinically valid. While the values in the fragment are conformant with the CDA Mapping table they are typically exaggerated to highlight the semantic meaning of the structured elements and may not be indicative of the expected values in a clinical document. While every effort has been taken to ensure that the examples are consistent with the message specification, where there are conflicts with the written message specification or schema, the specification or schema will take precedence. -->

```
<!-- Employment Details -->
<ext:asEmployment classCode="EMP">

  <!-- Position In Organisation -->
  <ext:code>
    <originalText>Chief Oncologist</originalText>
  </ext:code>

  <!-- Occupation -->
  <ext:jobCode code="253314" codeSystem="2.16.840.1.113883.13.62"
    codeSystemName="1220.0 - ANZSCO - Australian and New Zealand Standard Classification of Occupations, First Edition, Revision 1"
    displayName="Medical Oncologist"/>/>

  <!-- Employment Type -->
  <ext:jobClassCode code="FT" codeSystem="2.16.840.1.113883.5.1059" codeSystemName="HL7:EmployeeJobClass" displayName="full-time"/>

  <!-- Employer Organisation -->
  <ext:employerOrganization>
    <!-- Department/Unit -->
    <name>Oncology Ward</name>
    <asOrganizationPartOf>
      <wholeOrganization>

        <!-- Organisation Name -->
        <name use="ORGB">Acme Hospital</name>

        <!-- Entity Identifier -->
        <ext:asEntityIdentifier classCode="IDENT">
          <ext:id assigningAuthorityName="HPI-O" root="1.2.36.1.2001.1003.0.8003621566684455"/>
          <ext:assigningGeographicArea classCode="PLC">
            <ext:name>National Identifier</ext:name>
          </ext:assigningGeographicArea>
        </ext:asEntityIdentifier>

        <!-- Address -->
        <addr use="WP">
          <houseNumber>1</houseNumber>
          <streetName>Clinician</streetName>
          <streetNameType>St</streetNameType>
          <city>Nehtaville</city>
          <state>QLD</state>
          <postalCode>5555</postalCode>
          <additionalLocator>32568931</additionalLocator>
        </addr>

        <!-- Electronic Communication Detail -->
        <telecom value="tel:0499999999" use="H" />

      </wholeOrganization>
    </asOrganizationPartOf>
  </ext:employerOrganization>
```

</ext:asEmployment>



## 9 NEHTA CDA Extensions

As part of the CDA, standard extensions are allowed as follows:

Locally-defined markup may be used when local semantics have no corresponding representation in the CDA specification. CDA seeks to standardize the highest level of shared meaning while providing a clean and standard mechanism for tagging meaning that is not shared. In order to support local extensibility requirements, it is permitted to include additional XML elements and attributes that are not included in the CDA schema. These extensions should not change the meaning of any of the standard data items, and receivers must be able to safely ignore these elements. Document recipients must be able to faithfully render the CDA document while ignoring extensions.

Extensions may be included in the instance in a namespace other than the HL7v3 namespace, but must not be included within an element of type ED (e.g., <text> within <procedure>) since the contents of an ED datatype within the conformant document may be in a different namespace. Since all conformant content (outside of elements of type ED) is in the HL7 namespace, the sender can put any extension content into a foreign namespace (any namespace other than the HL7 namespace). Receiving systems must not report an error if such extensions are present. "HL7 Clinical Document Architecture, Release 2" [\[HL7CDAR2\]](#)

As such the following extensions have been defined where Australian concepts were not represented in CDA.

This section is provided for clarity only. Please see the relevant mappings section where these extensions have been used for actual mapping details.

### 9.1 ClinicalDocument.completionCode

Figure 9.1 CDA R-MIM Representation shows a subset of the CDA R-MIM containing those classes with the relevant NEHTA CDA extension represented.

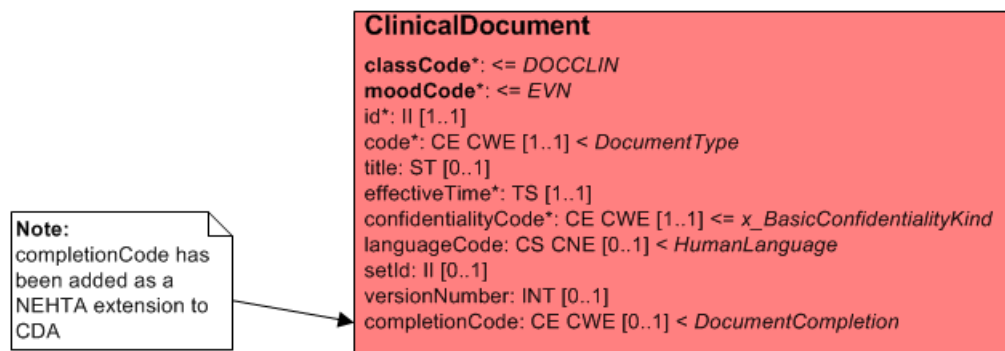

Figure 9.1. CDA R-MIM Representation

# 9.2 EntityIdentifier

Figure 9.2 CDA R-MIM Representation shows a subset of the CDA R-MIM containing those classes with the relevant NEHTA CDA extension represented.

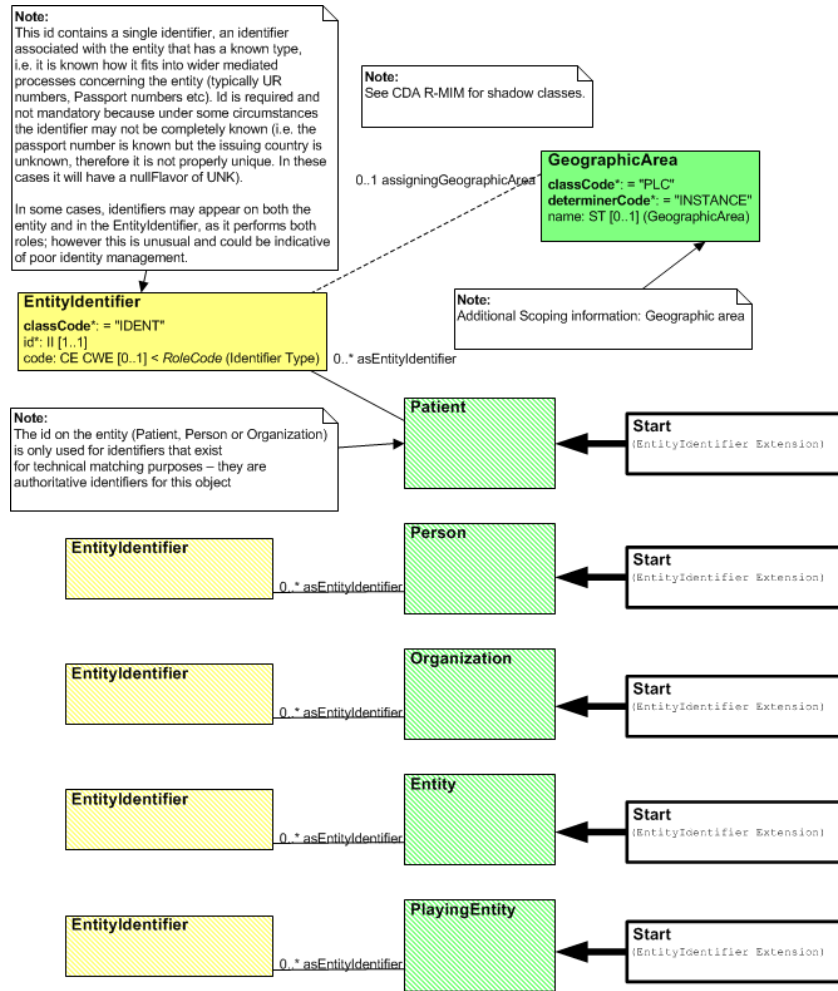

Figure 9.2. CDA R-MIM Representation

## 9.3 Entitlement

Figure 9.3 CDA R-MIM Representation shows a subset of the CDA R-MIM containing those classes with the relevant NEHTA CDA extension represented.

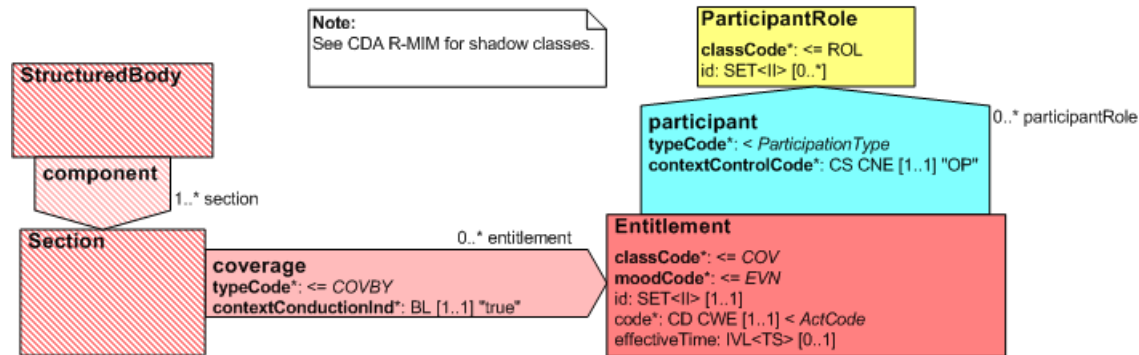
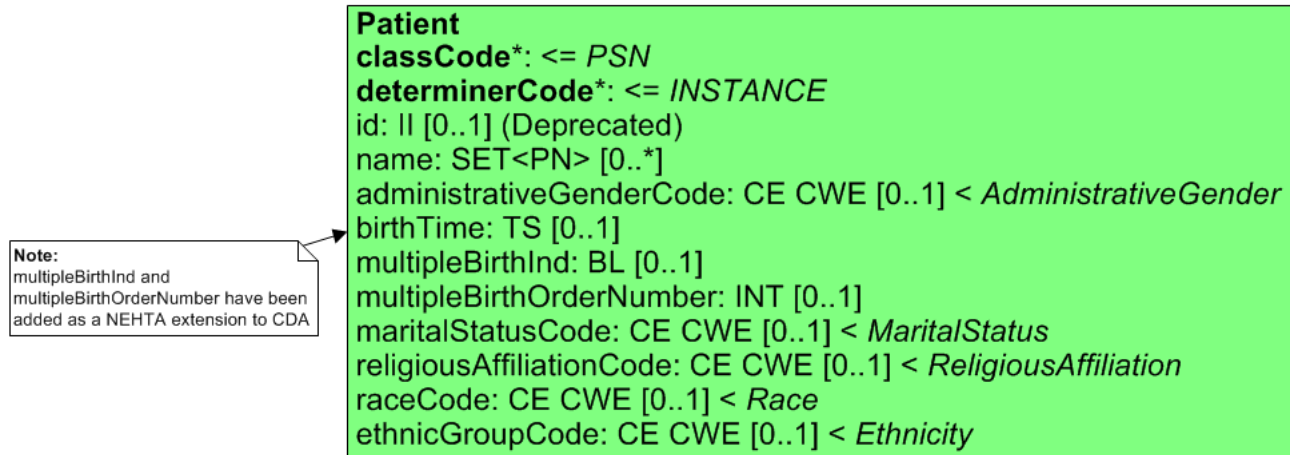

Figure 9.3. CDA R-MIM Representation

## 9.4 Multiple Birth

Figure 9.4 CDA R-MIM Representation shows a subset of the CDA R-MIM containing those classes with the relevant NEHTA CDA extension represented.



**Figure 9.4. CDA R-MIM Representation**

## 9.5 Administrative Gender Code

Figure 9.5 CDA R-MIM Representation shows a subset of the CDA R-MIM containing those classes with the relevant NEHTA CDA extension represented.

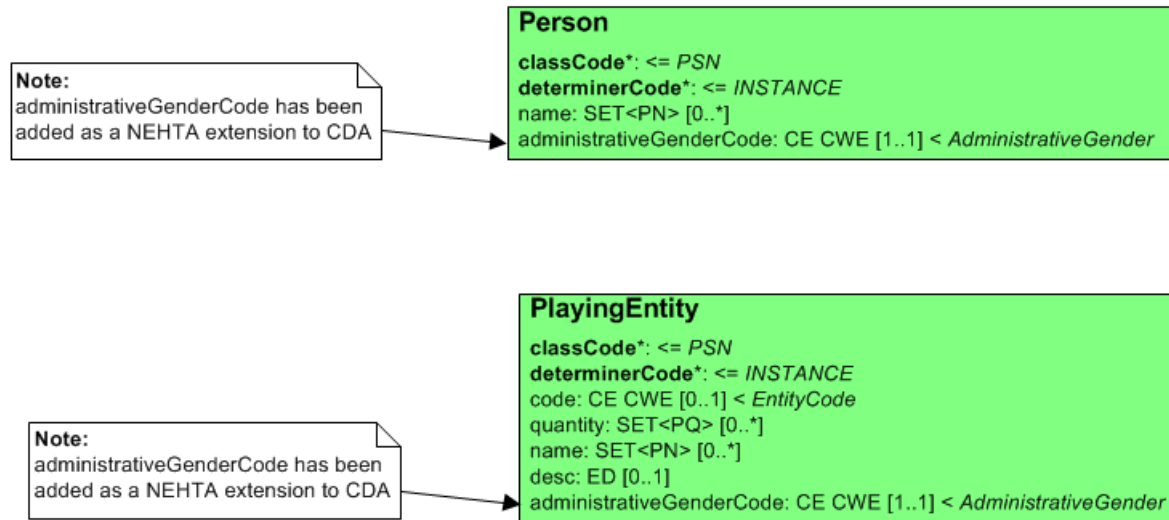

Figure 9.5. CDA R-MIM Representation



## 9.6 Birth Time

Figure 9.6 CDA R-MIM Representation shows a subset of the CDA R-MIM containing those classes with the relevant NEHTA CDA extension represented.

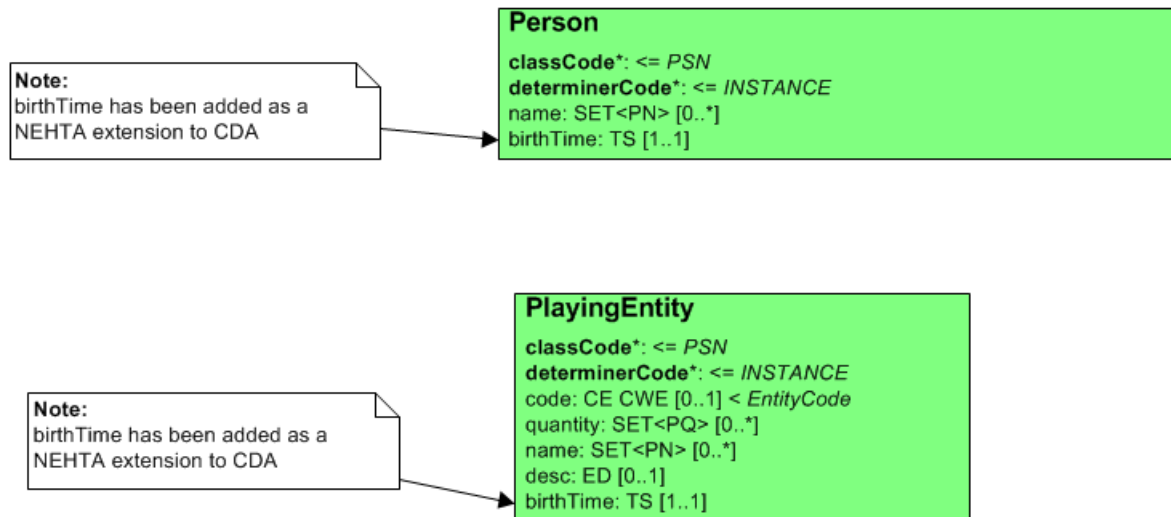

Figure 9.6. CDA R-MIM Representation

## 9.7 Deceased Time

Figure 9.7 CDA R-MIM Representation shows a subset of the CDA R-MIM containing those classes with the relevant NEHTA CDA extension represented.

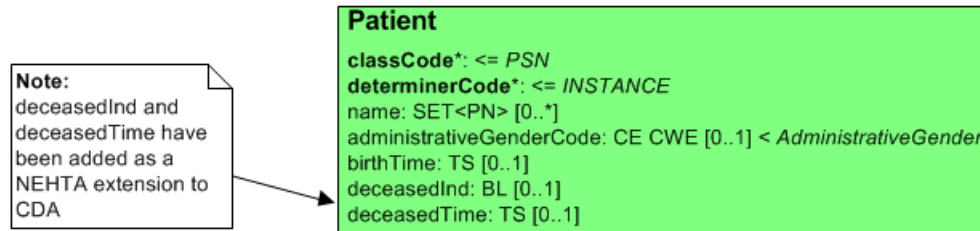

Figure 9.7. CDA R-MIM Representation

# 9.8 Employment

Figure 9.8 CDA R-MIM Representation shows a subset of the CDA R-MIM containing those classes with the relevant NEHTA CDA extension represented.

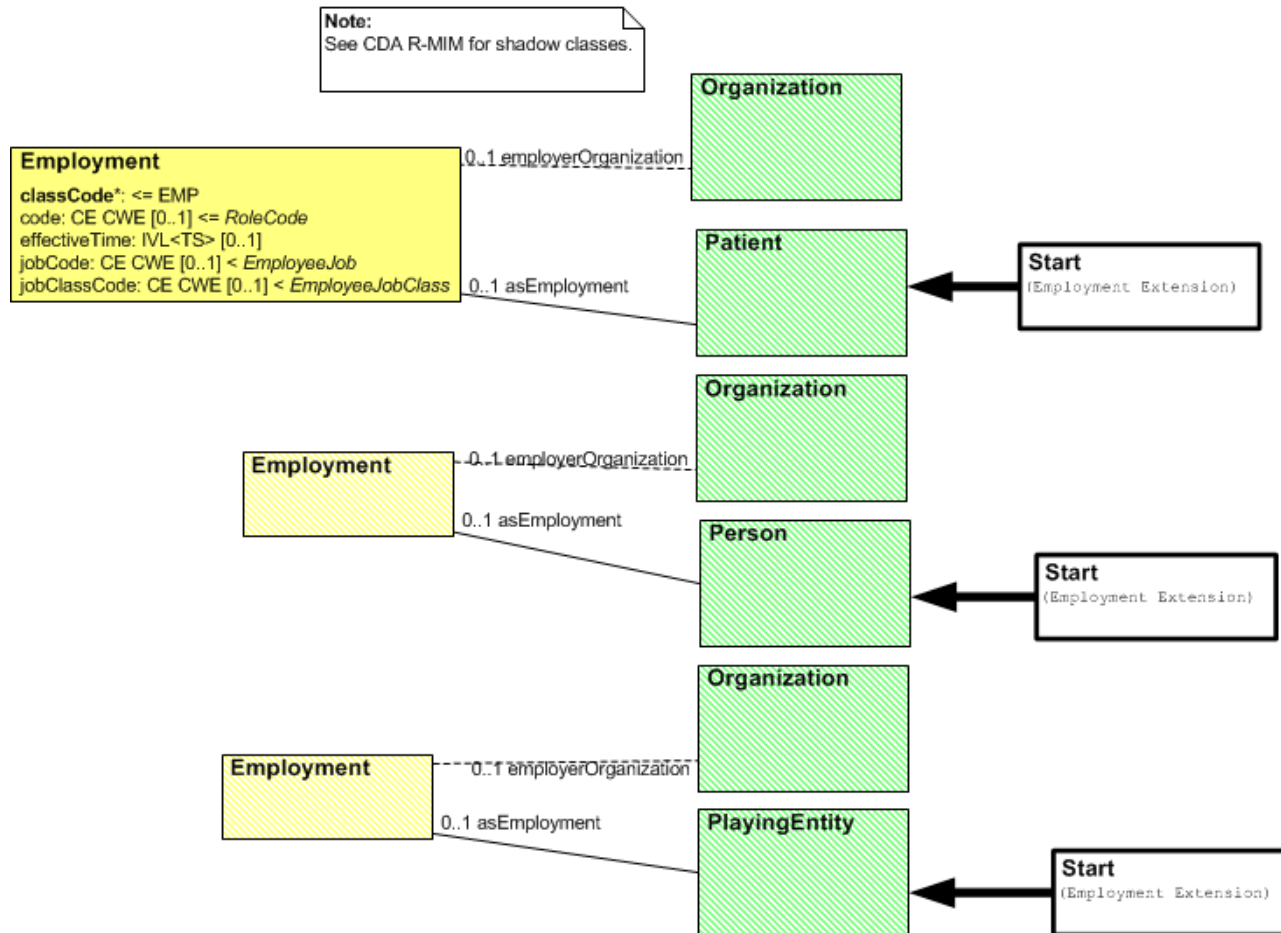

Figure 9.8. CDA R-MIM Representation

## 9.9 Qualifications

Figure 9.9 CDA R-MIM Representation shows a subset of the CDA R-MIM containing those classes with the relevant NEHTA CDA extension represented.

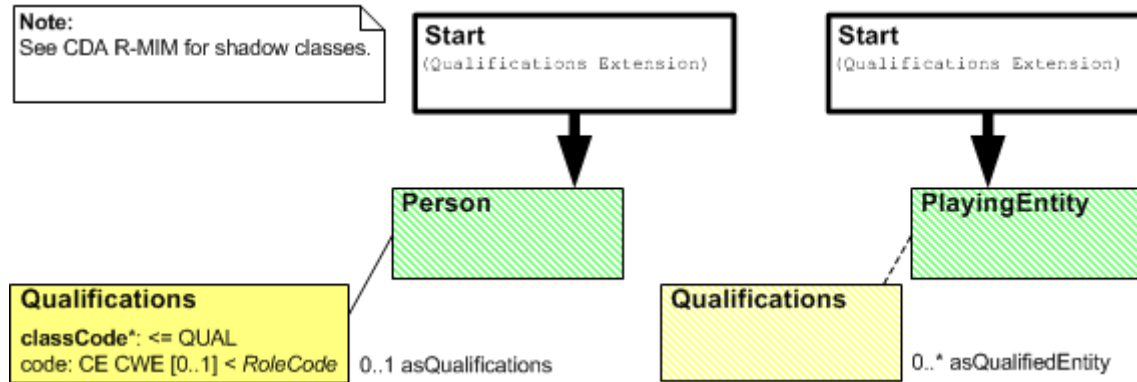

Figure 9.9. CDA R-MIM Representation

# 9.10 Container

Figure 9.10 CDA R-MIM Representation shows a subset of the CDA R-MIM containing those classes with the relevant NEHTA CDA extension represented.

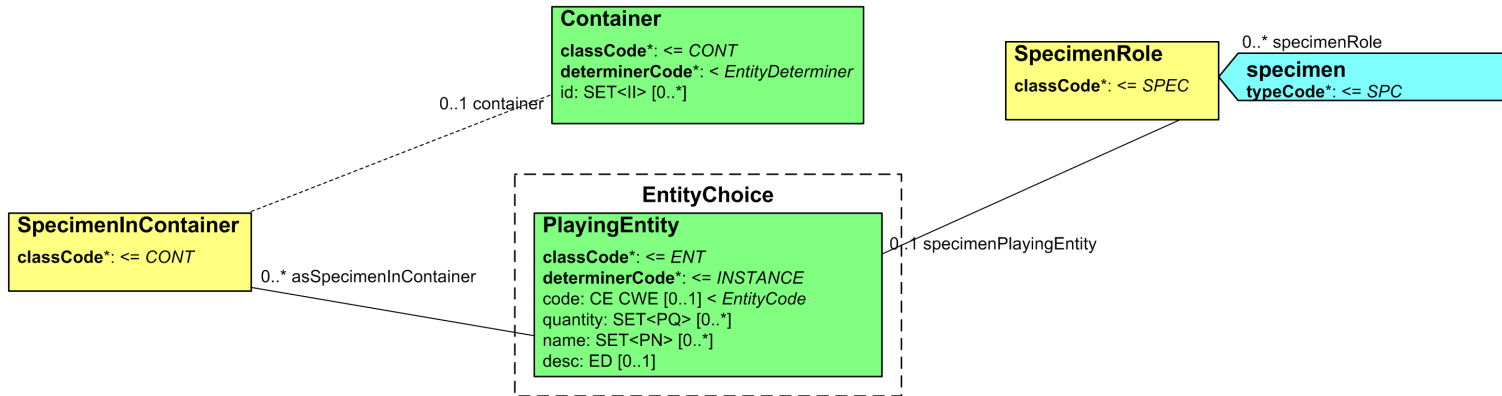

Figure 9.10. CDA R-MIM Representation

# 10 Vocabularies and Code Sets

This product includes all or a portion of the HL7 Vocabulary, or is derived from the HL7 Vocabulary, subject to a license from Health Level Seven International. Your use of the HL7 Vocabulary also is subject to this license, a copy of which is accessible through the following link: <http://www.hl7.org/permalink/?VocabTables>. The current complete HL7 Vocabulary is also available through this link. The HL7 Vocabulary is copyright © 1989-2010, Health Level Seven International. All rights reserved. THE HL7 VOCABULARY IS PROVIDED "AS IS." ANY EXPRESS OR IMPLIED WARRANTIES ARE DISCLAIMED, INCLUDING, BUT NOT LIMITED TO, THE IMPLIED WARRANTIES OF MERCHANTABILITY AND FITNESS FOR A PARTICULAR PURPOSE.

## Example 10.1. All values

```
<code  
  code="103.16044.4.1.1"  
  codeSystem="1.2.36.1.2001.1001"  
  codeSystemName="NCTIS_CODE_SYSTEM_NAME;"  
  displayName="Additional Comments" />
```

## Example 10.2. One value

```
<name use="I">  
  {name}  
</name>
```

## 10.1 HL7: TelecommunicationAddressUse

Code	Value
H	Home
HP	Primary Home
HV	Vacation Home
WP	Workplace
AS	Answering Service
EC	Emergency Contact
MC	Mobile Contact

Code	Value
PG	Pager

## 10.2 AS 5017-2006 Health Care Client Identifier Sex

displayName	code	codeSystemName	codeSystem
Male	M	AS 5017-2006 Health Care Client Identifier Sex	2.16.840.1.113883.13.68
Female	F	AS 5017-2006 Health Care Client Identifier Sex	2.16.840.1.113883.13.68
Intersex or Indeterminate	I	AS 5017-2006 Health Care Client Identifier Sex	2.16.840.1.113883.13.68
Not Stated/Inadequately Described	N	AS 5017-2006 Health Care Client Identifier Sex	2.16.840.1.113883.13.68



## 10.3 AS 5017-2006: Health Care Client Name Usage

Code Set AS 5017-2006 mapped to HL7 Entity Name Use Code

When referencing the following vocabulary tables, if one column in the code set table is bolded, use the code in that column; otherwise use the values in all columns.



### Note

CDA Release 2 uses HL7 Data Types Release 1. For some of the AS 5017-2006 values, there are no satisfactory equivalents in the HL7 Entity Name Use R1 code set. In these cases (marked R2), an HL7 Entity Name Use R2 code has been used.



### Note

In cases (marked EXT) where there are no suitable HL7 codes, extension codes have been created.

AS 5017-2006 Code	AS 5017-2006 Alternative Code	AS 5017-2006 Descriptor	HL7 Entity Name Use Code	HL7 Entity Name Use Name	HL7 Name Use Definition
1	L	Registered Name (Legal Name)	<b>L</b>	(R1) Legal	(R1) Known as/conventional/the one you use.
2	R	Reporting Name	<b>C</b>	(R1) License	(R1) As recorded on a license, record, certificate, etc. (only if different from legal name).
3	N	Newborn Name	<b>NB</b>	(EXT)	(EXT)
4	B	Professional or Business Name	<b>A</b>	(R1) Artist/Stage	(R1) Includes writer's pseudonym, stage name, etc.
5	M	Maiden Name (Name at birth)	<b>M</b>	(R2) Maiden Name	A name used prior to marriage.
8	O	Other Name (Alias)	<b>P</b>	(R1) Pseudonym	(R1) A self-asserted name that the person is using or has used.

## 10.4 AS 4846-2006: Health Care Provider Organisation Name Usage

Code Set AS 5017-2006 Organisation Name Usage mapped to HL7 Name Use Code

When referencing the following vocabulary tables, if one column in the code set table is bolded, use the code in that column; otherwise use the values in all columns.



### Note

There are no suitable HL7 codes, so extension codes have been created.

AS 4846-2006 Code	AS 4846-2006 Alternative Code	AS 4846-2006 Descriptor	HL7 Name Use Code	HL7 Name Use Name	HL7 Name Use Definition
1	U	Organizational unit/section/division name	<b>ORGU</b>	(EXT)	(EXT)
2	S	Service location name	<b>ORGS</b>	(EXT)	(EXT)
3	B	Business name	<b>ORGB</b>	(EXT)	(EXT)
4	L	Locally used name	<b>ORGL</b>	(EXT)	(EXT)
5	A	Abbreviated name	<b>ORGA</b>	(EXT)	(EXT)
6	E	Enterprise name	<b>ORGE</b>	(EXT)	(EXT)
8	X	Other	<b>ORGX</b>	(EXT)	(EXT)
9	Y	Unknown	<b>ORGY</b>	(EXT)	(EXT)

## 10.5 AS 5017-2006: Health Care Client Source of Death Notification

displayName	code	codeSystemName	codeSystem
Official death certificate or death register	D	AS 5017-2006 Health Care Client Source of Death Notification	2.16.840.1.113883.13.64
Health Care Provider	H	AS 5017-2006 Health Care Client Source of Death Notification	2.16.840.1.113883.13.64
Relative	R	AS 5017-2006 Health Care Client Source of Death Notification	2.16.840.1.113883.13.64
Other	O	AS 5017-2006 Health Care Client Source of Death Notification	2.16.840.1.113883.13.64
Unknown	U	AS 5017-2006 Health Care Client Source of Death Notification	2.16.840.1.113883.13.64

## 10.6 AS 5017-2006: Health Care Client Identifier Address Purpose

AS 5017-2006 mapped to HL7 AddressUse Code

When referencing the following vocabulary tables, if one column in the code set table is bolded, use the code in that column; otherwise use the values in all columns.

AS 5017-2006 Code	AS 5017-2006 Alternative Code	AS 5017-2006 Descriptor	HL7 AddressUse Code	HL7 AddressUse Name	HL7 AddressUse Definition
1	B	Business	<b>WP</b>	Work Place	An office address. First choice for business related contacts during business hours.
2	M	Mailing or Postal	<b>PST</b>	Postal Address	Used to send mail.
3	T	Temporary Accommodation (individual provider only)	<b>TMP</b>	Temporary Address	A temporary address, may be good for visit or mailing.
4	R	Residential (permanent) (individual provider only)	<b>H</b>	Home Address	A communication address at a home.
9	U	Not Stated/Unknown/Inadequately Described	<b>In this case simply omit the Address Use Code</b>		

## 10.7 AS 5017-2006: Health Care Client Identifier Geographic Area

displayName	code	codeSystemName	codeSystem
Local Client (Unit Record) Identifier	L	AS 5017-2006 Health Care Client Identifier Geographic Area	2.16.840.1.113883.13.63
Area/Region/District Identifier	A	AS 5017-2006 Health Care Client Identifier Geographic Area	2.16.840.1.113883.13.63
State or Territory Identifier	S	AS 5017-2006 Health Care Client Identifier Geographic Area	2.16.840.1.113883.13.63
National Identifier	N	AS 5017-2006 Health Care Client Identifier Geographic Area	2.16.840.1.113883.13.63

## 10.8 AS 5017-2006: Health Care Client Electronic Communication Medium

When referencing the following vocabulary tables, if one column in the code set table is bolded, use the code in that column; otherwise use the values in all columns.

AS 5017-2006 Code	AS 5017-2006 Descriptor	AS 5017-2006 Alternative Code	HL7 URLScheme Code	HL7 URLScheme Name	HL7 URLScheme Definition
1	Telephone (excluding mobile telephone)	T	<b>tel</b>	Telephone	A voice telephone number.
2	Mobile (cellular) telephone  NOTE: Mobile will also need a Telecommunication-Address Use code of MC (Mobile Contact) (see <a href="#">HL7: TelecommunicationAddressUse</a> )	M	<b>tel</b>	Telephone	A voice telephone number.
3	Facsimile machine	F	<b>fax</b>	Fax	A telephone number served by a fax device.
4	Pager  NOTE: Pager will also need a TelecommunicationAddress Use code of PG (Pager) (see <a href="#">HL7: TelecommunicationAddressUse</a> )	P	<b>tel</b>	Telephone	A voice telephone number
5	Email	E	<b>mailto</b>	Mailto	Electronic mail address.

AS 5017-2006 Code	AS 5017-2006 Descriptor	AS 5017-2006 Alternative Code	HL7 URLScheme Code	HL7 URLScheme Name	HL7 URLScheme Definition
6	URL	U	Use the most appropriate code from the list below:		
			<b>file</b>	File	Host-specific local file names. Note that the file scheme works only for local files. There is little use for exchanging local file names between systems, since the receiving system likely will not be able to access the file.
			<b>ftp</b>	FTP	The File Transfer Protocol (FTP).
			<b>http</b>	HTTP	Hypertext Transfer Protocol.
			<b>mlp</b>	MLLP	The traditional HL7 Minimal Lower Layer Protocol. The URL has the form of a common IP URL e.g., mllp://<host>:<port>/ with <host> being the IP address or DNS hostname and <port> being a port number on which the MLLP protocol is served.
			<b>modem</b>	Modem	A telephone number served by a modem device.
			<b>nfs</b>	NFS	Network File System protocol. Some sites use NFS servers to share data files.
			<b>telnet</b>	Telnet	Reference to interactive sessions. Some sites, (e.g., laboratories) have TTY based remote query sessions that can be accessed through telnet.

## 10.9 AS 5017-2006: Health Care Client Electronic Communication Usage Code

AS 5017-2006 mapped to HL7 TelecommunicationAddressUse (HL7 TAU) Code

When referencing the following vocabulary tables, if one column in the code set table is bolded, use the code in that column; otherwise use the values in all columns.

Code	Descriptor	Alternative Code	HL7 TAU Code	HL7 TAU Name	HL7 TAU Description
1	Business	B	<b>WP</b>	Work place	An office address. First choice for business related contacts during business hours.
2	Personal	P	<b>H</b>	Home address	A communication address at a home, attempted contacts for business purposes might intrude privacy and chances are one will contact family or other household members instead of the person one wishes to call. Typically used with urgent cases, or if no other contacts are available.
3	Both business and personal use	A	<b>WP H</b>	Both Work place and Home address	



## 10.10 AS 5017-2006 Australian State/Territory Identifier - Postal

Code	Descriptor
NSW	New South Wales
VIC	Victoria
QLD	Queensland
SA	South Australia
WA	Western Australia
TAS	Tasmania
NT	Northern Territory
ACT	Australian Capital Territory
U	Unknown

## 10.11 AS 5017-2006 Health Care Client Identifier Date Accuracy Indicator

The data elements that use this value set consist of a combination of three codes, each of which denotes the accuracy of one date component:

A – The referred date component is accurately known.

E – The referred date component is an estimate.

U – The referred date component is unknown.

The data elements that use this value set contain positional fields (DMY).

Field 1 (D) – refers to the accuracy of the day component.

Field 2 (M) – refers to the accuracy of the month component.

Field 3 (Y) – refers to the accuracy of the year component.



### Note

The order of the date components in the HL7 date and time datatypes (YYYYMMDD) is the reverse of that specified above.

The possible combinations are as follows:

code	descriptor
AAA	Accurate date
AAE	Accurate day and month, estimated year
AEA	Accurate day, estimated month, accurate year
AAU	Accurate day and month, unknown year
AUA	Accurate day, unknown month, accurate year
AEE	Accurate day, estimated month and year
AUU	Accurate day, unknown month and year

code	descriptor
AEU	Accurate day, estimated month, unknown year
AUE	Accurate day, unknown month
EEE	Estimated date
EEA	Estimated day and month, accurate year
EAE	Estimated day, accurate month
EEU	Estimated day and month, unknown year
EUE	Estimated day, unknown month, estimated year
EAA	Estimated day, accurate month and year
EUU	Estimated day, unknown month and year
EAU	Estimated day, accurate month, unknown year
EUA	Estimated day, unknown month, accurate year
UUU	Unknown date
UUA	Unknown day and month, accurate year
UAU	Unknown day, accurate month, unknown year
UUE	Unknown day and month, estimated year
UEU	Unknown day, estimated month, unknown year
UAA	Unknown day, accurate month and year
UEE	Unknown day, estimated month and year
UAE	Unknown day, accurate month, estimated year
UEA	Unknown day, estimated month, accurate year

## 10.12 NCTIS: Admin Codes - Document Status

displayName	code	codeSystemName	codeSystem
Interim	I	NCTIS Document Status Values	1.2.36.1.2001.1001.101.104.20104
Final	F	NCTIS Document Status Values	1.2.36.1.2001.1001.101.104.20104
Withdrawn	W	NCTIS Document Status Values	1.2.36.1.2001.1001.101.104.20104

## 10.13 NCTIS: Admin Codes - Entitlement Type

displayName	code	codeSystemName	codeSystem
Medicare Benefits	1	NCTIS Entitlement Type Values	1.2.36.1.2001.1001.101.104.16047
Pensioner Concession	2	NCTIS Entitlement Type Values	1.2.36.1.2001.1001.101.104.16047
Commonwealth Seniors Health Concession	3	NCTIS Entitlement Type Values	1.2.36.1.2001.1001.101.104.16047
Health Care Concession	4	NCTIS Entitlement Type Values	1.2.36.1.2001.1001.101.104.16047
Repatriation Health Gold Benefits	5	NCTIS Entitlement Type Values	1.2.36.1.2001.1001.101.104.16047
Repatriation Health White Benefits	6	NCTIS Entitlement Type Values	1.2.36.1.2001.1001.101.104.16047
Repatriation Health Orange Benefits	7	NCTIS Entitlement Type Values	1.2.36.1.2001.1001.101.104.16047
Safety Net Concession	8	NCTIS Entitlement Type Values	1.2.36.1.2001.1001.101.104.16047
Safety Net Entitlement	9	NCTIS Entitlement Type Values	1.2.36.1.2001.1001.101.104.16047
Medicare Prescriber Number	10	NCTIS Entitlement Type Values	1.2.36.1.2001.1001.101.104.16047
Medicare Pharmacy Approval Number	11	NCTIS Entitlement Type Values	1.2.36.1.2001.1001.101.104.16047

## 10.14 HL7 v3 CDA: Act.moodCode

Code	Value	Definition
<b>EVN</b>	Event	The entry defines an actual occurrence of an event.
<b>INT</b>	Intent	The entry is intended or planned.
<b>APT</b>	Appointment	The entry is planned for a specific time and place.
<b>ARQ</b>	Appointment Re- quest	The entry is a request for the booking of an appointment.
<b>PRMS</b>	Promise	A commitment to perform the stated entry.
<b>PRP</b>	Proposal	A proposal that the stated entry be performed.
<b>RQO</b>	Request	A request or order to perform the stated entry.
<b>DEF</b>	Definition	The entry defines a service (master).

## 10.15 HL7 v3 CDA: RelatedDocument.typeCode

Code	Value	Definition
RPLC	Replace	The current document is a replacement of the ParentDocument.
XFRM	Transform	The current document is a transformation of the ParentDocument.

## 10.16 METeOR 291036: Indigenous Status

displayName	code	codeSystemName	codeSystem
Aboriginal but not Torres Strait Islander origin	1	METeOR Indigenous Status	2.16.840.1.113883.3.879.291036
Torres Strait Islander but not Aboriginal origin	2	METeOR Indigenous Status	2.16.840.1.113883.3.879.291036
Both Aboriginal and Torres Strait Islander origin	3	METeOR Indigenous Status	2.16.840.1.113883.3.879.291036
Neither Aboriginal nor Torres Strait Islander origin	4	METeOR Indigenous Status	2.16.840.1.113883.3.879.291036
Not stated/inadequately described	9	METeOR Indigenous Status	2.16.840.1.113883.3.879.291036



## 10.17 CodeSystem OIDs



### Note

The entries in the codeSystem (Name) column enable identification of the codeSystem OID to be used, but may not be the proper name of that codeSystem, i.e. the value of the codeSystemName attribute. The value of codeSystemName **SHOULD** be the name associated with the OID in the [HL7 OID Registry](http://www.hl7.org/oid/index.cfm?ref=footer)<sup>1</sup>.

codeSystem (OID)	codeSystem (Name)
1.2.36.1.2001.1001.101	NCTIS Data Components
2.16.840.1.113883.13.62	1220.0 - ANZSCO - Australian and New Zealand Standard Classification of Occupations, First Edition, Revision 1
2.16.840.1.113883.13.65	AIHW Mode of Separation
2.16.840.1.113883.6.96	SNOMED CT
2.16.840.1.113883.6.96	SNOMED CT-AU
1.2.36.1.2001.1004.100	Australian Medicines Terminology (AMT) v2
2.16.840.1.113883.6.96	Australian Medicines Terminology (AMT) v3
2.16.840.1.113883.6.1	LOINC

<sup>1</sup> <http://www.hl7.org/oid/index.cfm?ref=footer>

## 10.18 HL7 V3: ObservationInterpretationNormality

displayName	code	codeSystemName	codeSystem
Abnormal	A	HL7 ObservationInterpretationNormality	2.16.840.1.113883.5.83
Abnormal alert	AA	HL7 ObservationInterpretationNormality	2.16.840.1.113883.5.83
High alert	HH	HL7 ObservationInterpretationNormality	2.16.840.1.113883.5.83
Low alert	LL	HL7 ObservationInterpretationNormality	2.16.840.1.113883.5.83
High	H	HL7 ObservationInterpretationNormality	2.16.840.1.113883.5.83
Low	L	HL7 ObservationInterpretationNormality	2.16.840.1.113883.5.83
Normal	N	HL7 ObservationInterpretationNormality	2.16.840.1.113883.5.83

## 10.19 HL7: Diagnostic Service Section ID

displayName	code	codeSystemName	codeSystem
Audiology	AU	HL7 Diagnostic service section ID	2.16.840.1.113883.12.74
Bedside ICU Monitoring	ICU	HL7 Diagnostic service section ID	2.16.840.1.113883.12.74
Blood Bank	BLB	HL7 Diagnostic service section ID	2.16.840.1.113883.12.74
Blood Gases	BG	HL7 Diagnostic service section ID	2.16.840.1.113883.12.74
Cardiac Catheterization	CTH	HL7 Diagnostic service section ID	2.16.840.1.113883.12.74
Cardiac Ultrasound	CUS	HL7 Diagnostic service section ID	2.16.840.1.113883.12.74
CAT Scan	CT	HL7 Diagnostic service section ID	2.16.840.1.113883.12.74
Chemistry	CH	HL7 Diagnostic service section ID	2.16.840.1.113883.12.74
Cineradiograph	XRC	HL7 Diagnostic service section ID	2.16.840.1.113883.12.74
Cytopathology	CP	HL7 Diagnostic service section ID	2.16.840.1.113883.12.74
Electrocardiac (e.g., EKG, EEC, Holter)	EC	HL7 Diagnostic service section ID	2.16.840.1.113883.12.74
Electroneuro (EEG, EMG,EP,PSG)	EN	HL7 Diagnostic service section ID	2.16.840.1.113883.12.74
Hematology	HM	HL7 Diagnostic service section ID	2.16.840.1.113883.12.74
Immunology	IMM	HL7 Diagnostic service section ID	2.16.840.1.113883.12.74
Laboratory	LAB	HL7 Diagnostic service section ID	2.16.840.1.113883.12.74
Microbiology	MB	HL7 Diagnostic service section ID	2.16.840.1.113883.12.74
Mycobacteriology	MCB	HL7 Diagnostic service section ID	2.16.840.1.113883.12.74
Mycology	MYC	HL7 Diagnostic service section ID	2.16.840.1.113883.12.74
Nuclear Magnetic Resonance	NMR	HL7 Diagnostic service section ID	2.16.840.1.113883.12.74
Nuclear Medicine Scan	NMS	HL7 Diagnostic service section ID	2.16.840.1.113883.12.74
Nursing Service Measures	NRS	HL7 Diagnostic service section ID	2.16.840.1.113883.12.74
OB Ultrasound	OUS	HL7 Diagnostic service section ID	2.16.840.1.113883.12.74
Occupational Therapy	OT	HL7 Diagnostic service section ID	2.16.840.1.113883.12.74

<b>displayName</b>	<b>code</b>	<b>codeSystemName</b>	<b>codeSystem</b>
Other	OTH	HL7 Diagnostic service section ID	2.16.840.1.113883.12.74
Outside Lab	OSL	HL7 Diagnostic service section ID	2.16.840.1.113883.12.74
Pharmacy	PHR	HL7 Diagnostic service section ID	2.16.840.1.113883.12.74
Physical Therapy	PT	HL7 Diagnostic service section ID	2.16.840.1.113883.12.74
Physician (Hx. Dx, admission note, etc.)	PHY	HL7 Diagnostic service section ID	2.16.840.1.113883.12.74
Pulmonary Function	PF	HL7 Diagnostic service section ID	2.16.840.1.113883.12.74
Radiation Therapy	RT	HL7 Diagnostic service section ID	2.16.840.1.113883.12.74
Radiograph	RX	HL7 Diagnostic service section ID	2.16.840.1.113883.12.74
Radiology	RAD	HL7 Diagnostic service section ID	2.16.840.1.113883.12.74
Radiology Ultrasound	RUS	HL7 Diagnostic service section ID	2.16.840.1.113883.12.74
Respiratory Care (therapy)	RC	HL7 Diagnostic service section ID	2.16.840.1.113883.12.74
Serology	SR	HL7 Diagnostic service section ID	2.16.840.1.113883.12.74
Surgical Pathology	SP	HL7 Diagnostic service section ID	2.16.840.1.113883.12.74
Toxicology	TX	HL7 Diagnostic service section ID	2.16.840.1.113883.12.74
Vascular Ultrasound	VUS	HL7 Diagnostic service section ID	2.16.840.1.113883.12.74
Virology	VR	HL7 Diagnostic service section ID	2.16.840.1.113883.12.74

## 10.20 HL7: Result Status

HL7 Table 0123 - Result Status

displayName	code	codeSystemName	codeSystem
Correction to results	C	HL7 Result Status	2.16.840.1.113883.12.123
Final results; results stored and verified. Can only be changed with a corrected result.	F	HL7 Result Status	2.16.840.1.113883.12.123
No results available; specimen received, procedure incomplete	I	HL7 Result Status	2.16.840.1.113883.12.123
Order received; specimen not yet received	O	HL7 Result Status	2.16.840.1.113883.12.123
Preliminary: A verified early result is available, final results not yet obtained	P	HL7 Result Status	2.16.840.1.113883.12.123
Results stored; not yet verified	R	HL7 Result Status	2.16.840.1.113883.12.123
No results available; procedure scheduled, but not done	S	HL7 Result Status	2.16.840.1.113883.12.123
Some, but not all, results available	A	HL7 Result Status	2.16.840.1.113883.12.123
No results available; Order canceled	X	HL7 Result Status	2.16.840.1.113883.12.123
No order on record for this test. (Used only on queries)	Y	HL7 Result Status	2.16.840.1.113883.12.123
No record of this patient. (Used only on queries)	Z	HL7 Result Status	2.16.840.1.113883.12.123

# Appendix A. CDA Narratives

CDA requires that each section in its body include a narrative block, containing a clinically complete version of the section's encoded content using custom hypertext markup defined by HL7. The narrative is the human-readable and attestable part of a CDA document, and **SHALL** stand alone as an accurate representation of the content of the document without any need to consult entries in the body.

There is no canonical markup for specific CDA components, but some conformance points apply:

- The narrative block **SHALL** be encapsulated within the text component of the CDA section.
- The narrative contents **SHALL** conform to the requirements specified in the CDA Rendering Specification.
  - In accordance with the requirement to completely represent section contents, values of codedText or codeableText data elements defined in the SCS **SHALL** include an originalText or a displayName component (or both). Where available, the originalText **SHOULD** be found in the narrative, otherwise the displayName **SHOULD** be found in the narrative.
- The narrative contents **SHALL** completely and accurately represent the clinical information encoded in the section. Content **SHALL NOT** be omitted from the narrative.
- The narrative **SHALL** conform to the content requirements of the CDA specification [[HL7CDAR2](#)] and the XML Schema.

Clinical judgement is required to determine the appropriate presentation for narrative. NEHTA may release additional guidance in this regard. The examples provided in sections of this document offer some guidance for narrative block markup and may be easily adapted as boilerplate markup.

DRAFT

# Reference List

- [ABS2008] Australian Bureau of Statistics, May 2008, *Standard Australian Classification of Countries (SACC) Cat. No. 1269*, accessed 15 March 2010.  
<http://www.abs.gov.au/ausstats/abs@.nsf/mf/1269.0>
- [ABS2009] Australian Bureau of Statistics, 25 June 2009, *1220.0 - ANZSCO - Australian and New Zealand Standard Classification of Occupations, First Edition, Revision 1*, accessed 28 August 2013.  
<http://www.abs.gov.au/AUSSTATS/abs@.nsf/allprimarymainfeatures/-E8A05691E35F4376CA257B9500138A52?opendocument>
- [AIHW2005] Australian Institute of Health and Welfare, March 2005, *AIHW Mode of Separation*, accessed 15 March 2010.  
<http://meteor.aihw.gov.au/content/index.phtml/itemId/270094>
- [HL7CDAR2] Health Level Seven, Inc., January 2010, *HL7 Clinical Document Architecture, Release 2*, accessed 12 November 2015.  
[http://www.hl7.org/implement/standards/product\\_brief.cfm?product\\_id=7](http://www.hl7.org/implement/standards/product_brief.cfm?product_id=7)
- [HL7RIM] Health Level Seven, Inc., January 2010, *HL7 Version 3 Standard – Reference Information Model*, accessed 13 March 2015.  
[http://www.hl7.org/implement/standards/product\\_brief.cfm?product\\_id=77](http://www.hl7.org/implement/standards/product_brief.cfm?product_id=77)
- [HL7V3] Health Level Seven, Inc., January 2010, *HL7 Version 3 Standard*, accessed 13 March 2015.  
[http://www.hl7.org/implement/standards/product\\_brief.cfm?product\\_id=186](http://www.hl7.org/implement/standards/product_brief.cfm?product_id=186)
- [HL7V3DT] Health Level Seven, Inc., January 2010, *HL7 V3 RIM, Data types and Vocabulary*, accessed 26 August 2014.  
<http://www.hl7.org/memonly/downloads/v3edition.cfm>
- [IHTS2010] International Health Terminology Standards Development Organisation, January 2010, *SNOMED CT*, accessed 15 March 2010.  
<http://www.ihtsdo.org/snomed-ct>
- [INFO2009] Canada Health Infoway, *CDA Validation Tools: infoway\_release\_2\_2X\_18.zip*, accessed 18 November 2009.  
<http://www.hl7.org/memonly/downloads/v3edition.cfm>
- [ISO2004a] International Organization for Standardization, 2004, *ISO 8601:2004 - Data elements and interchange formats - Information interchange - Representation of dates and times*, Edition 3 (Monolingual), accessed 09 November 2009.  
[http://www.iso.org/iso/iso\\_catalogue/catalogue\\_tc/catalogue\\_detail.htm?csnumber=40874](http://www.iso.org/iso/iso_catalogue/catalogue_tc/catalogue_detail.htm?csnumber=40874)
- [ISO2008a] International Organization for Standardization, 2008, *ISO 21090:2008 – Health Informatics – Harmonized data types for information interchange*, Edition 1 (Monolingual), accessed 09 November 2009.  
[http://www.iso.org/iso/iso\\_catalogue/catalogue\\_tc/catalogue\\_detail.htm?csnumber=35646](http://www.iso.org/iso/iso_catalogue/catalogue_tc/catalogue_detail.htm?csnumber=35646)
- [NEHT2005a] National E-Health Transition Authority, 25 May 2005, *NEHTA Acronyms, Abbreviations & Glossary of Terms*, Version 1.2, accessed 10 July 2015.  
[https://www.nehta.gov.au/component/docman/doc\\_download/8-clinical-information-glossary-v1-2?Itemid=](https://www.nehta.gov.au/component/docman/doc_download/8-clinical-information-glossary-v1-2?Itemid=)
- [NEHT2007b] National E-Health Transition Authority, 17 August 2007, *Interoperability Framework*, Version 2.0, accessed 24 June 2015.  
<http://www.nehta.gov.au/implementation-resources/ehealth-foundations/EP-1144-2007/NEHTA-1146-2007>
- [NEHT2010c] National E-Health Transition Authority, September 2010, *Data Types in NEHTA Specifications: A Profile of the ISO 21090 Specification*, Version 1.0, accessed 20 July 2014.  
<https://www.nehta.gov.au/implementation-resources/clinical-documents/EP-1135-2010/NEHTA-1136-2010>
- [NEHT2011v] National E-Health Transition Authority, 20 July 2011, *Participation Data Specification*, Version 3.2, accessed 20 Jul 2014.  
<https://www.nehta.gov.au/implementation-resources/clinical-documents/EP-1224-2011/NEHTA-0794-2011>



- [NEHT2012s] National E-Health Transition Authority, 07 March 2012, *CDA Rendering Specification*, Version 1.0.  
<http://www.nehta.gov.au/implementation-resources/clinical-documents/EP-1094-2011/NEHTA-1199-2012>
- [NEHT2014ag] National E-Health Transition Authority, 8 July 2014, *Australian Medicines Terminology v3 Model - Editorial Rules v2.0*, Version 2.0, accessed 24 June 2015.  
<https://www.nehta.gov.au/implementation-resources/ehealth-foundations/EP-1805-2014/NEHTA-1716-2014>
- [NEHT2015q] National E-Health Transition Authority, To be published, *Pathology Report with Structured Clinical Content Information Requirements*, Version 1.0.
- [NEHT2015t] National E-Health Transition Authority, 10 April 2015, *Clinical Documents Common Conformance Profile*, Version 1.6, accessed 08 December 2015.  
<https://www.nehta.gov.au/implementation-resources/clinical-documents/EP-1818-2015/NEHTA-1850-2015>
- [NEHT2016g] National E-Health Transition Authority, To be published, *Pathology Report with Structured Clinical Content Structured Content Specification*, Version 1.0.
- [RFC2119] Network Working Group, 1997, *Key words for use in RFCs to Indicate Requirement Levels*, accessed 29 October 2015.  
<https://tools.ietf.org/html/rfc2119>
- [RFC3066] Network Working Group, 2001, *RFC3066 - Tags for the Identification of Languages*, accessed 13 April 2010.  
<http://www.ietf.org/rfc/rfc3066.txt>
- [RING2009] Ringholm, 2009, *CDA Examples*, accessed 15 March 2010.  
[http://www.ringholm.de/download/CDA\\_R2\\_examples.zip](http://www.ringholm.de/download/CDA_R2_examples.zip)
- [SA2006a] Standards Australia, 2006, *AS 4846 (2006) – Health Care Provider Identification*, accessed 17 July 2014.  
<http://infostore.saiglobal.com/store/Details.aspx?ProductID=318554>
- [SA2006b] Standards Australia, 2006, *AS 5017 (2006) – Health Care Client Identification*, accessed 17 July 2014.  
<http://infostore.saiglobal.com/store/Details.aspx?ProductID=320426>